

Evacuation condensats
Ø 22 ext.

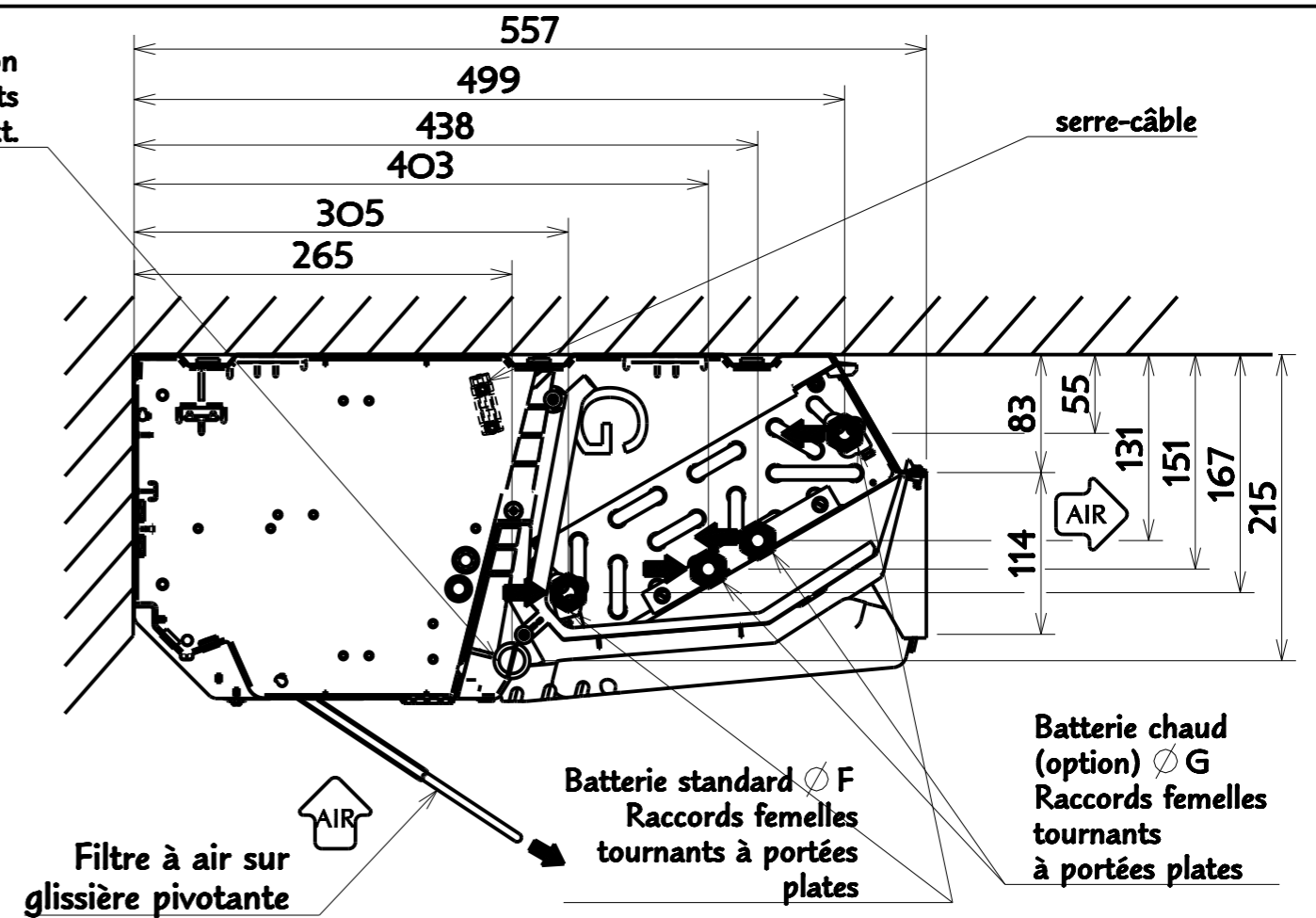

Raccordements hydrauliques représentés pour batteries 2T ou 4TX . Pour batteries 4TY , voir folio 5

Prises à droite = appareil symétrique

Boitier électrique

TAILLE	REF	A	B	C	D	E	F	Ø G	Ø H
T1	102A-102B-102C-102D	655	505	345	317	335	267	G 1/2	/
	104X							G 1/2	G 1/2
T2	202A-202B-202C-202D	815	665	505	397	415	347	G 1/2	/
	204X							G 1/2	G 1/2
T3	302A-302B-302C-302D	1015	865	705	497	515	447	G 1/2	/
	304X							G 1/2	G 1/2
T4	402A- 402C	1215	1065	905	597	615	647	G 1/2	/
	402B - 402D							G 3/4	/
	404X							G 1/2	G 1/2
T5	502A	1415	1265	1105	697	715	847	G 1/2	/
	502B - 502C - 502D							G 3/4	/
	504X							G 3/4	G 1/2
T6	602B - 602C - 602D	1615	1465	1305	797	815	1047	G 3/4	/
	604X							G 3/4	G 1/2

MODIFIE PAR : N. JIGUET DATE : 20-06-2017
 N° OMT : DATE : ...
 DESSINE PAR : MARMILLON DATE : 22-10-2010

MODIFICATION : MISE A JOUR DES PLENUMS Y DE T1 A T4
 PNEUMOBREM NCV/NCH MT1VD/41VD-SANS MANCH.
 PRISES A GAUCHE-RACCORDEMENTS OPPOSES

APPAREIL OU UNITE : MAJOR LINE

REFERENCE :
 CIAT ECHELLE 0.200 FOLIO 1/5 FORMAT A3 NUMERO DE PLAN 7285308 INDICE 01

CE DOCUMENT EST LA PROPRIETE DE CIAT, IL NE PEUT PAS ETRE UTILISE, REPRODUIT OU COMMUNIQUE SANS AUTORISATION ECRITE

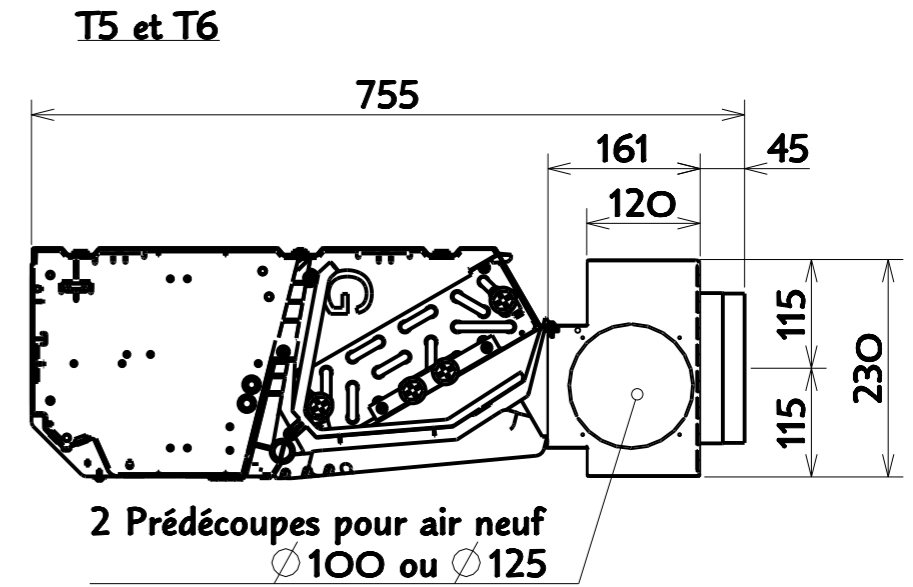
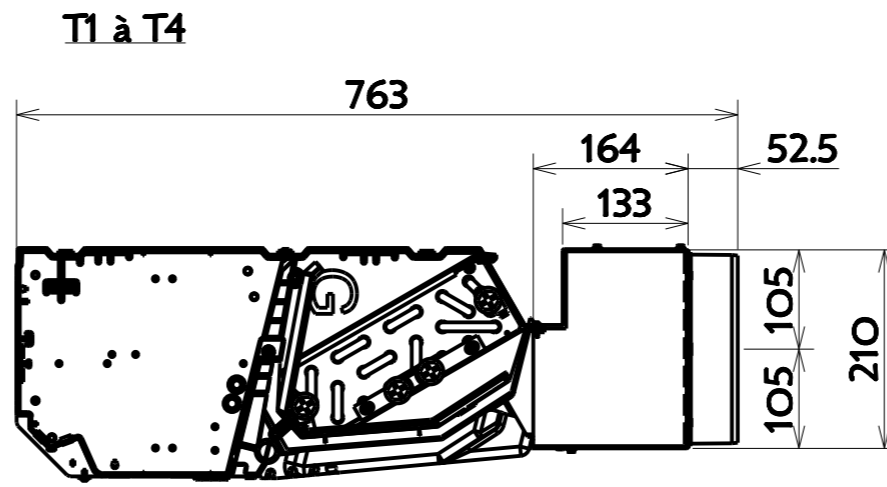
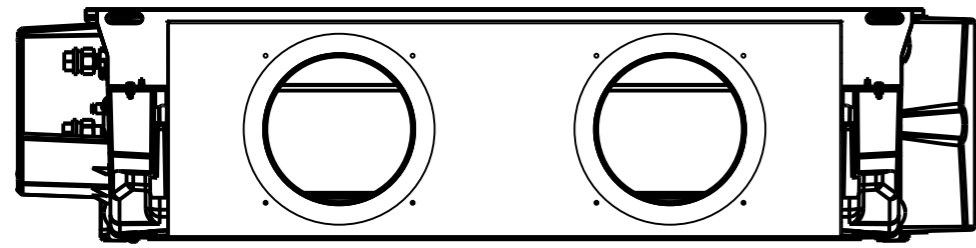

T6	7242996	1314	350	3
T5	7242995	1114	350	3
T4	7512288	914	300	3
T3	7512286	714	350	2
T2	7512284	514	/	1
T1	7512282	354	/	1
Modèle	Codes	A	B	N

Montage Y \varnothing 200

N viroles \varnothing 200

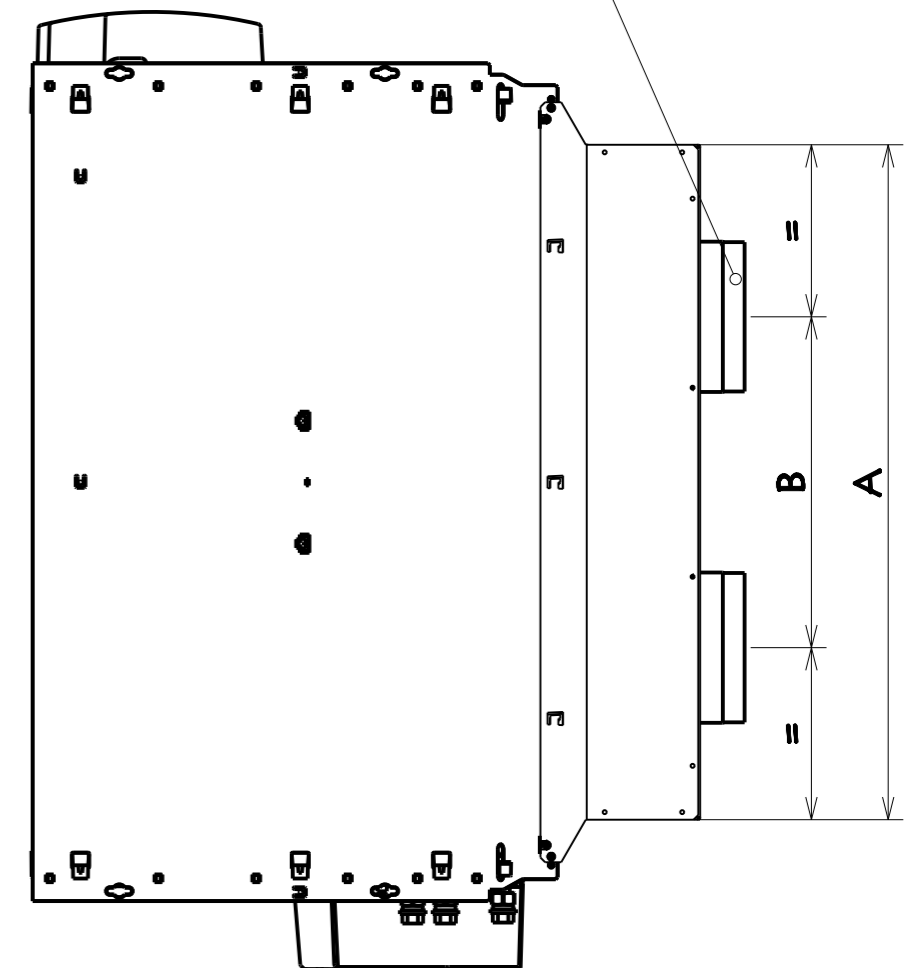
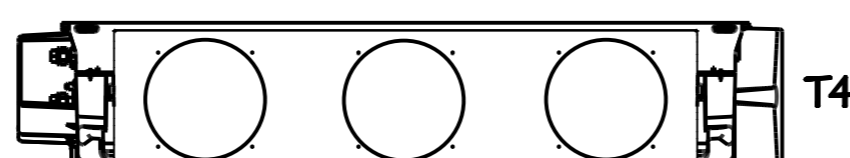
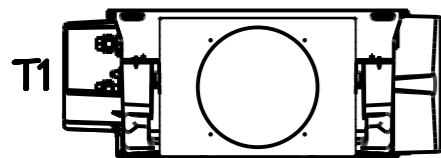
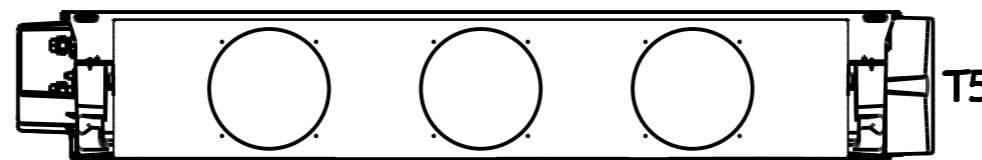
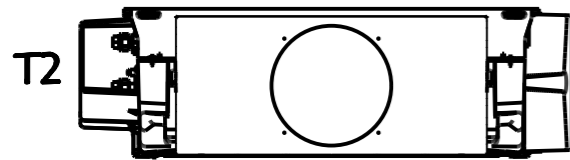
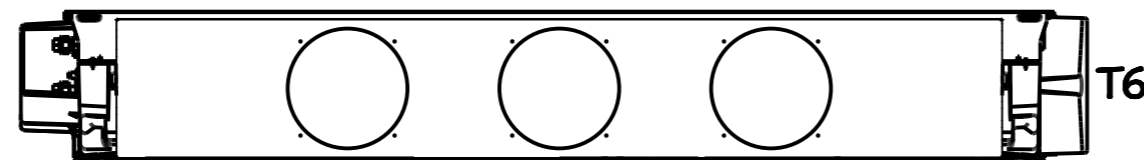
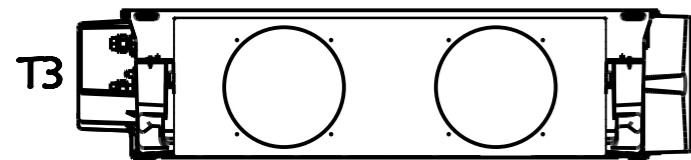

MODIFIE PAR : N. JIGUET DATE : 20-06-2017

MODIFICATION : MISE A JOUR DES PLENUMS Y DE T1 A T4

REFERENCE :

N° OMT :

DATE : ...

PRECOMBUSTION NCV/NCH MT1VD/41VD-SANS MANCH.
PRISES A GAUCHE-RACCORDEMENTS OPPOSES

APPAREIL OU UNITE :

MAJOR LINE

DESSINE PAR : MARMILLON

DATE : 20-10-2010



ECHELLE
0.125

FOLIO
2/5

FORMAT
A3

NUMERO DE PLAN
7285308

INDICE
01

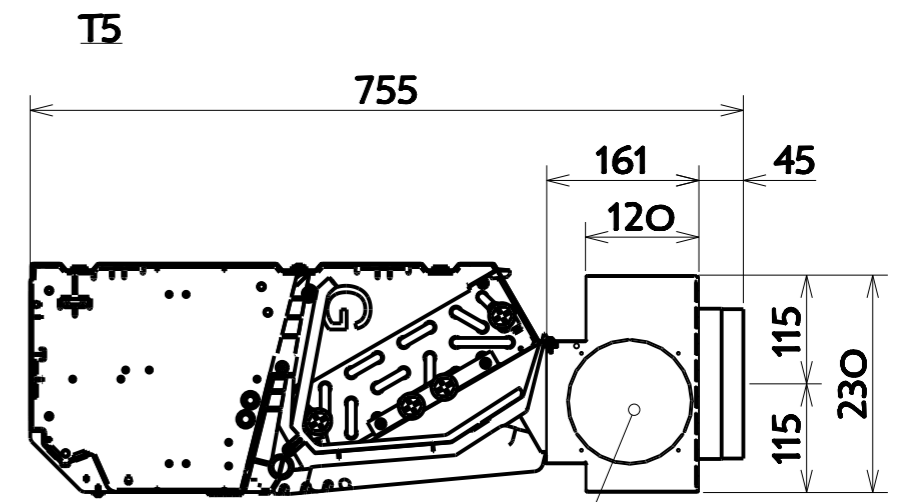
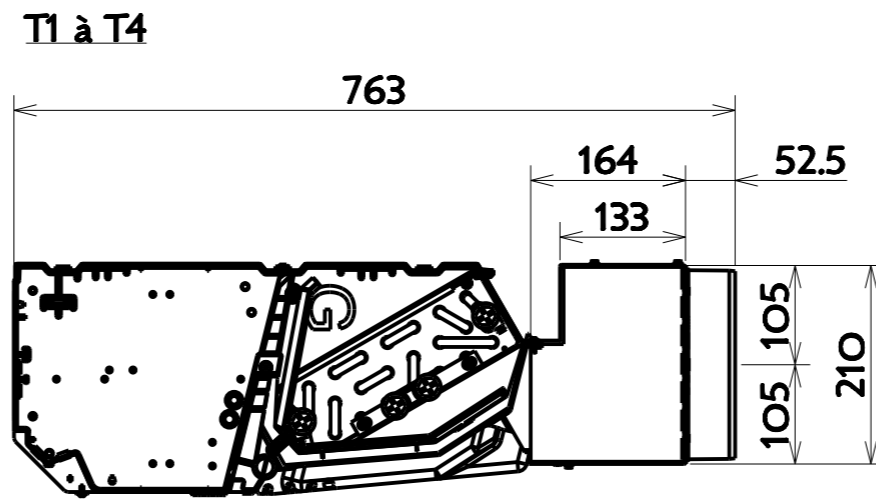
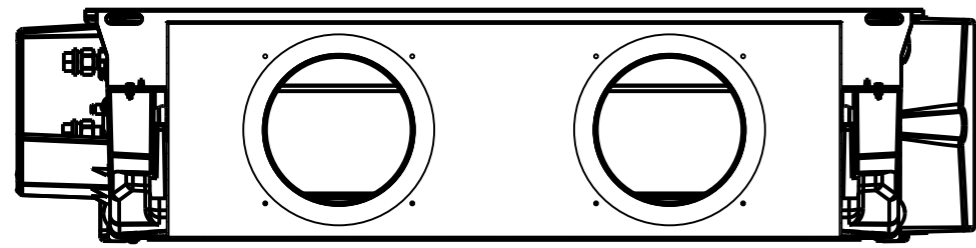

2 Prédécoupes pour air neuf
 $\varnothing 100$ ou $\varnothing 125$

T5	7243490	1114	350	3
T4	7512289	914	600	3
T3	7512287	714	350	2
T2	7512285	514	/	1
T1	7512283	354	/	1
Modèle	Codes	A	B	N

Montage Y $\varnothing 160$

N viroles $\varnothing 160$

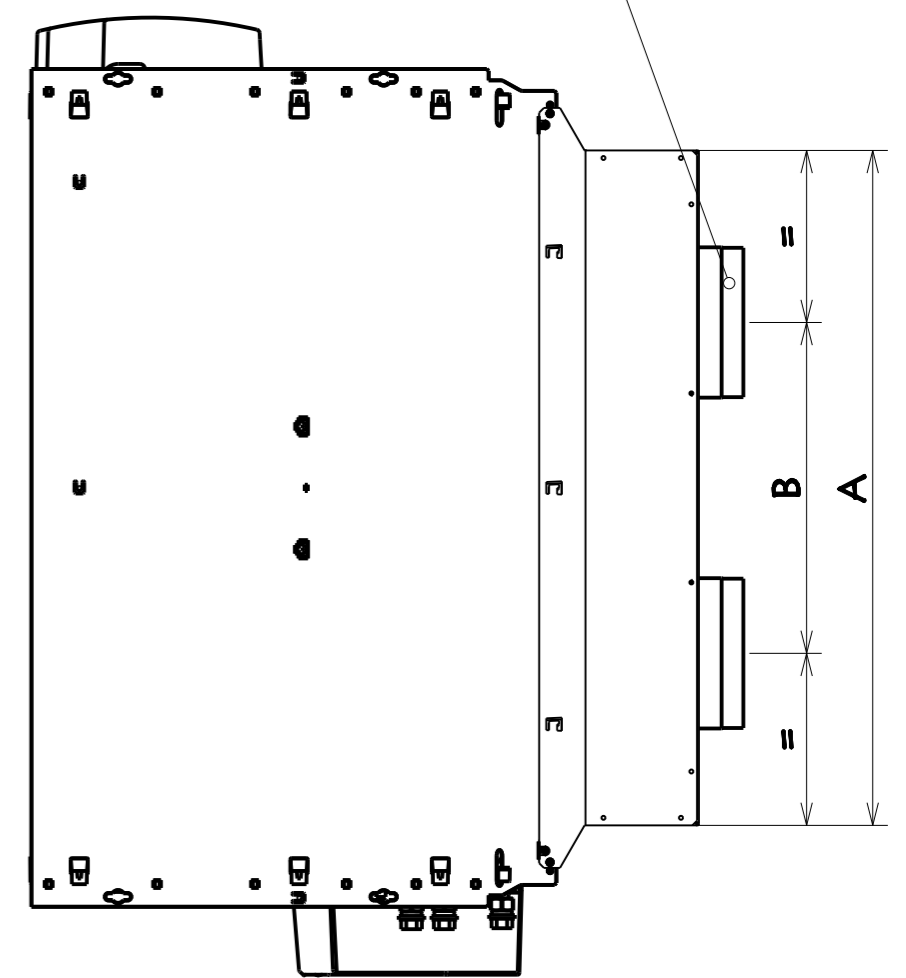
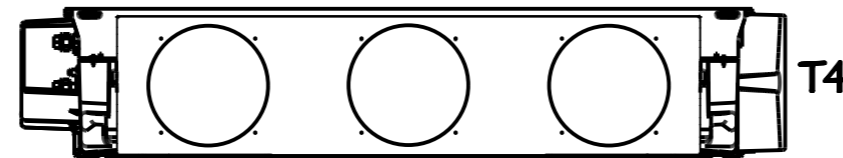
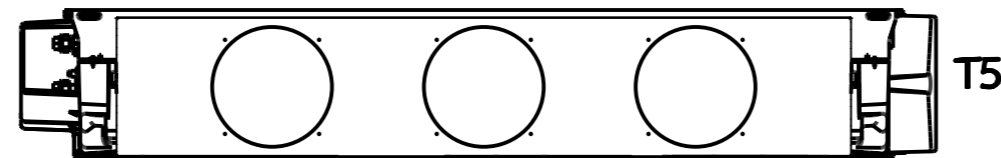
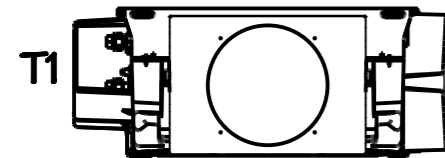
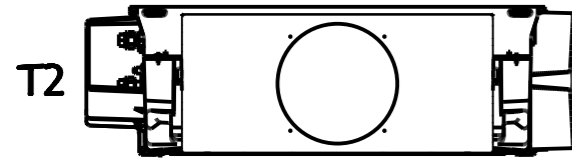
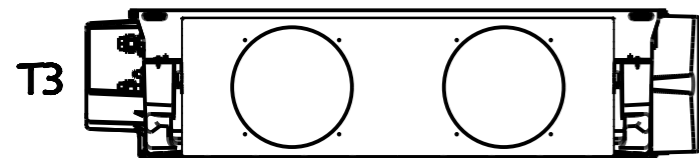

CE DOCUMENT EST LA PROPRIETE DE CIAT, IL NE PEUT PAS ETRE UTILISE, REPRODUIT OU COMMUNIQUE SANS AUTORISATION ECRITE

Kit de diffusion YK

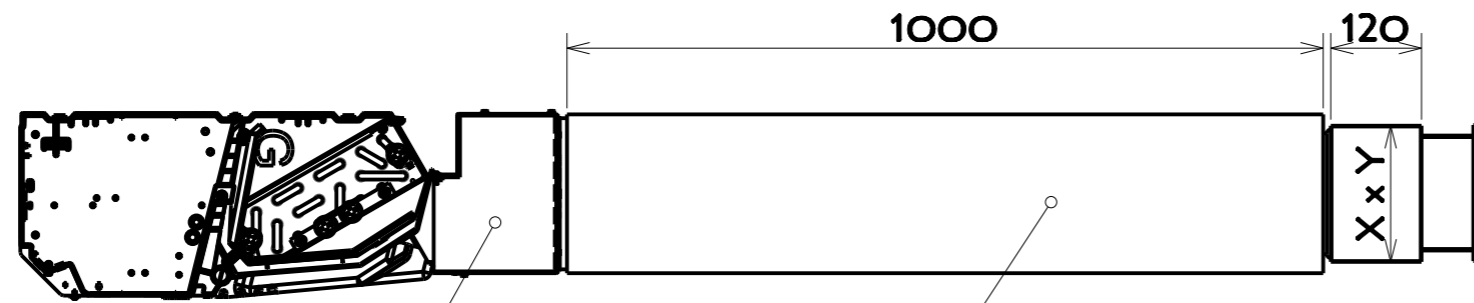

Plénum Y ϕ 160

Gaine souple isophonique ϕ 160

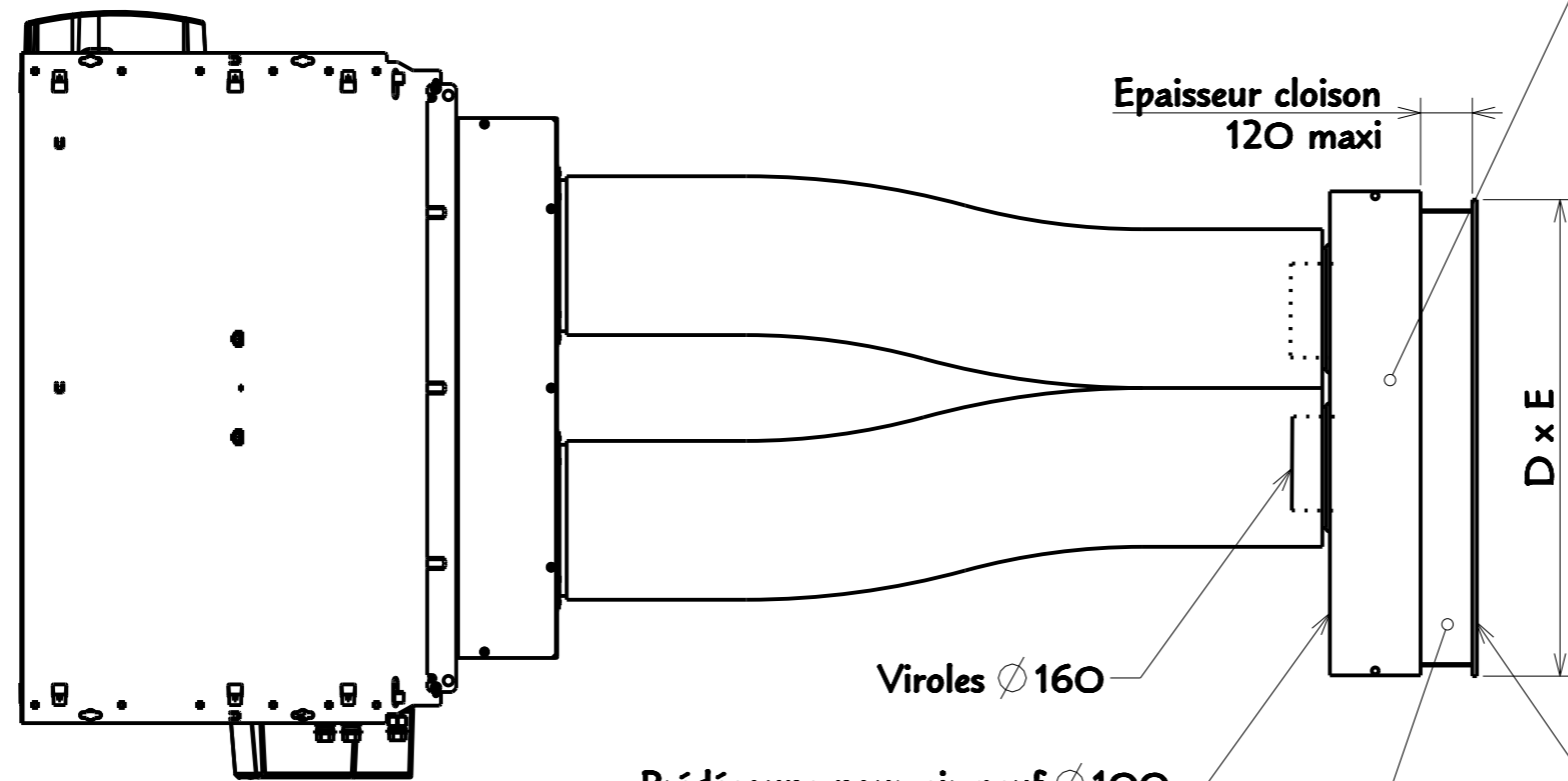

Epaisseur cloison 120 maxi

Réservation : H x L

MODELES	CODES	D x E	H x L	X x Y
T1	7057210	430x180	150X400	180X440
T2				
T3	7057218	630x180	150X600	180X640
T4	7057222	830x180	150X800	180X840
T5				
T6	/	/	/	/

Viroles ϕ 160

Prédécoupe pour air neuf ϕ 100

Manchette télescopique

Grille de diffusion double déflexion RAL 9010

MODIFIE PAR : N. JIGUET DATE : 20-06-2017

MODIFICATION : MISE A JOUR DES PLENUMS Y DE T1 A T4

REFERENCE : .

N° OMT : . DATE : ...

PRECOMBUSTION NCV/NCH MT1VD/41VD-SANS MANCH. APPAREIL OU UNITE : MAJOR LINE

MAJOR LINE

DESSINE PAR : MARMILLON DATE : 22-10-2010

PRISES A GAUCHE-RACCORDEMENTS OPPOSES



ECHELLE 0.100

FOLIO 4/5

FORMAT A3

NUMERO DE PLAN 7285308

INDICE 01

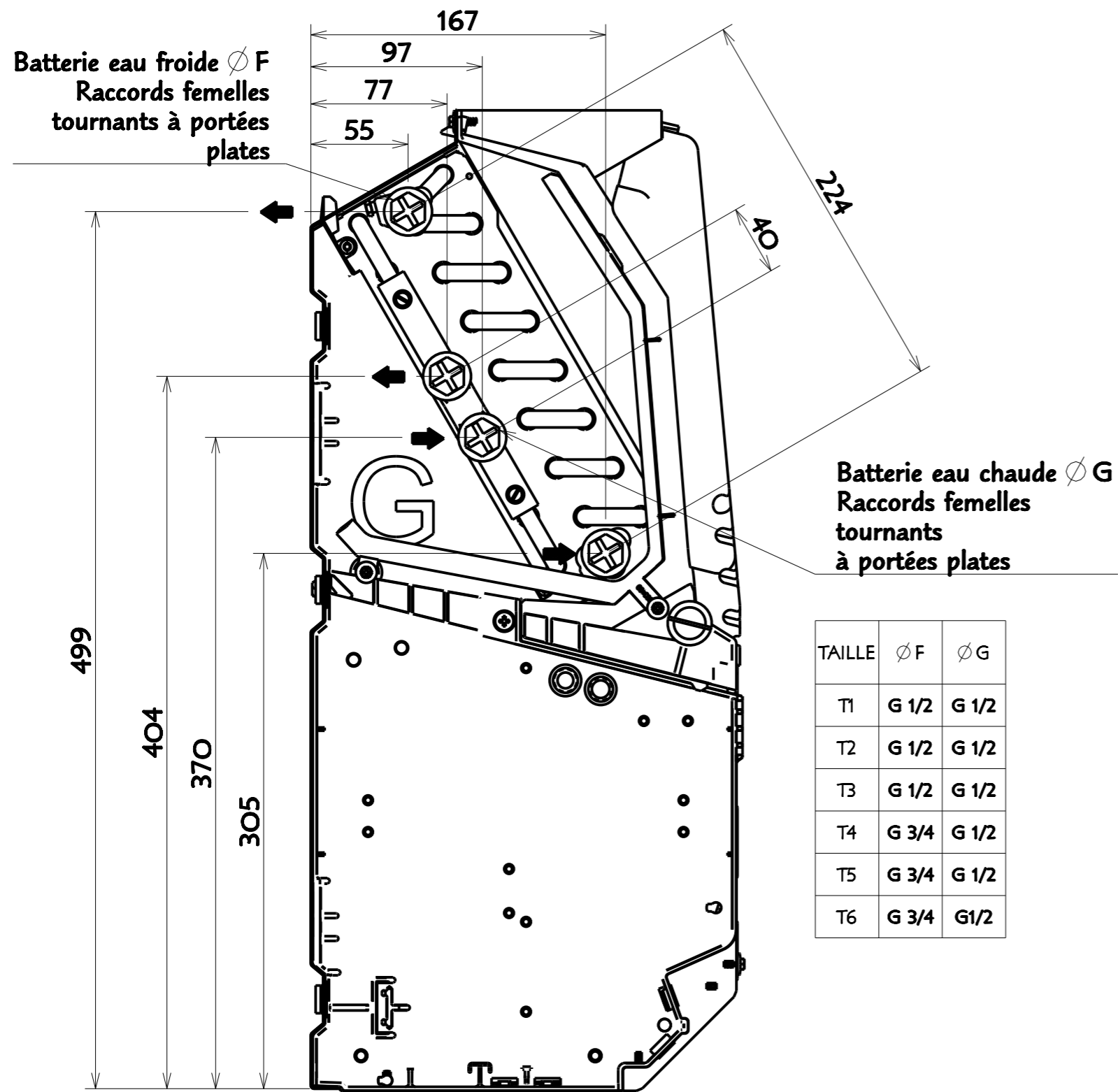

**BATTERIE 4T Y
(PRISES A GAUCHE)**

TAILLE	Ø F	Ø G
T1	G 1/2	G 1/2
T2	G 1/2	G 1/2
T3	G 1/2	G 1/2
T4	G 3/4	G 1/2
T5	G 3/4	G 1/2
T6	G 3/4	G 1/2

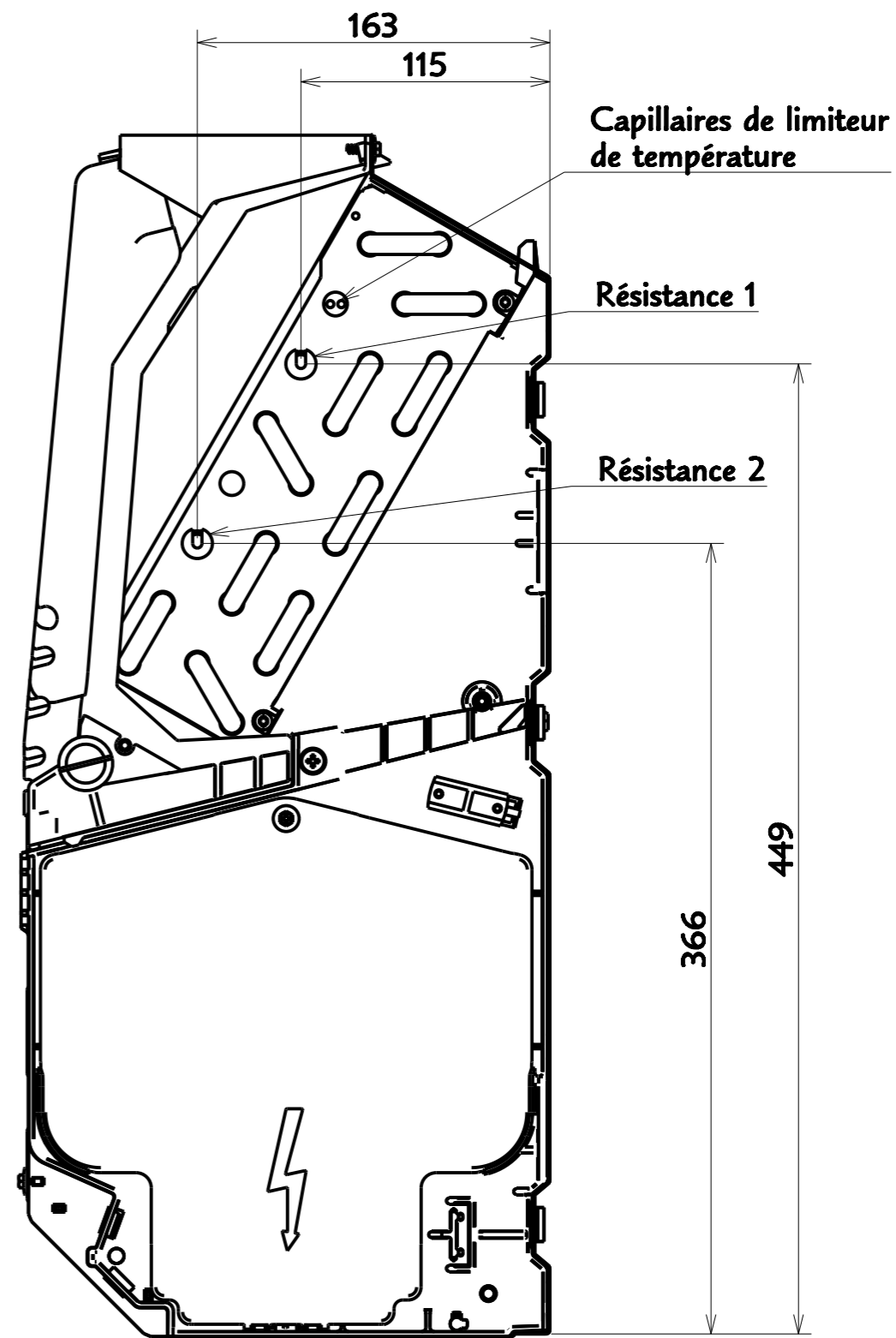

**POSITION DES
RESISTANCES
(PRISES A GAUCHE)**

MODIFIE PAR : N. JIGUET DATE : 20-06-2017

MODIFICATION : MISE A JOUR DES PLENUMS Y DE T1 A T4

REFERENCE : .

N° OMT : .

DATE : ...

PERFORATION NCV/NCH MT1VD/41VD-SANS MANCH.
PRISES A GAUCHE-RACCORDEMENTS OPPOSES

APPAREIL OU UNITE :

MAJOR LINE



ECHELLE
0.333

FOLIO
5/5

FORMAT
A3

NUMERO DE PLAN
7285308

INDICE
01