

EN7604935-00

01 - 2022

CLIMACIAT® CONCEPT

Instruction manual

Airtop
Airtech
Airclean



CONTENTS

1 - INTRODUCTION	4
1.1 - General safety instructions.....	4
2 - DELIVERY AND HANDLING	5
2.1 - Receiving and storing the unit.....	5
2.2 - Location.....	5
2.3 - Setup.....	6
3 - INSTALLATION	7
3.1 - Special recommendations.....	7
3.2 - Assembly - Fitting.....	7
3.3 - Filtration.....	12
3.4 - Water and direct expansion coil	12
3.5 - Electric heaters.....	14
3.6 - Control system	15
3.7 - Fan motor assembly.....	15
4 - SYSTEM START-UP	17
4.1 - Connecting the electric motor.....	17
4.2 - Blade damper.....	18
4.3 - Electric heater	18
4.4 - Water humidifier	18
5 - MAINTENANCE	19
5.1 - Casing	19
5.2 - Dampers.....	19
5.3 - Air filters.....	19
5.4 - Humidifiers	20
5.5 - Fan motor assembly.....	21
5.6 - Sound attenuator.....	21
5.7 - Heat recovery units	21
5.8 - Preventive maintenance.....	22
5.9 - Cleaning the units.....	22
6 - WARRANTIES	23
6.1 - Duration of warranty on coatings applied to outdoor air handling units	23
6.2 - Duration of the air handling unit warranty.....	23
7 - SPECIAL INFORMATION FOR ATEX AREAS	24
7.1 - General information.....	24
7.2 - Marking.....	24
7.3 - System start-up, maintenance.....	24
7.4 - Using tools in an explosive atmosphere.....	25
8 - MEANING OF THE PICTOGRAMS	26
9 - REGULATIONS	27

1 - INTRODUCTION

This manual must be read before placing, installing or servicing the air handling unit.

Failure to follow the instructions in this manual could damage the air handling unit and will void its warranty.

CLIMACIAT® air handling units are intended solely for the purpose of handling air. No other uses (storage, etc.) are allowed. They should never be used for any other purpose (storage, support, etc.).

1.1 - General safety instructions

The following must be performed before any work on the air handling unit :

- The power must be switched off (proximity switch)
- The fan must be stopped (WARNING: it may take several minutes to stop completely)
- Electrical equipment must be switched off (electric heater, humidifier, purifiers, etc.)
- Work must be carried out by an accredited technician.
- PPE (Personal Protective Equipment) must be used for all work.

2 - DELIVERY AND HANDLING

2.1 - Receiving and storing the unit

The condition of the unit must be inspected upon receiving it.

In case of damage, **specify this in full on the delivery note**, indicating the type of problem (upper panel dented, coil damaged, etc.).

Confirm your observations concerning the damage with the carrier by registered letter within 48 hours of delivery and send a copy to your CIAT representative.

Terms such as "pending unwrapping" and "unit damaged but packaging in good condition" are not admissible by insurance companies.

For all other problems, please contact your CIAT representative for further information.

The unit must be stored in its packing and sheltered from weather.

To facilitate the assembly of multisplit units, their components must be kept in the relevant groups. Refer to the dimensional drawings and identification labels placed on each section (see below).

2.2 - Location

The air handling units are relatively large. Extra attention is required when choosing where to place them.

As is generally the case with boilers and refrigeration units, we recommend installing the air handling units in machine rooms that are sufficiently insulated from adjoining rooms.

It is also important to leave sufficient space around the units to allow access to the various components: bearings, belts, motors, filters, coils, etc. Refer to the diagram below to ensure trouble-free maintenance.

A clearance of 600 mm is recommended for assembling the sections

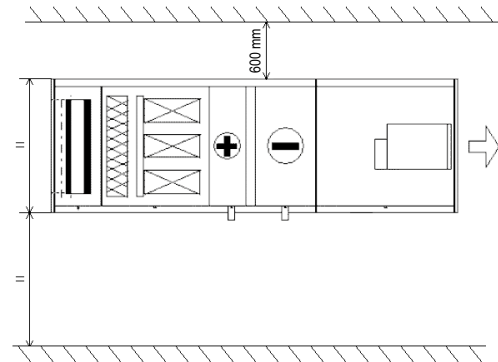

①	N° DE COMMANDE 07017646		②	BLOC B2	
③	OF01116857				
④	DESIGNATION: TECH 75 B2 LI400 IH INT 40				
⑤	CLIENT: IMHOFF S A		⑥		CONTRÔLE
⑦	REFERENCE: NEANT				
⑧	MASSE	ANNEE DE FABRICATION 2007		⑨	
⑩	CENTRE DE GRAVITE: X= Y=				

- ① Order number. Use in all correspondence.
- ② Section number
A1, A2, ...A9: multi-section unit.
A second unit may bear the markings B1, B2, ...B9.
The numbers 1, 2 and 3 do not necessarily indicate the order of assembly (refer to the dimensional drawing).
A9, B9...: markings for all accessories: assembly, roofs, canopies, gaskets, fastenings, etc. of the corresponding unit.
- ③ CIAT internal production order.
- ④ CIAT internal coding.
- ⑤ Your name or company.
- ⑥ Internal pre-shipping check.
- ⑦ Your reference (if applicable).
- ⑧ Weight of corresponding block.
- ⑨ Block year of manufacture.
- ⑩ Centre of gravity to facilitate positioning of the lifting beam.

2 - DELIVERY AND HANDLING

2.3 - Setup

Handle the boxes carefully. Lift them using a lifting beam suitable for the size of the unit (refer to the diagrams below), two steel tubes (minimum diameter 1": 33.7 mm external; maximum 1¼": 42.7 mm external) and straps, as per the handling instructions (minimum angle of 60°).



Make sure that the spreader beam is sufficiently large so that the straps do not press against the unit and the steel tubes are immobilised while moving the unit.

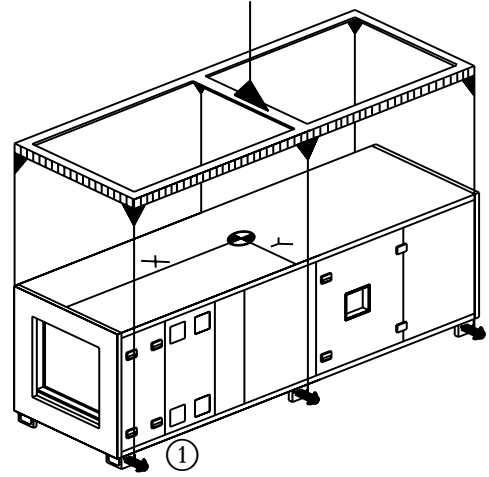
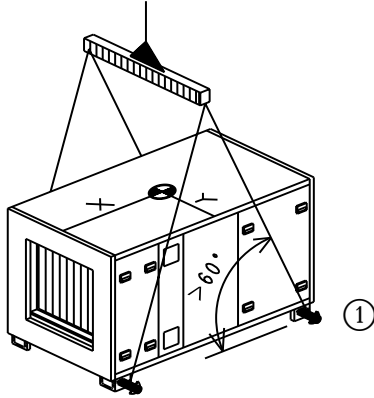

① Limiting sideways movement

If using a spreader beam is not possible, the unit may be lifted using a forklift truck provided care is taken to avoid denting the bottom panel (use sufficiently long forks).

Follow the applicable handling rules.

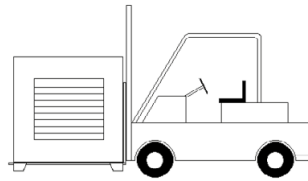

3 - INSTALLATION

The equipment must be installed in accordance with the legislation applicable to the installation site.

3.1 - Special recommendations

- Connections must not place mechanical stresses on the unit.
- Air and hydraulic pipes must be secured using supports.
- Keep all inspection doors closed while the unit is operating.
- A safety device in case of insufficient air flow must be integrated in the fan control.
- For outdoor installations, units must be installed in accordance with best industry practice to withstand the weather conditions in the installation location, (risk of snow: height of installation from the ground, risk of wind: adapted mountings, etc.).

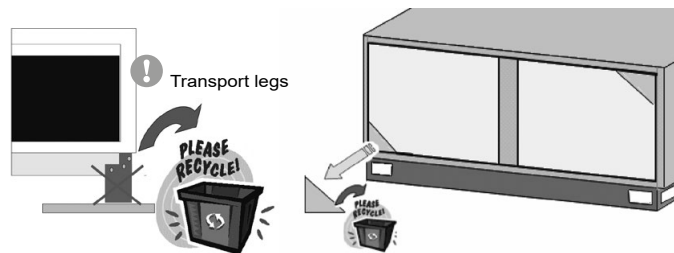
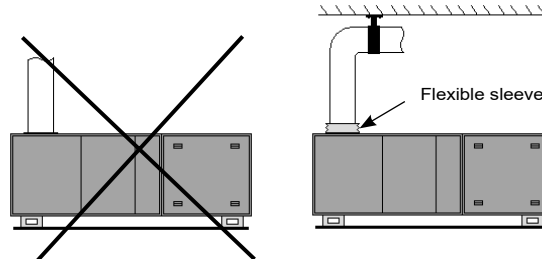

! Make sure to ground all electric components.

NOTE: For large units (plate/wheel recovery units, mixing units, etc.), the transport brackets located at the corners must be removed upon delivery.

3.2 - Assembly - Fitting

The damper sleeve and ducts are connected to the AHU using 5.53 sheet metal screws.

! The box(es) making up the air handling unit must be installed on a flat, sturdy surface. To ensure a tight seal between joined sections, they must be shimmed and levelled to compensate for any unevenness of the mounting surface.

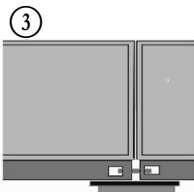
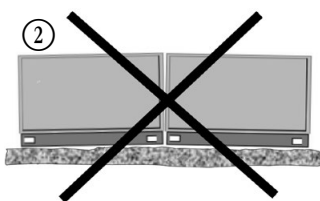
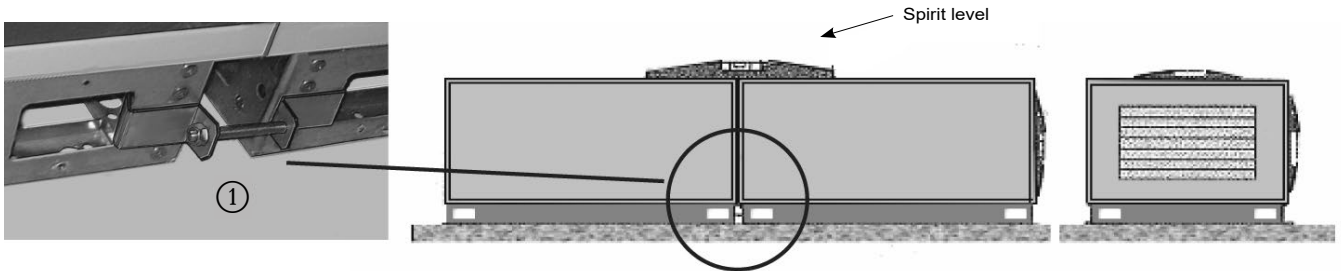

- ① Connection components
- ② Use securing devices at the ends
- ③ Fit anti-vibration mounts:
Insulating foam block + intermediate plates between frames
- ④ Always place the unit(s) on a counterframe when adding anti-vibration mounts (frame and mounts to be provided by customer)
- ⑤ Intermediate mounts prohibited (deformation of the lower block)

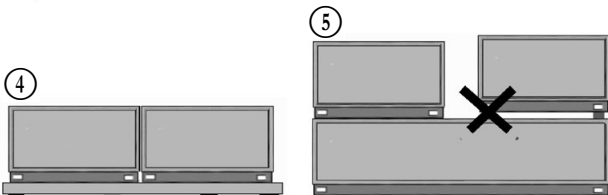

3 - INSTALLATION

■ Assembling the two blocks

- Check the flatness and levelness of the mounting surface.
- Fit the gasket on the sealing face between the blocks (**fig. A**).
- Using the appropriate handling equipment, place the two sections to be joined as close to each other as possible.
- The blocks are assembled on the same level by connecting the frames or the feet using connection components (**fig. B**). Secure outdoor units using a TH 8 x 70 screw, washers and nuts (**fig. C**). A plate provides a seal between the two casings (fitted with mastic) (**see fig. D in the outdoor assembly section**)

If assembling the sections vertically, the top section must not be mechanically fastened to the bottom section. Its weight will keep it in place.

! Before tightening the brackets, seal the sections with a gasket or caulking.

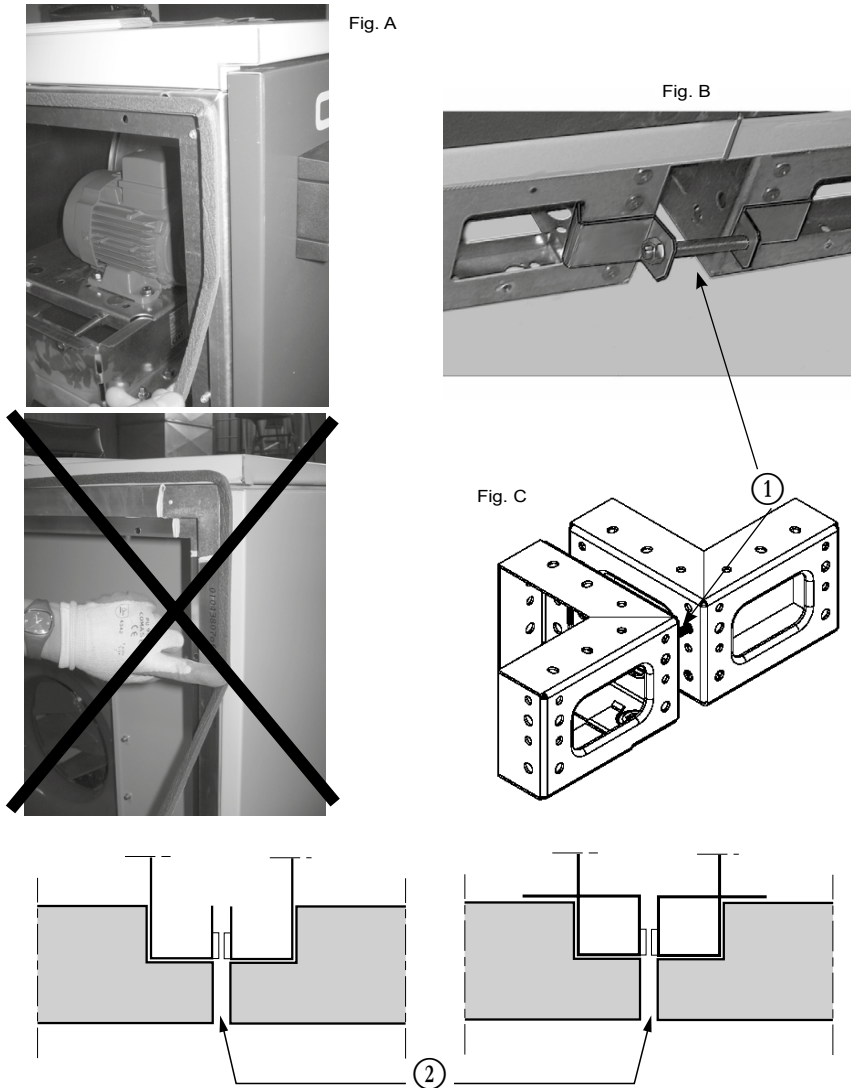

- ① Attachment screw
- ② Gasket or mastic

Fastening clamps are supplied for a tighter fit between sections on size 150 and higher air handling units. They may be placed on the sides or tops of each section.

- Trace the mounting holes (centre distance: 38 mm) and drill a diameter 4 hole.
- Attach the clamps with the screws supplied.
- Join and tighten the clamps together with the two 6 x 60 mm screws, washers and nuts.

Comment: these clamps cannot be used on access panels.

! Do not use the fastening clamps to compensate for misaligned sections.

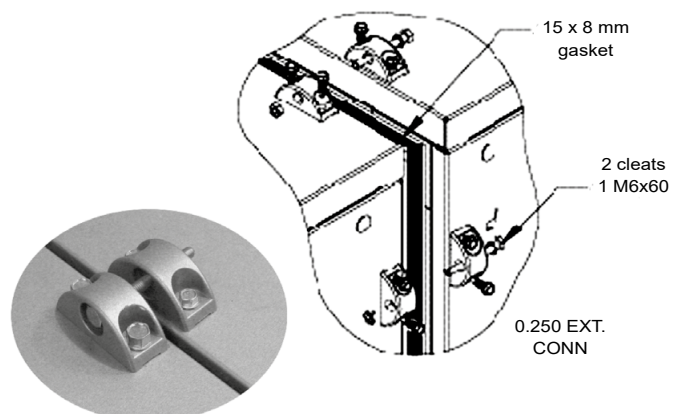

3 - INSTALLATION

Where possible (door nearby, footprint, etc.) the clamps may be tightened on the inside with TH 6 x 60 bolts.

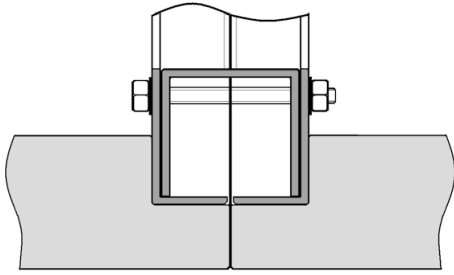

Sizes 25 to 75

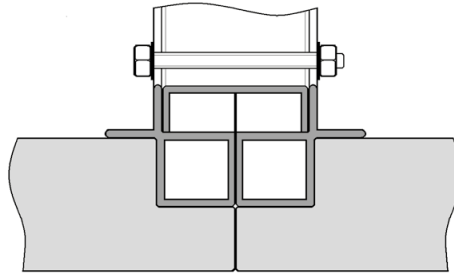

Sizes 100 to 600

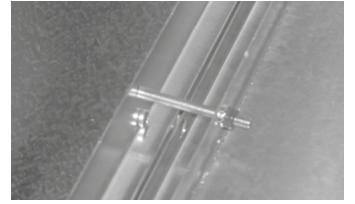

An optional decorative trim is available for bottom AIR CLEAN units only.

■ Dual-flow assembly with stacked casings (A) and (B)

The unit can be assembled in one of two ways depending on its size:

25 to 75 units: affix the feet of block B to the intermediate panel (2) using two TH 6x20 screws. Holes are provided for this purpose.

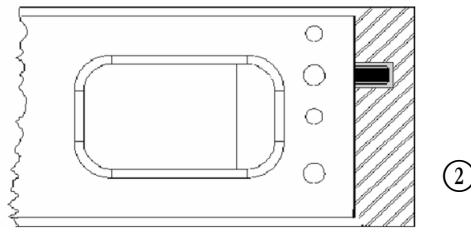

100 to 600 units: affix the brackets to the feet of block B, and the mounts to the panel using the screws provided. Assemble using two screws (6x120), washers and nuts.

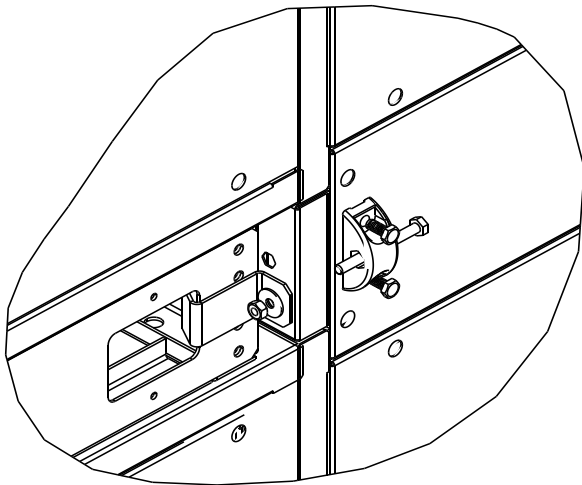

Block B

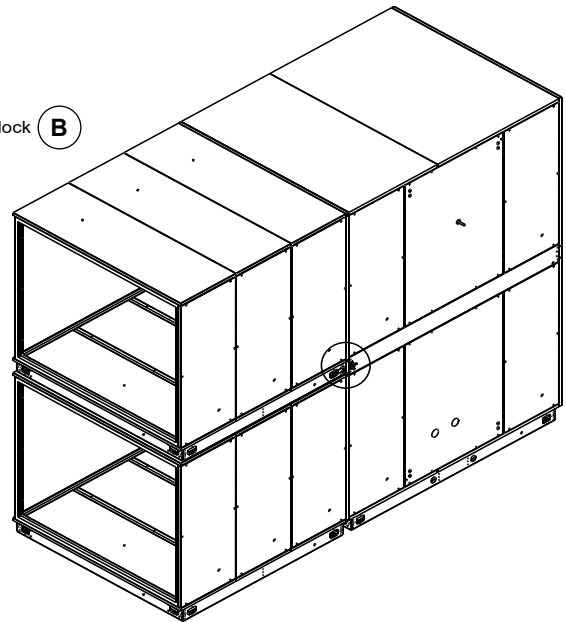

3 - INSTALLATION

■ Assembling stacked casings (A and B) with a thermal wheel recuperator (C)

Fasten the feet on section B to the middle panel (1) with two TH 6 x 20 screws in the holes provided.

Holes are provided for this purpose.

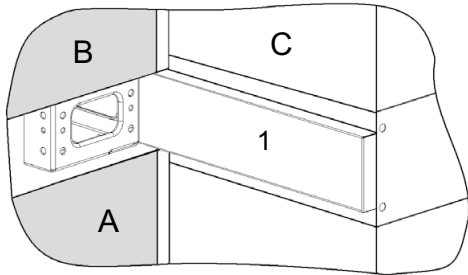

■ Assembling adjacent casings

The first air stream (fig.1) is installed in the same way as on horizontal air handling units. (see block interconnection).

The second air stream is connected to the outside (Fig. 2) in the same ways as the sections. The insides (inaccessible) are connected from inside when possible and/or using the outer lugs on the top of the box (impossible on outdoor handling units on account of the roof).

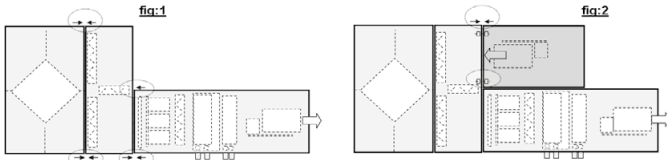

■ Ceiling installation

Suspended units must be placed on a metal section suspended from the building structure. Each pair of feet must rest on a metal section. Each pair of feet must rest on a metal section.

These sections are to be provided by the fitter and must be cut to suit the layout of the room and be sufficiently rigid. The sections should not block access to the drawers and doors on the unit. Leave space for platform access on the connections side.

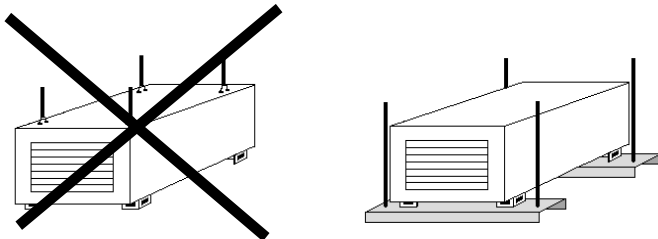

■ Outdoor installation

Air handling units installed outdoors must be protected by a roof (Fig. 1) or overhang (Fig. 2). These components are generally delivered in kits and adapted to each configuration.

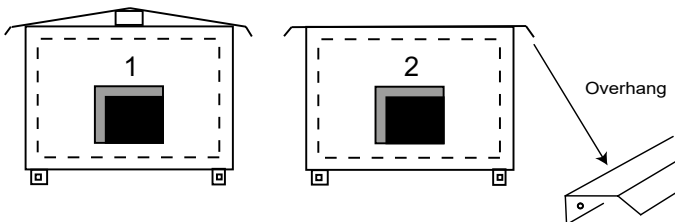

■ Fitting the roofs

Affix the gasket (1) along the length of the unit (50 x 20 foam gasket).

Fit the roof panels along the entire length of the unit, placing a foam seal (supplied by CIAT) between each panel (2).

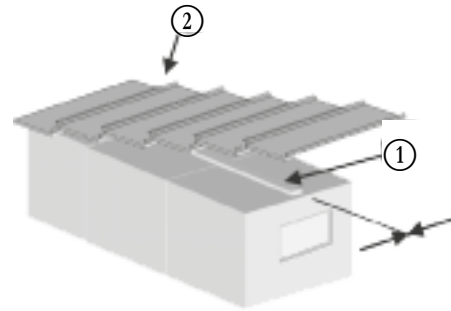

Assemble the panels as per the roof diagram and drawing supplied with the unit

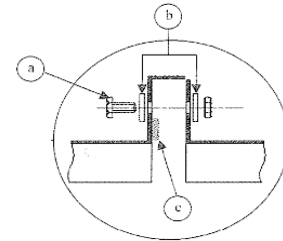

- a M6 x 16 screw
- b Sealing washer
- c Gasket

Assemble the panels to side A of the unit as shown in the drawing opposite:

Then assemble the panels to side B, pressing on the roof to create the curve. Fasten the panels to the box.

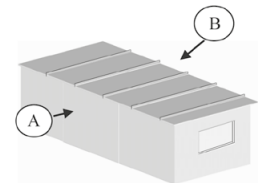
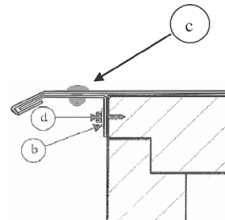

- a Sealing washer
- b Self-tapping screw (supplied)
- c Sealing rivet

In addition the rules mentioned on the previous pages, special care must be taken with the hydraulic system (do not forget the risk of freezing temperatures).

If the unit is fitted with an external air intake, we recommend protecting it from prevailing winds and any exhausted air or gases (chimneys, roof extractors, etc.). Follow the requirements in standard EN 13779.

If the unit is installed on a deck or patio with a top intake and/or discharge, the unit must be placed above the roof or deck/patio. Locations where ducts and pipes extend through the roof or deck/patio must be completely watertight.

3 - INSTALLATION

■ Counter frame sealing for outdoor installation

Caulk during assembly

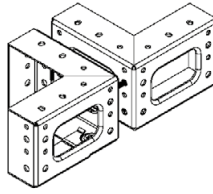

■ Fitting the canopies

Assemble the top panel (1) to its two side panels (2) and (3) with 6 mm screws, washers and nuts or rivets.

Affix the sealing gasket (4) around the edge of the canopy and apply mastic if necessary.

Fit the screen and the canopy and affix the assembly to the unit using diameter 5.53 sheet metal screws and washers

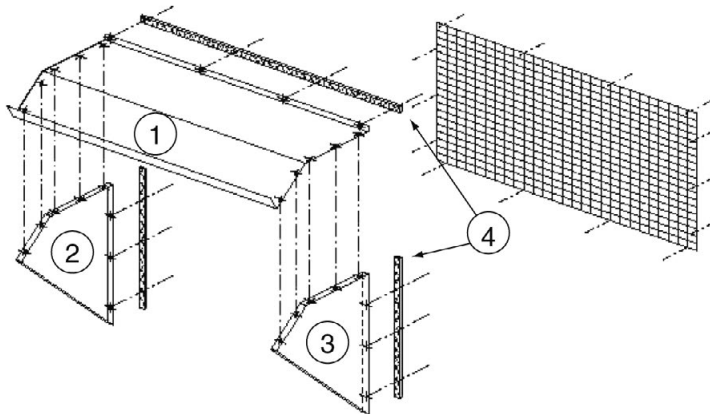
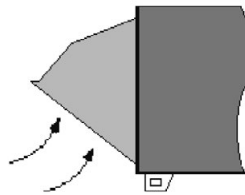

The canopy is delivered in a kit. Drill the necessary holes in the box during assembly.

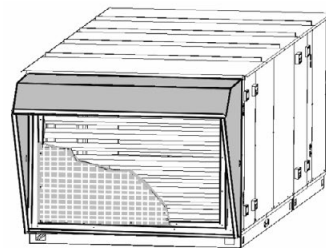
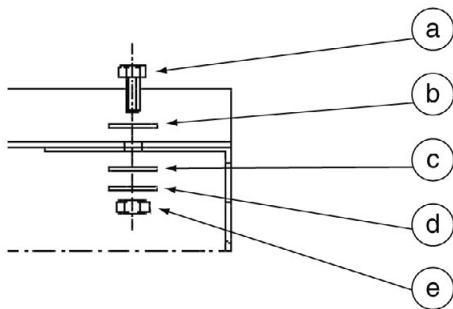

- a Sealing rivet or M6 x 16 screw
- b M6 sealing washer
- c M6 plain washer
- d M6 external tooth lock washer
- e M6 nut

3 - INSTALLATION

■ Mounting brackets

To guarantee a greater clearance height, fit raised feet under the standard frame feet.

Extension leg (100 mm/200mm/300mm)

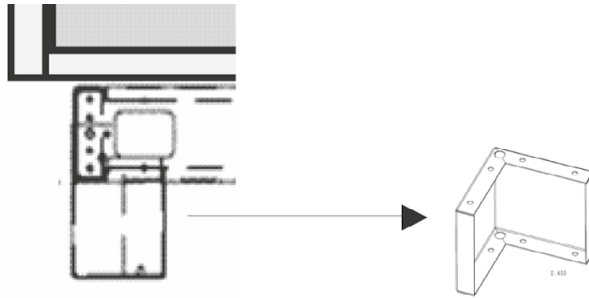

Adjustable leg (option).

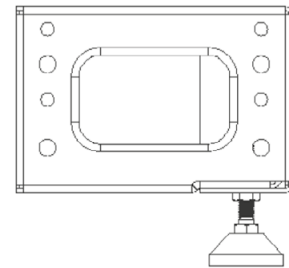

3.3 - Filtration

- G2 filters: the cell may be inserted in any direction regardless of the direction of air flow,
- G4 filters: the mesh holding the medium in place must face the discharge air side,
- HPS bag filters HPS (F6, F7, F8), high-efficiency and HPR filters: the cells on the frame side must face the incoming air,
- HEPA filters (H10, H14): refer to the instructions supplied with filters for information on fitting and maintaining them,
- Carbon filters: refer to the instructions supplied with the filters.

G2 and G4 filters are supplied fitted on the unit. Other filters are supplied in their packing.

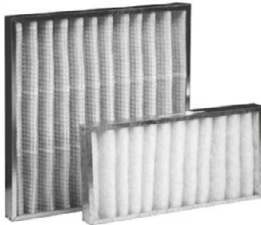

①



②

②



③

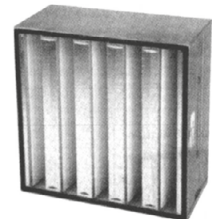

④

- ① G4 filter
- ② HPS filter
- ③ HPR or carbon filter
- ④ HEPA filter

3.4 - Water and direct expansion coil

Do not remove the protective caps until you are ready to connect the coils.



■ Coil with water supply

! Always use two spanners when connecting or tightening the hydraulic couplings to avoid twisting the pipes and applying stress on the welds. Check the tightness of the connections before installing heat insulation or filling the system with water.

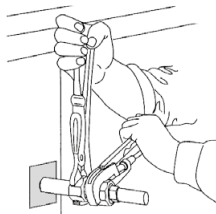

If flanges are used, provide enough clearance for the frost protection sensor drawer or the droplet separator drawer. The flanges should be offset.

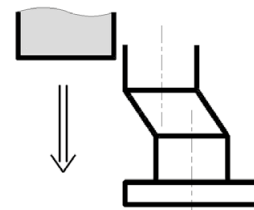

■ Supplying the coils

! water + glycol = risk of burns and toxic if ingested

Refer to your dimensional drawing for the diameters of the connections and their positions.

Check the connections for leaks after 24 hours.

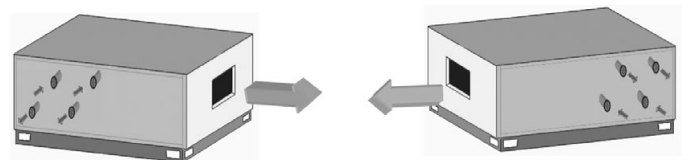

3 - INSTALLATION

■ Coil maintenance

- Clean air is essential to the efficiency of the unit. Use an air filter.
- The coil may be cleaned with compressed air. However, make sure particles are not blown into any other sections of the unit.
- If a glycol/water mix is used in water-cooled heat exchangers, check the glycol/water ratio.
- If the coil is extremely dirty, disassemble it and clean it with a high-pressure washer. Keep the lance perpendicular to the coil surface.

Take the necessary steps to protect the coil from the risk of freezing temperatures.

■ Heating coil

Check the operation of the frost protection thermostat (option) at the start of each winter.

If the outlet temperature on the frost protection coil is below 15°C, use a constant-volume control valve to prevent the frost protection alarm being triggered and frost forming on the coil.



■ Cooling coil

Clean and replace the cells on the droplet separators as often as necessary. Prime the siphon at commissioning or each time the unit is stopped for extended periods. Keep the condensate pan and drain clean.

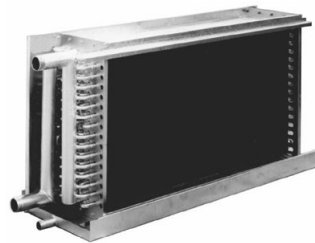

■ Siphon (recommendations)

Install a drain and a bleed valve on the supply pipes in accordance with accepted industry practices.

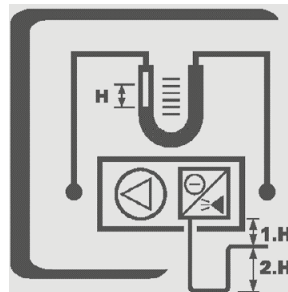

Install a siphon and a vacuum breaker to discharge condensate from the cooling coils. Their height should be equal to twice the negative pressure of the unit.

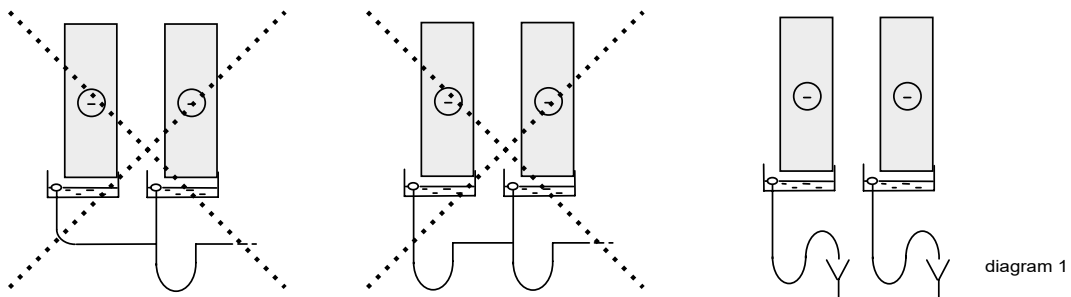

Handling units requiring more than one siphon:

Install siphons and vacuum breakers as shown in diagram 1.

3 - INSTALLATION

■ Direct expansion coil

Installation must be performed by qualified personnel.

For coils containing "SPLIT SYSTEM" refrigerant, the unit must not be stored near to a source of heat or in direct sunlight (increase in refrigerant pressure).

■ Droplet eliminator

They are placed downstream of the cooling coil. Clean them once a year with suitable products to remove any deposits. Specially designed products are available for this operation.

3.5 - Electric heaters

Electrical connection and control with the fan motor assembly:

Always follow general safety instructions and especially current standards (e.g. NFC 15-100 on overcurrent and overvoltage protection) when making electrical connections.

Always install an air flow pressure switch (control lot) and program a fan delay time of several minutes.

Connect the electric heater with high-temperature wires. Take into account the temperature inside the electric heater when selecting these wires.

Example: for a 2.5 diameter, 50 m cable (4 conductors), the following are available:

- 80°C high temperature cable: Max current: 45 A
- 120°C high temperature cable: Max current: 27 A

Connect these wires to the designated terminals and the terminals on the manual and automatic reset thermostats (depending on unit) inside the box.



The stages (power-connection terminals) are identified with labels of the same colour.

Power		
1 Ph	2 Ph	3 Ph

If there are three stages, there will be three sets of these labels.

The connections must be made as per the schematic diagram (example for connection of two heaters)

■ example:

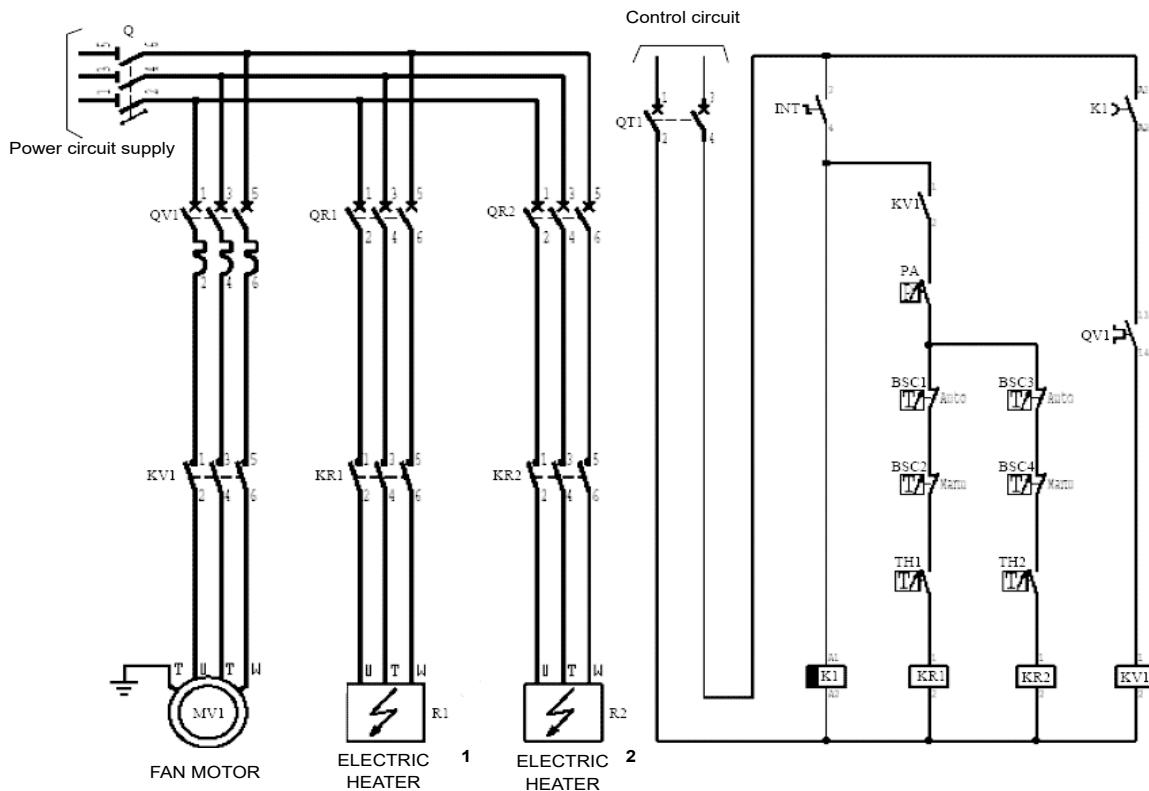

- | | | | | | |
|-----|--|-----|---------------------------------|------|---|
| Q | Main disconnect switch | QR2 | Electric heater thermal cut-out | Bsc1 | Electric heater safety thermostat automatic reset |
| Qv1 | Fan motor thermal-magnetic circuit breaker | Kr2 | Electric heater switch | Bsc2 | Electric heater safety thermostat manual reset |
| Kv1 | Fan motor switch | R2 | Electric heater | Bsc3 | Electric heater safety thermostat automatic reset |
| Mv1 | Fan motor | Qt1 | Remote control thermal cut-out | Bsc4 | Electric heater safety thermostat manual reset |
| Qr1 | Electric heater thermal cut-out | Int | On/off switch | Th1 | Room thermostat |
| Kr1 | Electric heater switch | K1 | Time-delay relay | Th2 | Room thermostat |
| R1 | Electric heater | Pa | Flow rate controller | | |

NB: Do not earth the electric heater (class 2 insulation). Instead, make a connection to the casing as close as possible to the heater.

3 - INSTALLATION

Retighten the connections after 48 hours of operation.

A suitable air flow rate controller (pressure switch, switch indicator, etc.) must be placed in the circuit to shut off power to the heaters should an air flow fault occur.

CIAT shall not be liable if this requirement is not followed.



Never operate the coil with the fan off.

For the variable-speed motors, the power dissipated by the coil must be proportional to the motor rotation speed and adjusted gradually. For a two-speed motor, the control system is configured so that the reduction in the air flow results in a proportional reduction in the heater power.

For example: 1500 / 750 rpm, coil capacity of 30 kW.

At low speed, the power dissipated by the heater must be reduced by 50% and not exceed 15 kW.



A number of factors can cause general overheating of the electrical elements, which can lead to the thermostats being triggered:

Examples:

- Turning on the unit without the fan,
- Filter fouling,
- Reversed fan rotation,
- Faulty operation of the air dampers,
- Insufficient voltage to the fan motor assembly belt.

3.6 - Control system

If the air intake is fitted with a motorised damper, the fan should not operate unless the opening limit switch is tripped.

If a two-speed motor is used, the shift from high to low speed should be timed to avoid a braking effect.

3.7 - Fan motor assembly

The spring-mounted fan motor assemblies (AIRTECH, AIRCLEAN ranges) are locked in place during shipment by three fasteners placed on either side of the support frame.

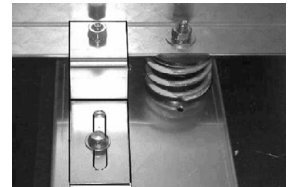

Remove the shims after installing the unit.

The direction of rotation must match that indicated on the fan.

In most cases the drive is fitted before leaving the factory. All that needs to be done is to retension the belts after 24 hours of operation. The tension depends on the belt type, the power to be transmitted and the rotation speed.



Overtensioning the belts will result in accelerated wear of the bearings. Undertensioning the belts will cause them to slip and wear down.

Place two strips of opaque adhesive tape exactly 250 mm from each other.

Gradually tighten the belt in successive increments until the gap between the two adhesive tapes reaches:

- ① An extension of 0.4% to 0.6%, (0.4% = 251mm and 0.6% = 251.5mm).

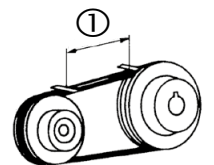

Do not use the existing marks on the belts as a reference.

Tension the belts as shown in the photos below:

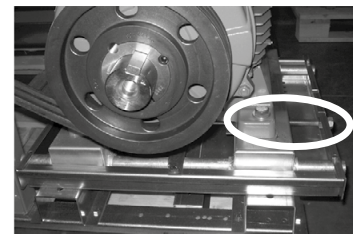
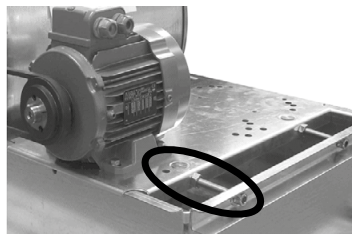
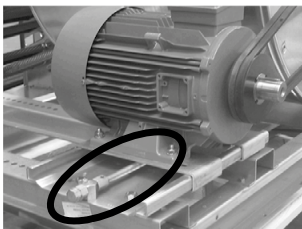

If the drive and/or motor is to be delivered later, proceed as follows:

- Clean the shafts and keys,
- Select the corresponding pulley,
- Insert the pulleys or the bushes,
- Align the pulleys.

3 - INSTALLATION

■ Aligning the pulleys

- ① By placing a ruler flat against the pulley flange and adhering to the data below.
 - ② For variable-diameter pulleys, align them along the centre line.
- Hold the pulleys in place with the appropriate tool,

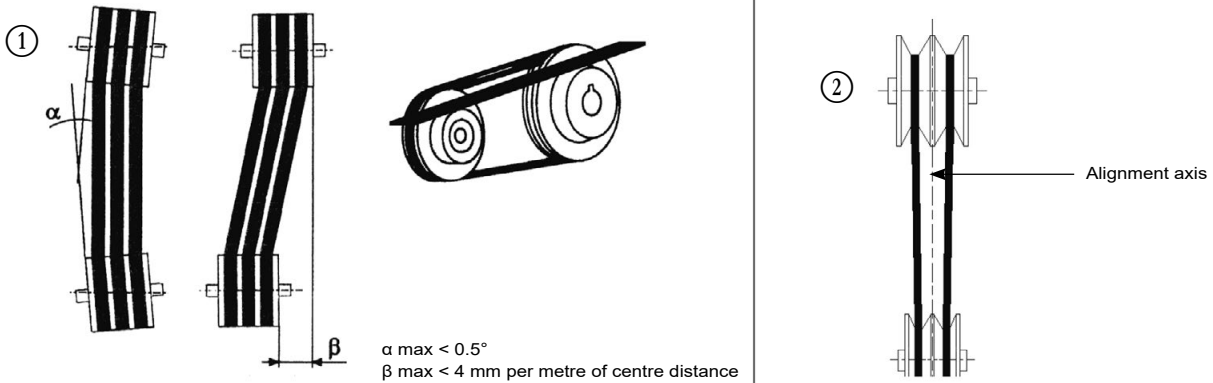

- Fit the belts,
- Tension the belts as instructed in the previous section.

! If changes are made to the drive, make sure that it is compatible with the fan motor assembly, motor current and the suspensions.

■ Direction of rotation of the impellers



Centrifugal fan
Low pressure



Centrifugal fan
Moderate pressure



Plug fan
Seen from intake side

Option: device to measure and check the air flow. Used on centrifugal fans and plug fans.

4 - SYSTEM START-UP

Keep all inspection doors closed while the unit is operating.

A safety device protecting against insufficient air flow must be inserted in the fan control.



Connect all electric components to earth.

4.1 - Connecting the electric motor

The connection must be made by a qualified technician, as per the diagrams below and those included with the motor.



Before powering up the motor, test the insulation resistance. Failure to follow this recommendation will void the motor warranty.

■ Operating mode:

- Before carrying out any work, disconnect and uncouple the motor or the driven machine.
- Measure the motor's insulation resistance before starting it up, particularly if the windings may be wet.
 - The insulation resistance, corrected to 25°C, must exceed the reference value (100 MΩ) (measured under 500 or 1000 V CC).
 - The insulation resistance value is reduced by 50% if the room temperature increases by 20°C.
- Fit the motor casing and discharge the cables against the casing immediately after each measurement to prevent the risk of electric shocks.
- If you do not obtain the reference resistance value, the windings are too wet. They must then be dried in an oven at a temperature of 90°C for 12 to 16 hours, then at 105°C for 6 to 8 hours.
 - During drying, remove the covers from the bleed holes and open the closure valves (if fitted to the motor). Remember to close them after drying. If the bleed caps are fixed, it is recommended to remove the terminal box flanges and covers for the drying operation.
 - Windings which have taken in sea water must normally be rewound.



The motors are equipped with a heat protection sensor which must be connected. Check the supply voltage, the input current and the calibration of the protective devices.



For motors with a power of 5.5 kW or above, we recommend Y/Δ starting in order to limit the starting current (I_d/I_n) and reduce the wear on the drive.

■ Dual voltage type motor with Y coupling, Δ (6 terminals):

230/400 V motor

- 230 V supply voltage, connection (Δ): diagram A.
- 400 V supply voltage: (Y) connection: diagram B.

400/690 V motor

- 400 V supply voltage, connection (Δ): diagram A.
- 690 V AC supply voltage (for P>5.5 kW), connection (Y): diagram B.

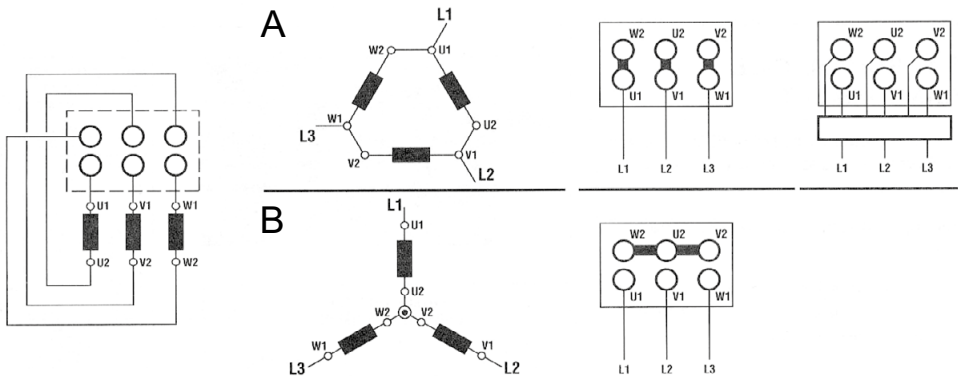

4 - SYSTEM START-UP

■ Dahlander dual-speed motor or motor with reversible poles, 6 terminals.

These diagrams apply to three-phase, 3000/1500 rpm and 1500/750 rpm motors.

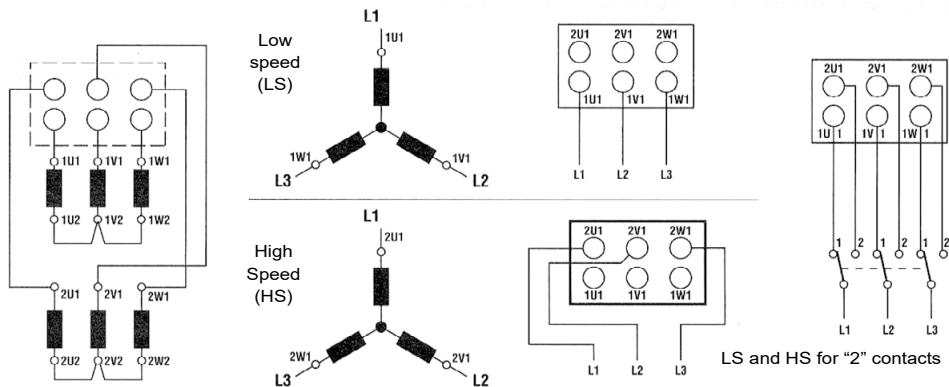

■ Dual-speed motors: two separate windings, 2 x 3 terminals.

These diagrams apply to three-phase, 1500/1000 rpm motors.

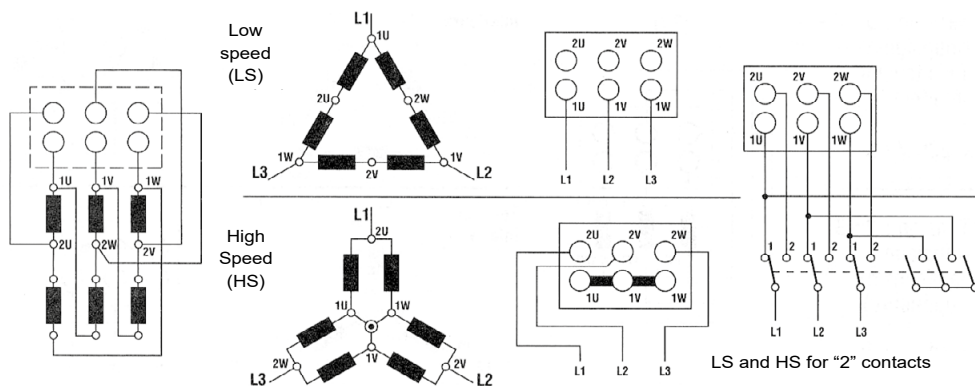

These wiring diagrams are inside each terminal box.

Retighten the connections after 48 hours of operation.

■ Frequency inverters



Recommendations:

- **The motor must be connected to the inverter using a shielded cable;**
- **The sizing of the inverter depends on the distance between the motor and the inverter;**
- **Before starting up the system, the upper frequency must be limited to prevent the maximum speed of the rotating parts from being exceeded or the motor from being overloaded;**
- **Eliminate the frequencies producing resonances by checking the operation of the fan one frequency at a time.**
- **Fit Du/Dt filters on the inverter side for the 690V networks.**

4.2 - Blade damper

Do not turn on the fan with the blades closed.

When the unit is shut down, ensure a time delay on the dampers (or a leakage rate) equal to the fan's inertia time or the time required for the heat to be evacuated from the electric heater.

4.3 - Electric heater



Never operate the coil with the fan off.



Always install a fan delay.

4.4 - Water humidifier

Check the direction of rotation of the pump.

Refer to the documentation delivered with the pump.

5 - MAINTENANCE

5.1 - Casing

The boxes have smooth internal walls. The rate of cleaning will depend on the application and outdoor environment. Check the casing at least once a year.



Do not clean the air handling unit with a high-pressure washer.

5.2 - Dampers

Periodically check the condition and operation of the dampers.

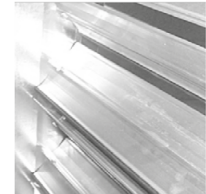
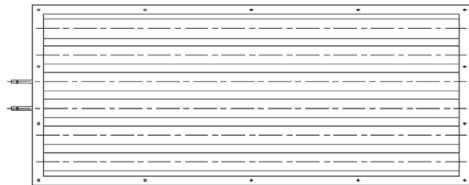

5.3 - Air filters

Filter fouling can be determined by testing the pressure drop.

CIAT's range of AIR air handling units are fitted with pressure tappings.

The various types of filters are shown in section 3.

■ G2 filter

The cells must be periodically vacuumed. To remove greasy dust, the media may be cleaned with warm water (50°C max.) and detergent.

■ G4 filter

G4 cells are generally non-regenerative. They must therefore be replaced as often as necessary. During assembly, make sure that the screen is positioned on the "discharge air" side.

■ HPS bag filters (F6, F7, F8)

Bag filters last a long time but are non-regenerative. They must be replaced when they are clogged. Check the condition of the fasteners and gaskets. Bag filters may be fitted in compressible channels or encased in universal frames with gaskets.

■ High-efficiency and HEP filters (H10-H14)

These come in large-media frames. Follow the assembly and maintenance instructions provided with the cells.



Compressible track



Universal frames

■ Carbon filters

There is no way to know when breakthrough will occur on a carbon filter.

Its service life depends on how it is used:

- Type of impurities to be filtered,
- Concentration of these impurities,
- Average usage time,
- Air flow.

To find out the how long a filter will last under your specific conditions of use, contact the manufacturer of the filter.



Wear gloves and protective clothing when changing the filters. Place the dirty filters inside bags.

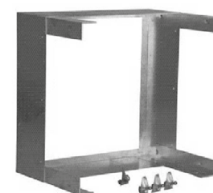

Frame

5 - MAINTENANCE

■ Droplet separator

Depending on the type of extraction, the separator frames can be disassembled as follows:

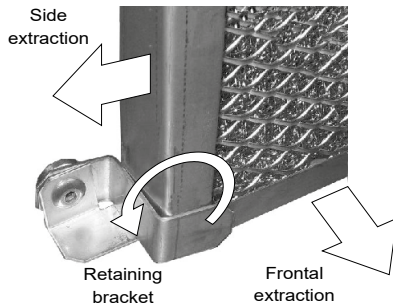

■ Side extraction:

1. Remove the separator's side access panel (4 screws)
2. Pivot the 2 retaining brackets to release the separator (1 at the top, 1 at the bottom)
3. Pull the separator towards you to remove it from the unit

■ Frontal extraction:

1. Open the separator's access door (opening handle)
2. Pivot the 2 retaining brackets to release the separator frames (1 at the top, 1 at the bottom)
3. Detach the frame from its runner in the direction of the air flow (removal via a recess in the runner)
4. If the separator is made up of several frames, slide the second one to position it opposite the recess and detach it, etc.

When refitting, remember to lock the frames using the retaining brackets.

5.4 - Humidifiers



The type of humidifier used and the water quality must comply with the regulations in force.

The upper limit value for non-pathogenic bacteria is 10,000 CFU/ml (Colony Forming Units). However, it is best to check and clean the air handling unit from 1,000 CFU/ml onwards (standard EN 13053). An overflow with siphon must be installed on adiabatic humidifiers. UV treatment and cleaning are recommended.

■ Steam humidifier

Ordinary maintenance simply involves having the steam cylinder replaced and the unit cleaned each year. This must be carried out by a qualified technician.



■ Cleaning or replacing the steam cylinder

This is necessary when deposits on the active surface of the electrodes prevent normal current flow (alarm E06, E08).

Disassemble the cylinder as follows:

- Press the manual drain button to completely empty the water in the cylinder,
- Remove the cylinder steam hose,
- Disconnect the main electrodes and the level electrodes,
- Remove the retaining spring and twist off the cylinder.

The steam cylinder can generally be reused after descaling (scale on the electrodes prevents the free flow of water and current).

Unscrew the clamp and remove the bottom filter. Flush away any mineral debris in the cylinder under running water and clean the grilles with an off-the-shelf cleaner.

Replace the cylinder if the electrodes are too badly corroded. Only the cylinder body and O-ring need to be changed (do not change the capping ring, seat or filter).

Reassemble the cylinder by following the above steps in reverse order after checking or replacing (if necessary) the seal between the coupling and the drain unit.

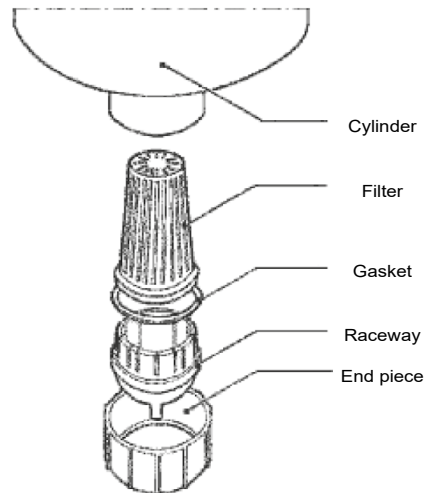

■ Cleaning the unit and seasonal servicing

Check and clean the unit once a year. Drain the unit and disconnect it from the power source before doing so:

- Disassemble or wash the water supply valve and check the cleanliness of the inlet filter,
- Remove the drain unit and clean the lines and nozzles,
- Inspect the water supply, steam supply and condensate drain pipes and replace them if necessary.

■ Servicing frequency

- Check the connections each time the air handling unit is turned on,
- Check the condition of the cylinder. If necessary, replace it once every three months,
- Retighten the electrical connections and check the components and correct diffusion of steam each year.

For further information, refer to the manufacturer's instructions delivered with the unit.



5 - MAINTENANCE

■ Water humidifier

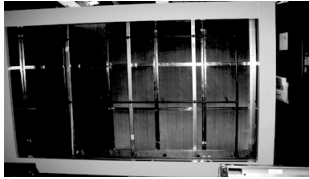

fig. A

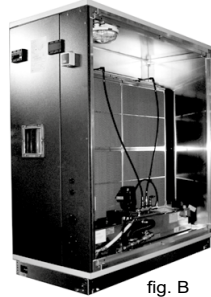

fig. B

- Spray (Fig. A)

It is recommended to service it twice a year:

- Clean the pan,
- Check the drain outlets,
- Check the cleanliness of the runoff screens (if a problem is found, check the upstream filtration or the water pH) and correct as necessary,
- Replace the screens if necessary,
- Clean the spray washers (option).

For further information, refer to the instructions delivered with the unit.

- Run-off (fig. B)

It is recommended to service it twice a year:

- Clean the pan,
- Check the drain valve flow rate,
- Check the drain outlets,
- Check the cleanliness of the cell module.

5.5 - Fan motor assembly

Theoretically, the scroll housing, impeller and shaft require little servicing unless the air drawn in is dirty and unbalances the impeller.

If the air is very dirty, check the filters and their assemblies.

Once a year check the anti-vibration mounts, the sleeve seals, etc.

■ Bearings

The rate at which the bearings require servicing depends on the fan usage conditions.

Most of the fans are fitted with permanently lubricated bearings. Under normal operating conditions, they will last for 20,000 hours of operation.

Special lubricants may be used for certain applications.

We recommend lubricating other bearings once every 7,000 hours of operation.

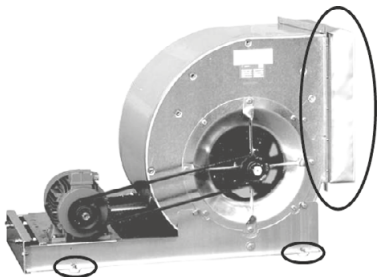

■ Drives

Refer to section 3 on the fan motor assemblies.

5.6 - Sound attenuator

No special servicing is required for the sound attenuator baffles. However, we recommend checking the outside once a year to avoid fibres coming loose and clogging the filters downstream.



5.7 - Heat recovery units

■ Plate recovery units

Once a year, dust off and degrease the plate heat exchangers and service the control valve if a bypass is fitted.

Also check the frost protection coil upstream of the cross-flow exchangers.

■ Thermal wheel recuperators

Check the maximum and minimum rotation speeds once a year.

Dust and humidity build up at the bottoms of rotary heat exchangers when they are not in use.

Clean them if they not to be used during extended periods.

Check the permanently lubricated bearings once a year.

If assembled with a speed controller (variable-speed thermal wheel recuperator), refer to the manufacturer's instructions

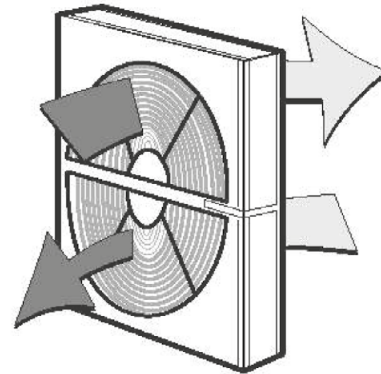

■ Rotor

Periodically check both sides of the rotor for dirt. Clean off any dirt with compressed air. A suitable detergent may be used to clean off stubborn dirt.

Also check if the upstream filters are clean and ensure a tight peripheral seal.

■ Heat exchangers on coils filled with glycol/water mix

Refer to section 3.

■ Heat-pipe heat exchangers

Refer to section 3.

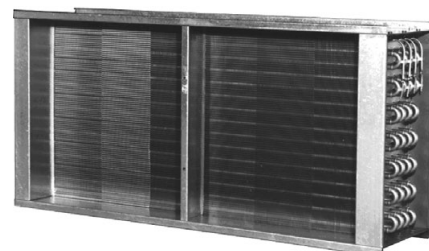

5 - MAINTENANCE

5.8 - Preventive maintenance

All equipment must be serviced and commissioned by qualified personnel.

COMPONENT	OPERATIONS REQUIRED	RECOMMENDATION
FAN	Check the cleanliness of the housing	3 months
	Check the impellers or rotating parts (visual check)	3 months
	Check the bearings (noise)	3 months
	Lubricate (depending on fan)	Every 20,000 to 30,000 hrs
	Check the mounts (visual check)	3 months
	Check the fasteners (visual check)	3 months
	Check for corrosion	6 months
MOTOR	Check the bearings (noise)	3 months
	Check the fasteners (visual check)	3 months
	Check the connections	6 months
DRIVE	Check its condition. Replace if necessary.	3 months
	Check the tension of the belts	3 months
	Check the alignment	3 months
	Check for vibrations and retighten the casing	3 months
FILTRATION	Regularly check the fouling level	3 months
	Check entire assembly for leaks	3 months
	Replace	as recommended by the manufacturer
SOUND ATTENUATOR	Check the cleanliness of the baffles	3 months
	Check for tears in the baffles	3 months
COIL	Check the cleanliness	3 months
	Check the level of antifreeze	varies by operating conditions
	Drain the coil	varies by operating conditions
BURNER	Service and adjust (gas qualification)	Before start of warm-up
HUMIDIFIER		see humidifier manual

This table relates to "standard" use of our units and is provided for guidance only. Servicing frequency rates must therefore be adjusted based on your conditions of use.

5.9 - Cleaning the units

On site: Keep the units wrapped for as long as possible. Upon unwrapping them, immediately make the air connections and keep the boxes closed.

Before turning on and installation, vacuum the inside of the air handling units and, if necessary, clean the panels with a spray bottle of solution and a soft cloth. Start up the system with just the prefilters (dust in the ducts, etc.). Wait a few hours; change the filters if necessary and then fit all the filter stages.

■ Cleaning in cleanrooms and associated controlled environments

Follow the procedures in force on the site of installation.

Cleaning and decontamination can be reduced to a strict minimum with the right filtration and by following the relevant procedures.

High-pressure washers are sources of contamination and therefore prohibited. Clean with either a spray bottle filled with a cleaning solution or disinfectant and soft cloth or special wipes.

Reminder: Contaminants may be brought in each time a door is opened in a cleanroom or associated controlled environment.

6 - WARRANTIES

6.1 - Duration of warranty on coatings applied to outdoor air handling units

SQ - 2PR - DC - C - 003 - Rev. B

CIAT provides a **ten-year warranty** for the coatings applied to its outdoor air handling units.

This warranty takes effect from the date of delivery and covers the repair of parts determined to be defective by the fitter and CIAT. It does not cover labour. It does not cover labour.

The warranty applies to holes on the outer surface caused by corrosion.

Application of this warranty is subject to annual on-site inspections by the fitter and CIAT at the operator's request. An inspection report shall be drawn up after each inspection.

The unit shall be installed in normal outdoor conditions, i.e. outside industrial polluted areas containing SO₂ and NH₃, outside coastal areas subject to salty air, and outside thermal areas where the air contains sulphur or is heavily laden with chlorine.

Units that are installed outdoors shall be protected by a rain shield manufactured by CIAT and installed according to accepted engineering standards. Said shield shall be sloped appropriately to allow proper water runoff (the presence of any standing water shall void this warranty).

The operator of the unit shall take out a maintenance agreement with a recognised, qualified firm and inform CIAT of the name of said firm. The unit shall be inspected and cleaned each year. The records of such operations shall be kept by the customer. Any damage (scratches, dents, etc.) to the unit between inspections shall be reported to CIAT, which, after inspecting and possibly repairing said damage, shall determine whether to maintain or void the warranty.

The warranty shall not cover:

- Damage caused by neglect, misuse, or failure to follow the requirements listed hereinabove or given in the maintenance and commissioning manual.
- Costs resulting from failure of the unit to operate.
- Damage to the air handling unit attributable to an outside cause, in particular damage to the coating by impacts, air pollution, animals or mildew, moss and mould.
- Damage caused by natural phenomena (such as hail).
- Damage caused by accidents.

6.2 - Duration of the air handling unit warranty

SQ - 2PR - DC - C - 004 - Rev. B

CIAT provides a **5-year warranty** for the AHU stationary parts. This warranty does not extend to moving parts and wear parts, such as fans, motors, variable drives, dampers, thermal wheel recuperators, filters, belts, bearings and lights

This warranty takes effect from the date of delivery and covers the repair of parts determined to be defective by the fitter and CIAT. It does not cover labour. It does not cover labour.

This warranty applies to defective parts.

Application of this warranty is subject to annual on-site inspections by the fitter and CIAT at the operator's request. An inspection report shall be drawn up after each inspection.

The unit shall be installed in normal outdoor conditions, i.e. outside industrial polluted areas containing SO₂ or NH₃, outside coastal areas subject to salty air, and outside thermal areas where the air contains sulphur or is heavily laden with chlorine and which could result in abnormal corrosion. Furthermore, the air it will handle must be free of the aforementioned compounds.

Units that are installed outdoors shall be protected by a rain shield manufactured by CIAT and installed according to accepted engineering standards. Said shield shall be sloped appropriately to allow proper water runoff.

The operator of the unit shall take out a maintenance agreement with a recognised, qualified firm and inform CIAT of the name of said firm. The unit shall be inspected and cleaned each year. The records of such operations shall be kept by the customer.

The warranty shall not cover:

- Damage caused by neglect, misuse, or failure to follow the requirements listed hereinabove or given in the maintenance and commissioning manual.
- Costs resulting from failure of the unit to operate.
- Damage to the air handling unit attributable to an outside cause, in particular damage to the coating by impacts, air pollution, animals or mildew, moss and mould.
- Damage caused by natural phenomena (such as hail).
- Damage caused by accidents.

7 - SPECIAL INFORMATION FOR ATEX AREAS

In accordance with directive 2014/34/UE (explosive atmospheres)

7.1 - General information

- Evaluation of the level of danger of explosion established in accordance with standards NF EN ISO 80079-36, NF EN ISO 80079-37 and EN 1127-1.
- The user must classify the various potentially explosive areas in accordance with directive 1999/92/EC.
- The air handling units are selected and manufactured based on the type of area defined by the user.



A unit must never operate under conditions other than those it was designed for.

7.2 - Marking

Each unit is supplied with an ATEX Conformity Certificate; the ATEX marking is inscribed on the name plate as shown below:

Example:  **II 2G/3G Ex h IIB / IIC**
(or IIB + H2) T...°C or TX Gb/Gc (*)

- * The labelling and the equipment integrated into the unit are adapted according to the conditions defined by the customer in the sheet completed prior to ordering

: standardised ATEX logo

II: Group II = surface industries

Equipment category (2 or 3 depending on zone 1 or 2).

- Ex h: Regulatory markings according to standard NF EN ISO 80079-36:2016
- Gas group subdivision IIA, IIB or IIC
- The IIB labelling is suitable for gas group subdivisions IIA and IIB.
- For group IIC, in the presence of hydrogen, depending on the labelling of the integrated components, the device labelling may be IIB + H2
- TX (indicates the maximum permitted surface temperature) may either:
 - Be replaced in the labelling by the temperature class given in the operating conditions defined by the customer - T1 (450 °C) to T6 (85 °C).
 - State the actual temperature (Preceded by the letter T and followed by the unit °C).
- EPL: ("Explosion Protection Level") G for gas, followed by the level b or c depending on the category of equipment.

For category 2, a copy of the technical conformity dossier is saved and archived for 10 years by a notified body. The archiving number for the dossier is sent to the customer.

7.3 - System start-up, maintenance

- The units must be installed and commissioned by a qualified professional.
 - All the provisions set out by the current directives and standards must be respected during installation, for example, automatically linking the unit's supply to the presence of a flow rate detected by a sensor.
 - In all cases, refer to the general information section of this manual, to the specific manuals for the ATEX components built into the unit and listed in the ATEX dossier, and to the specific precautions below:
 - Install the units so that the temperatures at and around the intake are between – 20 and + 60 °C.
 - The units and the additional metal elements must be connected electrically by a grounding cable linked to the frame.
 - Select and install all the electrical connection and control components according to the risk zone in which they will be installed.
 - All remote metal components (sheaths, pipes, etc.) must be grounded, if necessary by grounding cables.
 - Always connect the motor heat protection (see § 4 – SYSTEM START-UP)
 - The installer must use all available devices to ensure that the temperature of the various elements of the installation remains below the autoignition temperature of the gas and/or the dust in question.
 - If the connections to the various pieces of built-in equipment require feeding through walls (passage of cables, sensors, etc.), these feedthroughs must be sealed to prevent the "ATEX" atmosphere from dispersing. The same is true for the connections between the various blocks which form the unit and for the connections to the ducts.
 - Any modification to the unit without prior approval from the manufacturer is prohibited.
 - Ensure that, during assembly or maintenance operations, no element (tools, screws, components) are left in the unit, as this could cause a dangerous situation to arise (see section "Information concerning the use of tools in explosive atmospheres").
 - Prior to any maintenance operation, ensure that the unit is powered off.
 - After each maintenance operation, check that all the removed components have been refitted and secured in their original position.
 - Ensure that the ground straps are in good condition and reconnected.
 - Regularly check that removable components, such as enclosures or covers, and movable components, such as damper blades or filter runners, are secure.
- **Exchanger coils:**
- The temperature of the fluids circulating in the coils must not exceed the value given on the unit's name plate.
 - It must be below the surface temperature limit (or temperature class) corresponding to the ATEX atmosphere for which the unit is certified. (see § 7.2)

7 - SPECIAL INFORMATION FOR ATEX AREAS

■ Fan surface area:

- Respect the recommendations given by the motor and fan manufacturers in the manuals appended to the ATEX dossier.
- For belt pulley systems, the belt tension must be regularly adjusted and checked. A slack belt can slip and reach high temperatures. The frequency for these checks is once a week. This frequency must be adapted to the observations made during previous checks (condition of the belt, stability of the settings) and the ATEX risk.
- Only use non-flammable, antistatic electrically conductive belts adapted to the unit's ATEX atmosphere.

■ Air filter:

- For ATEX units (in categories 2 - zone 1 - and 3 – zone 2 or 22 -), only use ATEX-certified antistatic filters, compatible with the zone and the gas and/or dust group.
- To limit the deposits of dust in the units installed in zone 22, you must:
 - Change the filters as soon as the average fouling level has been reached.
 - Each time the filters are changed, completely clean the unit using a vacuum cleaner (see specifications in § 7.4 relating to this type of equipment), and more specifically around the elements where the temperature is highest (heat exchange coils, fan motor assembly, etc.).
 - Ensure that the ground straps for the filter cells are reconnected, and check that they are in good condition before restarting.

■ Electrical connections:

- **All electrical connections must be performed by qualified, ATEX-approved personnel. Under no circumstances may CIAT be held liable for the performance of these connections, which are outside its scope of services.**

■ Prevention of corrosion:

- If any rust appears, sand the corroded surface with an emery cloth, clean, then protect with rustproof, anti-electrostatic paint.

7.4 - Using tools in an explosive atmosphere







- The operating managers for the installations and processes which include explosive atmospheres must provide all persons working on a site with information relating to using manual tools in complete safety. There are two different types to be taken into consideration:

Type A: Tools liable to only produce single sparks when used, such as screwdrivers, spanners or impacts wrenches, for example;

Type B: Tools that generate a plume of sparks, which may be used during grinding or sawing operations.

- In zones 1 and 2 (or 22), only type A tools are permitted; use of type B tools can only be authorised if no dangerous explosive atmosphere is present within the working area.
- In zone 1, and in the presence of substances belonging to group IIC (acetylene, carbon disulphide, hydrogen) and hydrogen sulphide, ethylene oxide, carbon monoxide, if there is a risk of explosion due to the presence of these substances, the use of steel tools is prohibited unless it can be assured that no dangerous explosive atmosphere remains in the place of work whilst these tools are being used.
- Type A steel tools can be authorised in zone 22; type B steel tools can only be used if the place of work is separated and protected from the remaining zone 22 locations and if the following additional measures are taken:
 1. All dust deposits have been removed from the place of work or,
 2. The place of work is kept sufficiently humid so that no dust can be dispersed into the air and no smouldering fire is liable to develop.
- During grinding or sawing operations in zone 22 or close to such a zone, it is possible that any sparks produced could be projected large distances and thereby form glowing particles. For this reason, the other zones around the place of work must also be included in the protective measures mentioned above.
- The use of tools in zones 1, 2 and 22 must be subject to the "work permit" system.
- All other types of tools or equipment required for maintenance operations (vacuum cleaners, etc) must be compatible with use in the ATEX zone in question. Otherwise, it must be ensured that, prior to and for the duration of any maintenance operation, the place of work is sufficiently ventilated to prevent the presence or formation of an explosive atmosphere.

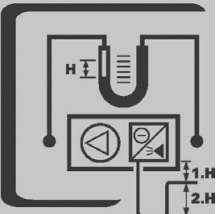
8 - MEANING OF THE PICTOGRAMS

	<p>Water outlet</p>		<p>Water inlet</p>
	<p>Air flow direction</p>		<p>Monitor the cleanliness of the filters</p>
	<p>Condensate drain siphon</p>		<p>Electric heater</p>
	<p>Grounding compulsory</p>		



Declaration of Conformity UE

This unit complies with the provisions of European Directives:

2006/42/EC (Machinery)

2014/30/EU (EMC)

2011/65/EU (RoHS)

2009/125/EC (Eco Design)

and regulation 327/2011/EU & 1253/2014/EU

REGULATION (EC) No 1907/2006 (REACH)



UK Declaration of Conformity

This unit complies with the requirements of:

Supply of Machinery (Safety) Regulations 2008

Electromagnetic Compatibility Regulations 2016

The Restriction of the Use of Certain Hazardous Substances in Electrical and Electronic Equipment Regulations 2012

The Ecodesign for Energy-Related Products and Energy Information Regulations 2019, and following amendments

UK REACH Regulations 2019

UK Importer:

Toshiba Carrier UK Ltd, Porsham Close, Roborough, Plymouth, PL6 7DB

