

EN7486825-09

07 - 2023

CLIMACIAT®



Instruction manual



CONTENTS

1 - GENERAL INFORMATION	4
1.1 - Intended use.....	4
1.2 - Documentation.....	4
1.3 - Warranty.....	4
2 - SAFETY INSTRUCTIONS	5
3 - REGULATIONS	6
3.1 - General information.....	6
3.2 - Regulations.....	6
3.3 - Accreditation.....	7
3.4 - Pressure and temperature.....	7
4 - IDENTIFICATION	8
4.1 - Data plate.....	8
4.2 - Pictograms.....	9
5 - SHIPPING - DELIVERY - HANDLING	10
5.1 - Shipping instructions.....	10
5.2 - Container shipment.....	10
5.3 - Delivery.....	10
5.4 - Instructions for lifting and handling.....	11
5.5 - Anchoring points for handling the block fitted with transport feet.....	13
5.6 - Storage.....	14
6 - INSTALLATION	15
6.1 - Warning.....	15
6.2 - Choise of location.....	15
6.3 - Assembling the blocks.....	19
6.4 - OPTIONS: Adjustable feet, risers and risers + cylinders.....	23
6.5 - JUXTAPOSE FUNCTION sealed junction special features.....	24
6.6 - Roof/canopy (Accessories).....	25
7 - CONNECTIONS	32
7.1 - Condensate drain siphon.....	32
7.2 - JUXTAPOSE function SPECIAL FEATURE.....	32
7.3 - Droplet eliminator.....	33
7.4 - Electric heater.....	35
7.5 - Connecting the disconnect switches/circuit breakers.....	36
7.6 - Connecting the fans.....	37
7.7 - Filters.....	43
7.8 - Different filter locking systems:.....	43
7.9 - Standalone steam humidifier.....	44
7.10 - Damper and mixing.....	45
7.11 - Heat recovery units.....	47
8 - CONTROL	49
8.1 - AHU with control.....	49
8.2 - AHU without control.....	49
9 - COMMISSIONING	50
9.1 - Siphon.....	50
9.2 - Pre-commissioning check.....	50
9.3 - Filters.....	50
9.4 - Fan.....	51
9.5 - Heating and Cooling coil.....	53
9.6 - Electric heater.....	55
9.7 - Steam humidifier.....	55
9.8 - Damper and mixing.....	56
9.9 - Heat recovery unit.....	57
9.10 - Check after start-up.....	60

CONTENTS

10 - OPERATION AND MAINTENANCE	62
10.1 - General recommendations for cleaning	62
10.2 - Filters	62
10.3 - Fans	63
10.4 - Heating/cooling coil	64
10.5 - Electric heater	65
10.6 - Steam humidifier	66
10.7 - Damper and mixing	66
10.8 - Sound attenuator	67
10.9 - Heat recovery units	67
10.10 - List of checks and maintenance	69
10.11 - Specific DIN1946-4 and VDI 6022 maintenance	70
10.12 - Prolonged downtime	70
11 - SPECIAL INFORMATION FOR ATEX AREAS 	71
11.1 - General information	71
11.2 - Labelling	71
11.3 - System start-up, maintenance	71
11.4 - Using tools in an explosive atmosphere	72
11.5 - Check - Periodic inspections	73
11.6 - ATEX control sheet	74
12 - FINAL SHUTDOWN	75
12.1 - Shutting down	75
12.2 - Recommendations for disassembly	75
12.3 - Materials to be recovered for recycling	75
12.4 - Fluids to be recovered for recycling	75
12.5 - Waste electrical and electronic equipment (WEEE)	75

1 - GENERAL INFORMATION

- Thank you for choosing our air handling unit. The design and construction of your unit are the fruit of all the expertise offered by our company's teams of technicians.

1.1 - Intended use

- The air handling units are designed for use indoors or outdoors (canopy and roof option mandatory)
- The units are intended to provide ventilation and, depending on the composition:
 - Filtration of normal quality air,
 - Filtration of air in sterile environments (special version for clean rooms),
 - Air heating and/or cooling,
 - Air humidification and/or dehumidification,
 - Heat evacuation or recovery,
 - Filtration and handling of particularly moist and/or contaminated air (special versions, e.g. for extracting air from swimming pools or kitchens),
 - Or a combination of the above characteristics.
- Any use other than that described above is deemed improper.
- If necessary, check whether your units are compatible with the applications for which you intend to use them.
- The manufacturer is not responsible for damage resulting from improper use.
- The user shall be held solely responsible.
- Your machine's specific operating conditions are set out in the contract review.
- The standard machine is designed to operate in urban and industrial environments with class C3 moderate pollution in accordance with standard ISO 12944. Other options are available on request for more polluted environments or coastal areas.



The sharp increase in the air pressure when the fire damper is closed may cause irreversible damage to the plate heat exchangers.



Take into account the quality of the ambient air and the conditioned air.

1.2 - Documentation

- This manual contains all of the installation and operating instructions for your unit. This document must be read in full before carrying out any work on the unit. This manual must be kept in the immediate vicinity of the unit. It does not cover the entire installation.
- Please read all of the documents supplied with your order for information concerning the installation and system start-up steps.
- Depending on the options selected, specific handbooks may be included with this manual, and are also available from your manufacturer. You should also read these handbooks before installing any options or carrying out any work (e.g. speed variator, humidifier, control, etc.),
- Devices installed and used in ATEX zones are marked with this symbol . A specific section of this manual is dedicated to the limits of use and the precautions to be taken when installing, starting up and maintaining these devices. Refer to this section before installing or carrying out any work.

1.3 - Warranty

- See general terms and conditions of sale.
- Any modification made to the unit by persons other than the manufacturer's employees, or without prior consent, shall result in cancellation of the warranty.

2 - SAFETY INSTRUCTIONS



- The air handling units are designed in compliance with recognised safety rules.
- Unauthorised persons and the general public must be prevented from accessing this device.
- These units must be used in perfect condition and within their field of application.
- Only qualified technicians may work on the machine. They must have all the necessary Personal Protective Equipment (PPE): glasses, gloves, safety shoes, hearing protection, dust mask, etc.
- Check the following points before carrying out any work on the air handling unit.
 - A 1 minute fan delay, no less, must be applied after the electric heaters and gas heating systems are shut down to allow complete cooling. This delay must be adjusted as per the damper actioners rotary speed, but must not be less than 1 minute.
 - Equipment lock-out in accordance with standard EN 60204/DIN VDE 0113.
 - **Warning: depending on the options selected, there may be several different power supplies on the various units (main unit, supply unit for electric heaters, humidifier), Make sure all power supplies are cut and locked out.**
 - All moving or rotating parts must be shut down.
 - Wait at least 15 minutes if using a frequency inverter (resultant voltage),
 - All of the casings must be at atmospheric pressure before work can be carried out.
 - Wait until the heat exchangers have cooled (heaters, steam, hot water coils),
 - Make sure there are no foreign objects in the air handling units before starting them up.
- For units that can be entered, an "internal handle" option is available to prevent accidental entrapment.

During any servicing operations, all the recommendations and instructions given in the maintenance brochures, on the labels or in the instructions accompanying the equipment must be observed, along with any other applicable safety instructions.

- Observe all the regulations in the safety codes.
- To prevent any risk of accident, prohibit public access by clearly marking the work area.
- Wear all the required Personal Protective Equipment (PPE),
- Follow the handling instructions.
- Handle heavy and bulky equipment with care when lifting, handling and setting down.
- Technicians who install, commission, operate and service the unit must understand the instructions given in this manual and be familiar with the specific technical characteristics of the installation site.



For your safety, we recommend the use of PPE (Personal Protective Equipment)

PROTECTION AGAINST ELECTROCUTION

Only personnel qualified in accordance with the IEC (International Electrotechnical Commission) recommendations must be allowed to access the electrical components. It is particularly recommended that all the electrical supplies to the unit are switched off before any work is carried out. Cut the main power supply using the disconnect switch or circuit breaker.



The control system includes electronic components. These may cause or be subject to electromagnetic disturbance if they are not installed and used in accordance with these instructions.

Before carrying out any work on the frequency inverters (heat recovery wheel, etc.), disconnect the power supply and ensure that these are not live. After disconnection, you must wait 5 minutes before starting work (necessary for the capacitors to discharge),

3 - REGULATIONS

3.1 - General information

- Always follow and comply with the instructions in this manual and the regulations and legislation in force in the country of use.
- Any modifications or welding to pressurised parts is dangerous and may be prohibited by regulations.
- The use of this equipment under seismic loads has not been verified.
- The units **MUST NOT** be stacked.

3.2 - Regulations

The manufacturer declares under its sole responsibility that this air handling unit, operating under the conditions provided for in the product definition, complies with the provisions of the following directives and regulations.

It is up to the installer to carry out an additional risk analysis when integrating the equipment into its environment. For example, if the equipment is not installed in a controlled area to which only authorized personnel have access - i.e. if a door can be opened while the machine is running - then additional measures, such as the installation of our protection grid option, are required.

For any machine supplied without regulation, the installer assumes the manufacturer's obligations and must carry out a full risk analysis. It is the installer's responsibility to ensure compliance of the machine with the control system supplied. We accept no liability for any damage to persons and/or property resulting from inadequate safety or improper use. Some important recommendations are listed in §8.2



Declaration of Conformity UE

This unit complies with the provisions of European Directives:

2006/42/EC (Machinery)

2014/30/EU (EMC)

2011/65/EU (RoHS)

2009/125/EC (Eco Design) and regulation 327/2011/EU & 1253/2014/EU

REGULATION (EC) No 1907/2006 (REACH)



UK Declaration of Conformity

This unit complies with the requirements of:

Supply of Machinery (Safety) Regulations 2008

Electromagnetic Compatibility Regulations 2016

The Restriction of the Use of Certain Hazardous Substances in Electrical and Electronic Equipment Regulations 2012

The Ecodesign for Energy-Related Products and Energy Information Regulations 2019, and following amendments

UK REACH Regulations 2019

UK Importer:

Toshiba Carrier UK Ltd, Porsham Close, Roborough, Plymouth, PL6 7DB

3 - REGULATIONS

3.3 - Accreditation

- The following accreditation is required to work on the unit:
 - Electrical qualification (in accordance with regulations) for working near the unit or on the electrical components.
- Technicians who install, commission, operate and service the unit must have received the necessary training and certification, understand the instructions given in this manual and be familiar with the specific technical characteristics of the installation site.
- All work on the refrigerating circuit must comply with directive EC No. 842/2006.

3.4 - Pressure and temperature

- Maximum permissible pressures (OP):
 - Water or glycol/water mix type heat exchanger: 8 bar.
 - Superheated water type heat exchanger: 12 bar.
 - Steam heat exchanger: 12 bar.
 - Refrigeration heat exchangers: Group 2 refrigerants: 42 bar.
- Test pressure (TP): In accordance with § 5.3.2.2 a and 6.3.3 iii of standard 378-2, the pressure test (PT) is performed on model representative of all 3 x PS assemblies.
- Transport temperature: -40°C/+75°C.
- Storage temperature: min.: -40°C, max.: +75°C.
- Operating temperature outside the air stream:
 - Normal operation: min. -20°C, max. +50°C.
 - Specific operation: min. -30°C, max. +75°C (consult the manufacturer),
- Operating temperature in the air stream:
 - Normal operation: min. -20°C, max. +50°C.
 - Specific operation: min. -30°C, max. +80°C (consult the manufacturer),



Our units are designed for altitudes of up to 1000 m. For higher altitudes, consult the manufacturer. The altitude may significantly affect the unit's performance due to the air density.

4 - IDENTIFICATION

4.1 - Data plate

- Each unit has a manufacturer's name plate bearing an identification number and the unit designation. Make sure this information matches that on the order.

Réf. Produit / Item Ref.		Désignation / Description	
An / Year N. Serie : Serial Nbr		Composant / Composant	
Repère / Part		Batterie élec / Elec Heater	
TOTAL INTENSITE / CURRENT		Autres / Other parts	
P.ABSORBEE / INPUT		INTENSITE / CURRENT	
Batterie Frigo		Batterie Liq L2	
POIDS / WEIGHT SERVICE		N° Déclaration CE	

- Data:
 - Réf. Produit (Item ref.):
 - Désignation (Description): Type.
 - An (Year): Year of manufacture.
 - N° série (Serial Nbr): **Number to be quoted in all correspondence.**
 - Composant (Component):
 - Repère (Part):
 - Batterie élec / Elec Heater: if option chosen "3 50Hz 400V"
 - Autres / Other parts: could be "3+N 50HZ 230/400V" or "3 50HZ 400V"
 - TOTAL INTENSITE / CURRENT: if sum possible
 - P.ABSORBEE / INPUT: Power input in W..
 - INTENSITE / CURRENT:
 - Batterie Frigo: if option chosen Fluid (type), Max temp., Pressure max adm.
 - Batterie Liq L2: if option chosen 110C / 8BARS or similar
 - Batterie vapeur G2 : if option chosen 150C / 12BARS or similar
 - POIDS / WEIGHT SERVICE: Weight (in kg) of the unit in service.
 - N° déclaration CE (EC declaration no.):
- For the electrical consumption of humidifiers and autonomous fire detector, please refer to their own labels.
- If the lighting option has been selected, a specific 230 V power supply is required.
- Markings (data plate, punch marks, labels) must remain visible. They must not be altered, removed or modified.

4 - IDENTIFICATION

4.2 - Pictograms



Heating coil



Filter



Electric heater



Electrics box



Cooling coil



Steam humidifier



Steam coil



Stop-drop



Adiabatic humidifier



Fan



Discharge siphon

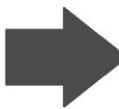

Air flow



Sound attenuator



Coil outlet arrow



Coil inlet arrow



Fire danger



Plate recovery unit



Pressure tapping



Rotary heat exchanger

5 - SHIPPING - DELIVERY - HANDLING

5.1 - Shipping instructions

- Our units must be shipped in their original packaging and in the position in which they will be used.
- Blocks must not be stacked.
- Transshipment is not permitted.
- During shipping, the load must be lashed to the truck bed to prevent the unit from moving and being damaged.
- Lashing must follow accepted industry practice, using straps made from standardised synthetic fibres (EN12195-2), clearly marked and labelled and in perfect condition.
- Leave a space of at least 100 mm between the 2 units.
- Use anti-slip blocks under the unit's feet.
- We recommend top-over lashing. The straps must be tensioned manually, enough to hold the equipment securely on the truck bed without damaging.

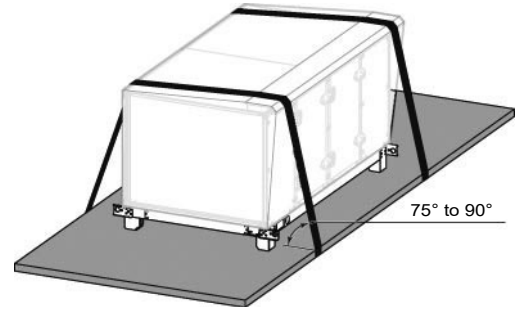

Do not use mechanical implements such as levers, bars, etc., unless the tensioning device is specially designed for use with such implements.

5.2 - Container shipment

- The container dimensions must be adapted to those of the equipment being shipped.
- Slide the unit onto the container floor. When using a fork lift, place a spacer between the frame and the fork lift to prevent damage to the unit's casing and accessories.
- The straps are fed through the lifting lugs on the frame to remove the unit from the container:
- Remove the unit from the container by pulling the 2 straps.
- Depending on the size and configuration, the units can be shipped in one or more blocks.
- Units supplied assembled on a frame:
- Steel mounts and pads, painted red, underneath the frame are used for removing the unit from the container and must be removed before positioning it on site.
- Do not lift the unit by its accessories.

5.3 - Delivery

- Upon delivery of the unit components, inspect the consignment in the presence of the driver. If any damage is observed, or if the delivery is incomplete, indicate this in the usual way on the delivery note and confirm to the carrier by registered letter within three days of the delivery date and send a copy to us. Take photographs of any damage.
- Delivery of stacked blocks: in the case of an outdoor unit or with control option, the cable raceways are supplied not fitted, and can be found between the blocks on the upper panel (see image below),

Stacking of AHU_005 to 045

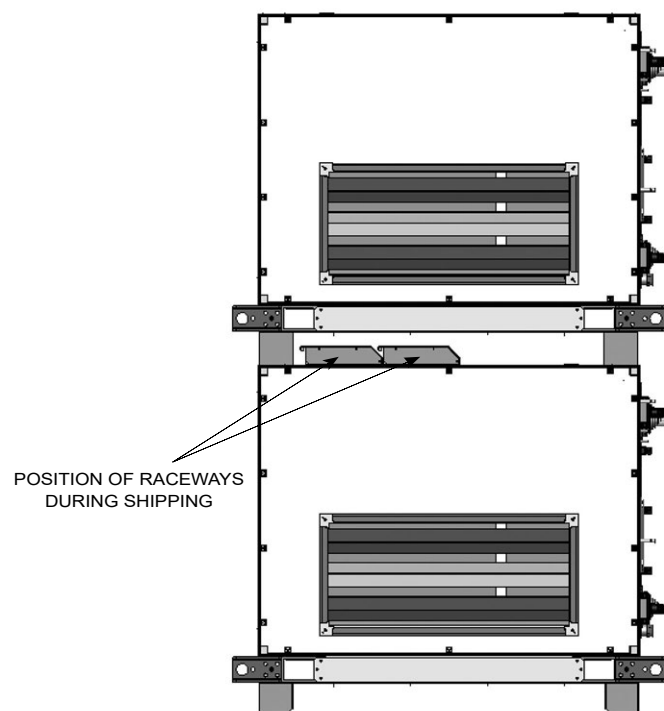

5 - SHIPPING - DELIVERY - HANDLING



WARNING: never use the terms "pending unwrapping" or "unit damaged, packaging intact", as these are not admissible for insurance purposes.

For any other problem, your contact will be able to explain the relevant procedure.

5.4 - Instructions for lifting and handling

- All of our units are supplied with lifting lugs.
- All lifting and handling operations must be carried out in accordance with the standards and regulations applicable to the handling location and using standardised equipment.
- When handling, use lifting straps with a sufficient lifting capacity. Do not use damaged straps. Use a lifting beam adapted to the size of the unit to prevent the straps from exerting pressure on the unit, its accessories or the roof.
- When handling with a pallet truck or fork lift, make sure the forks are long enough to avoid damaging the casing. The forks must project beyond the other side of the block.



The blocks must only be connected after handling and during installation.

It is forbidden to handle connected blocks unless they are fully supported by a suitable common structure.

Lifting and handling a block

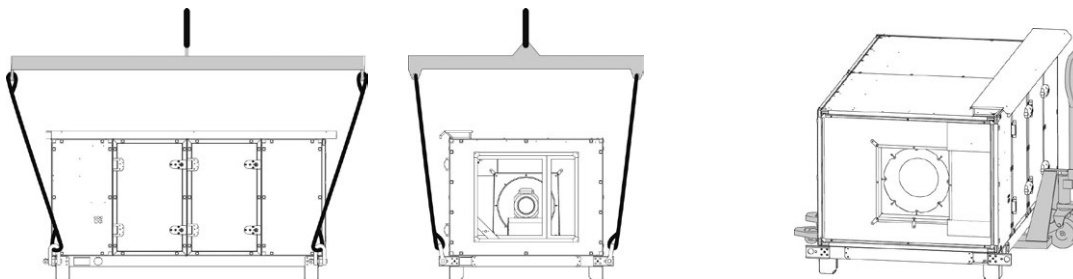

Lifting the unit on a packaged unit frame

- 2 endless round slings:

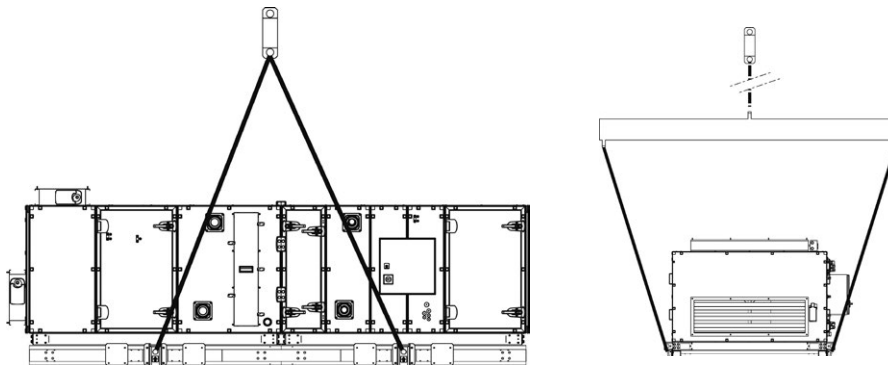

- 4 endless round slings:

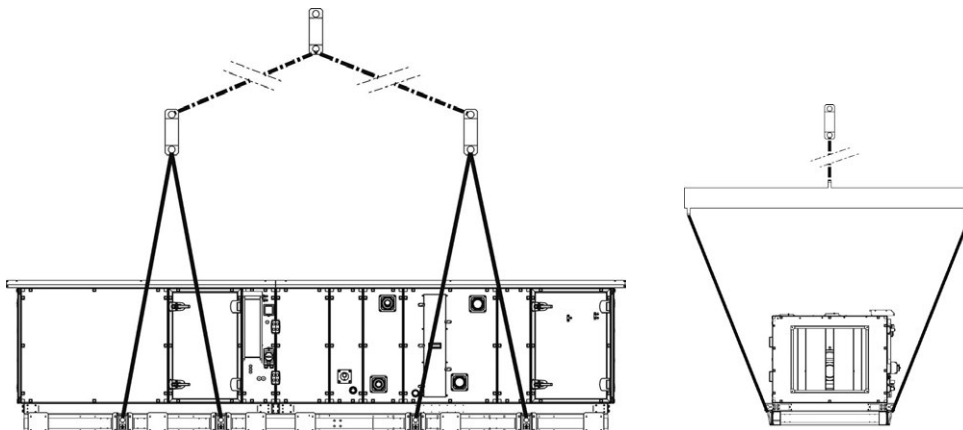

5 - SHIPPING - DELIVERY - HANDLING

5.4.1 - SPECIAL FEATURE: STACKED plate heat exchanger THE AHU B P T060 T070



- The block is transported on its side. It must be lifted onto its feet before being handled with a crane.
- There is a risk that the block could become unstable during this operation.
- We recommend that you contact a lifting professional.

1 - LIFTING the block

- Refer to the documentation: LIFTING and HANDLING Sheet 1/2.

① LIFTING

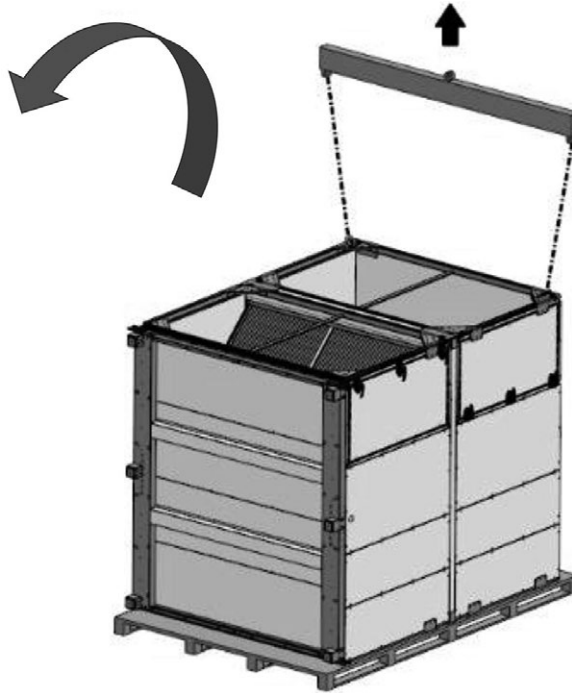

2 - HANDLING the block

- Refer to the documentation: LIFTING and HANDLING Sheet 2/2.

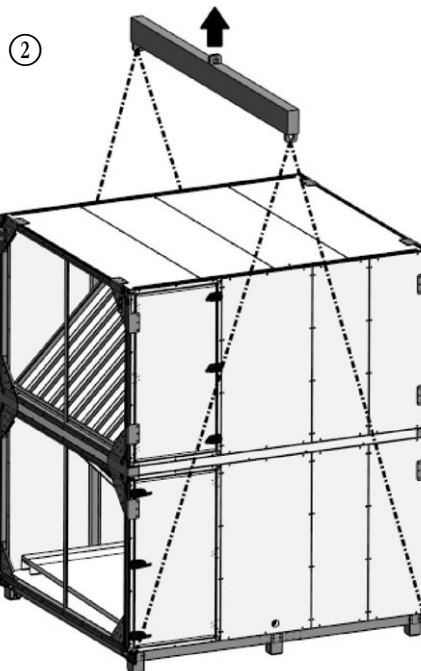

5 - SHIPPING - DELIVERY - HANDLING

5.5 - Anchoring points for handling the block fitted with transport feet

We recommend the use of shackles when handling these units.

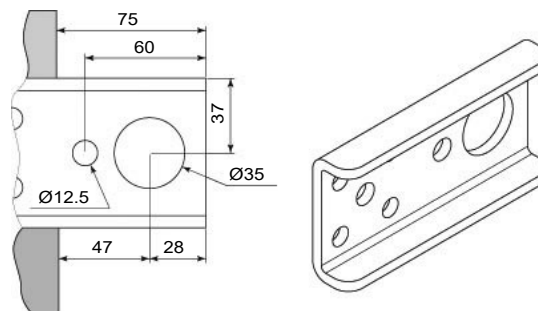
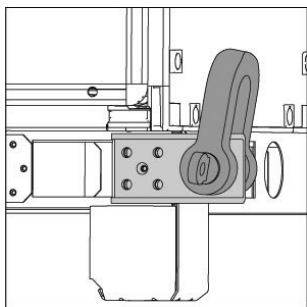

5.5.1 - Special feature of CLIMACIAT® STAINLESS STEEL

THE steel threaded brackets (red eyebolt mounting) must be removed:

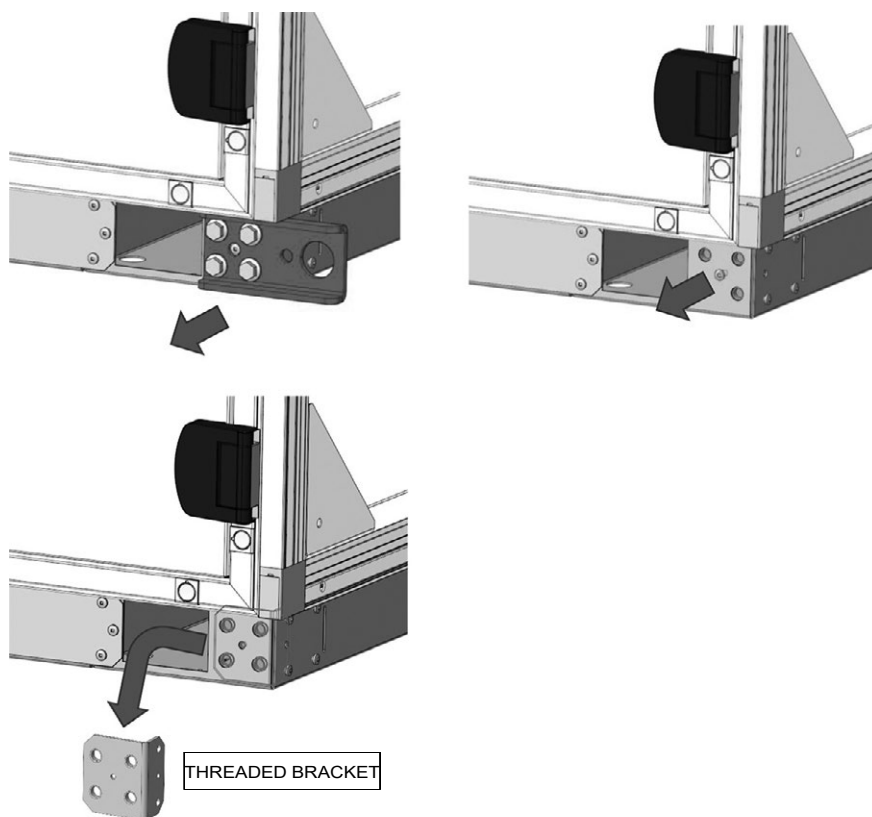

These lifting lugs are used when placing blocks near each other, AND MUST NOT BE USED ONCE DISASSEMBLED.

5 - SHIPPING - DELIVERY - HANDLING

Packaged unit on a frame:

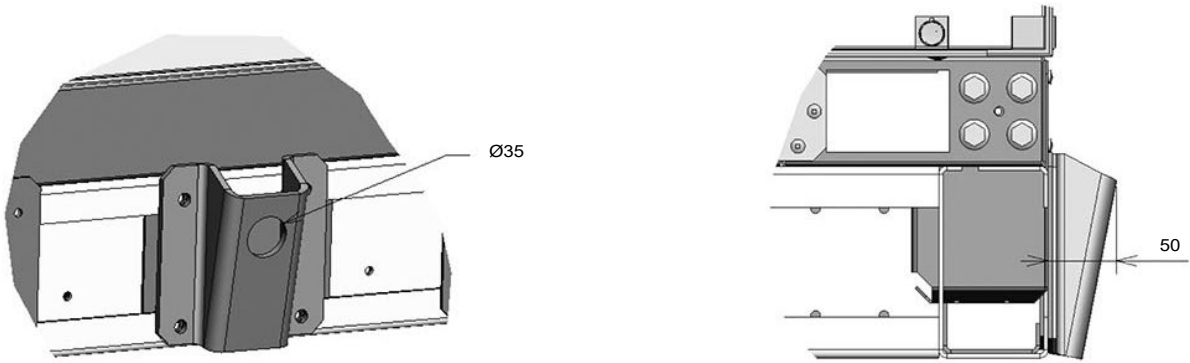

5.6 - Storage

- Do not remove the original packaging.
- Do not remove the protective caps until you are ready to connect the coils.
- The unit must be stored on a flat surface.
- Fit protection against shocks or impacts, which could damage the unit or its accessories.
- Store the blocks in their packaging, in a dry area sheltered from the weather.
- The ambient temperature must be between -10°C and 50°C.
- To facilitate the assembly of multisplit units, their components must be kept in the relevant groups. Refer to the dimensional drawings and marker labels on each block (see opposite),

ORDER NUMBER		BLOCK	
00001003		A1	
OF02376570			
DESIGNATION:			
CUSTOMER:		Packing conformity	
REFERENCE:		6	
MASS	YEAR OF MANUFACTURE		
	2016		
10			

- ① Acknowledgement of receipt number
- ② Block markings.
A1, A2, ... A9: multi-section unit.
A second unit will be marked B1, B2, ..., B9.
The numbers 1, 2 and 3 do not necessarily indicate the order of assembly (refer to the dimensional drawing),
- ③ Internal production order = The serial number should be quoted in all correspondence.
- ④ Internal designation.
- ⑤ Customer name.
- ⑥ Pre-shipment internal inspection.
- ⑦ Customer reference.
- ⑧ Weight of corresponding block.
- ⑨ Block year of manufacture.
- ⑩ Manufacturer's name and address.

6 - INSTALLATION

6.1 - Warning

The installation of equipment must comply with the regulations in force at the installation site. Before installing, make sure that the components are clean, and clean them if necessary.



Follow the safety instructions (see § 2 - SAFETY INSTRUCTIONS),

6.2 - Choise of location

■ Before setting up and connecting the unit, the installer must check the following points:



- The unit's earthquake resistance has not been verified.
 - These units can be placed directly on flat, level ground. The flatness value must be the best possible, around one per thousand.
 - For outdoor installation, take into account the regulations in force and the weather conditions at the installation site (risk of snow, height from the ground, risk of wind, etc.),
 - The selected location must not be liable to flooding.
 - Raise the unit to ensure that the unit's operation is not affected by a buildup of snow.
 - Take into account the required height of the siphon, the slope and the length of the condensate drainage container.
 - There are three support options:
 - ADJUSTABLE FEET
 - RISERS
 - RISERS + CYLINDERS (Specifications section 6.4)
 - The unit must be perfectly level (see diagram in § 6.3 Assembling the blocks),
 - The surface of the ground or structure must be strong enough to bear the unit's weight.
 - For outdoor installation with no weather protection, the unit must be equipped with the roof option. Make sure this option is fitted.
 - Leave sufficient space around and above the unit for servicing and maintenance operations (see dimensional drawing), Take into account the space required to open the doors.
 - Leave space equivalent to the total depth of the unit on the utilities side to allow internal components to be removed. See dimensional drawing.
 - Under normal indoor conditions of use, there is no need to fix the unit to the floor.
 - Under outdoor installation conditions, the unit must be fixed to the floor (windproofing),
- Depending on the regulations in force in the storage and installation location, precautions must be taken, particularly for roof installation, to ensure that the unit is stable (strong winds, earthquake, etc.), This may involve mounting on the ground or the support frame.
- For indoor installation, the room must conform to the regulations in force at the installation site. In particular, if the unit is equipped with a thermodynamic system, the room must conform to standard EN 378-3 or other specifications governing the installation location (outside EC),
 - Connections must not place mechanical stresses on the unit.
 - When connecting directly to the unit, the hydraulic pipes and air ducts must be held using supports close to their point of connection on the unit (Fig. 1),

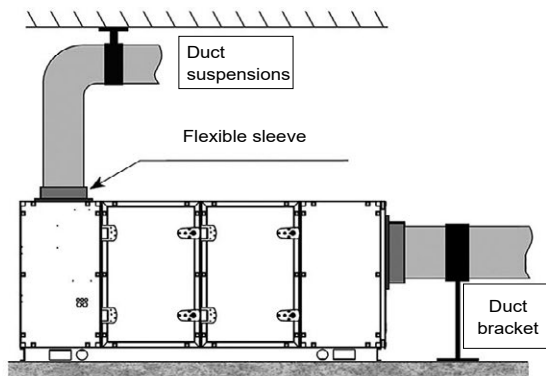
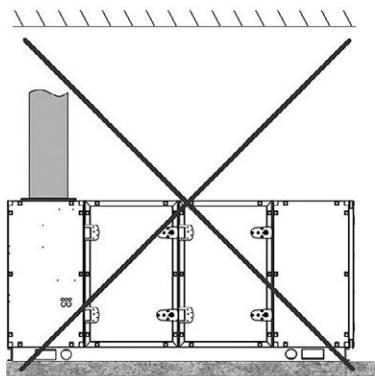

Fig. 1

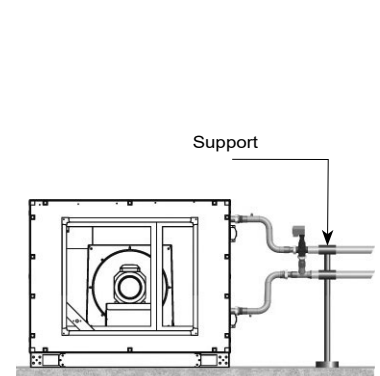

Fig. 2

- The hydraulic control valve kits must be supported close to their point of connection on the unit (Fig. 2)
 - No connection should obstruct the unit's access doors, hatches or drawers.
- Dual-flow units should be installed so as to prevent direct recirculation between the discharge and intake nozzles.
- For installation in very dusty environments or areas with high pollen levels, we recommend a system of pre-filters on the fresh air intake. The air inlets should be positioned so as to minimise adverse effects on the quality of air entering close to local emissions, such as discharge air, radon, odours or other disruptive sources (road traffic, garage doors, car parks and buses, tarmac, human impacts, animals, whether dead or alive)

6 - INSTALLATION

- Freezing fog can very quickly block the fresh air inlet filters. Fit an air preheating system (option available) for temperatures between approximately +3°C and -3°C.
- For units equipped with a gas heater (GGS or Make-Up type), the gas connection must be made by qualified personnel in accordance with the regulations in force at the installation site.

Sound level

- Our units are designed to operate quietly.
- As soon as you begin designing your system, you should take into consideration the outdoor environment to estimate the radiated noise, and the building type for the noise transmitted through the air and by solid materials.
- To minimise solid-borne vibrations, we recommend fitting anti-vibration mounts between the unit's support and frame (see diagram below), flexible connectors on the hydraulic pipes and flexible sleeves on the ducts.

Have an analysis carried out by an acoustical engineer.

For units supplied in separate elements, a counter frame must be used to add anti-vibration mounts (Fig. 1) (Frame and mounts supplied by the customer),

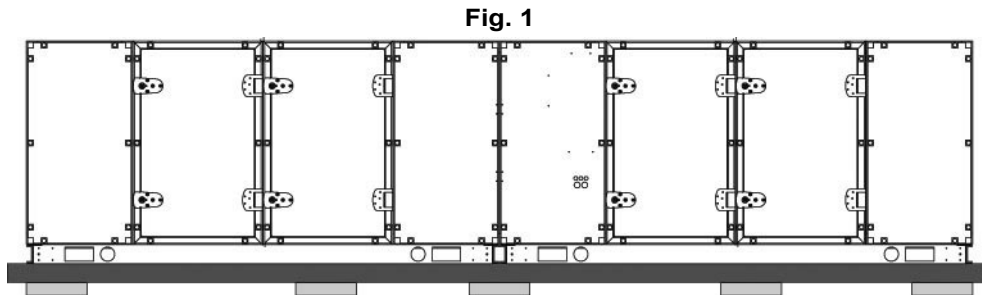

Firebreak:

Fire can spread between the supply and the return (e.g. through the heat recovery system or the mixing air), Fit the mandatory safety devices based on the regulations in force at the installation site (e.g. fire dampers),

6 - INSTALLATION

6.2.1 - INSTALLATION Stacking conditions

STACKING SINGLE-FLOW UNITS

- **IDENTICAL WIDTH:**
 - Option to stack two units of identical width: **Fig. 1**
 - ANTI-VIBRATION MOUNTS* (For a noise level study)
 - A COUNTER FRAME must be fitted*: **Fig. 2**

! Sizes 060 and 070 anti-vibration mounts **PROHIBITED**: Fig. 3

* Not supplied

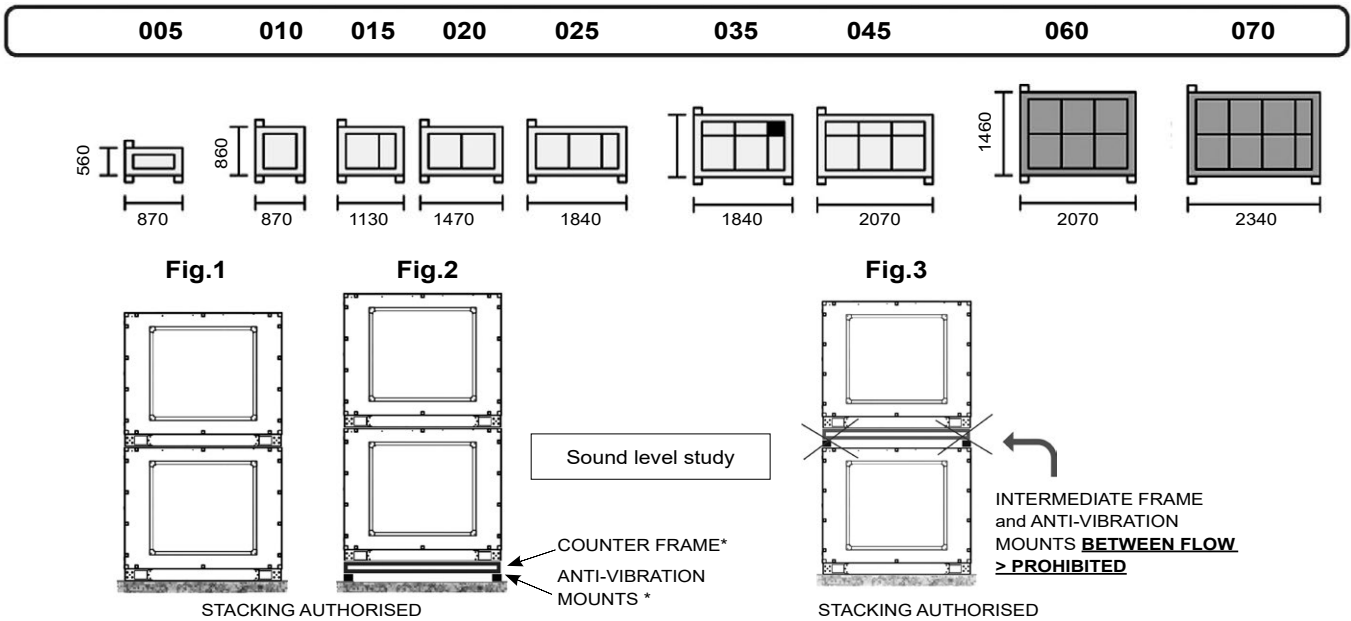

! Single-flow blocks at the top which are not fully supported on the unit must be supported by a suitable device*

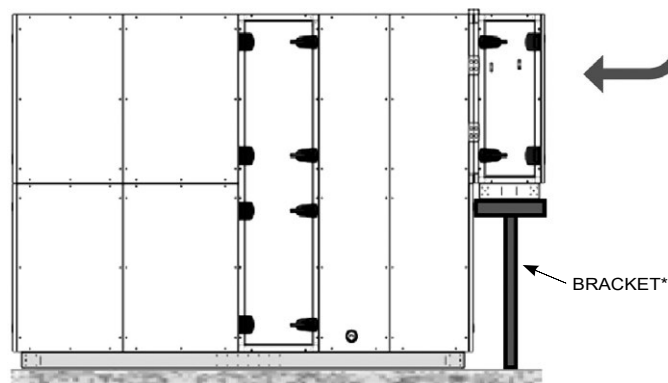

Example (identical to Fig. 2) of stacked units

Openings front view

Anti-vibration mounts and counter frame fitted to ensure uniform load distribution

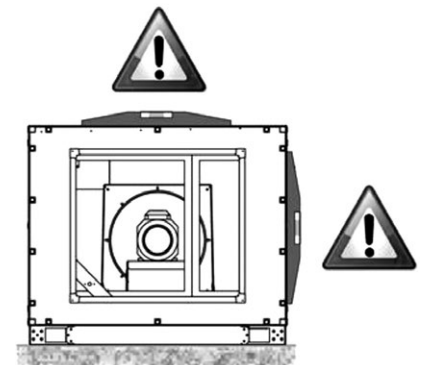
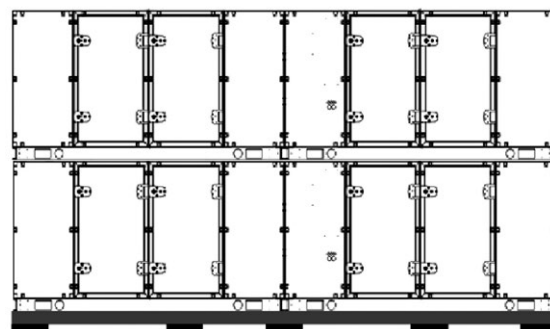

LEVELLING ESSENTIAL

To ensure correct sealing between the blocks

6 - INSTALLATION

■ DIFFERENT WIDTHS:

- To stack two units of different widths
- AN INTERMEDIATE FRAME MUST BE FITTED* of the same width as the lower unit. (Load lowering)
- * Not supplied

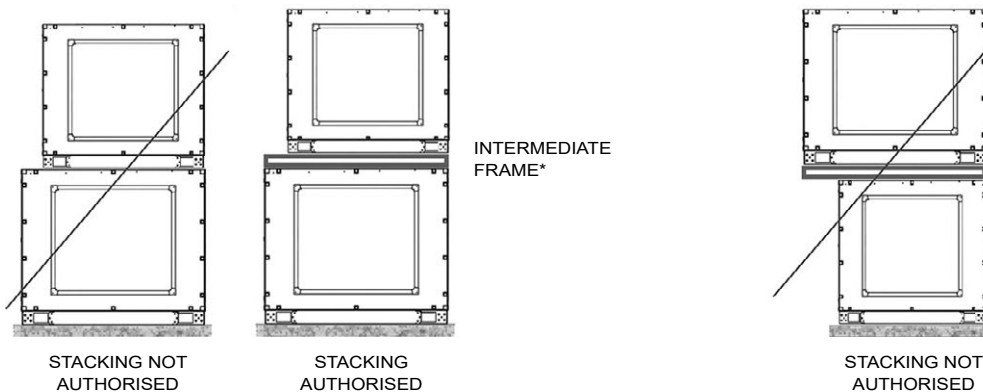

IT IS FORBIDDEN TO STACK PACKAGED DUAL-FLOW UNITS (Sizes 005 to 045)

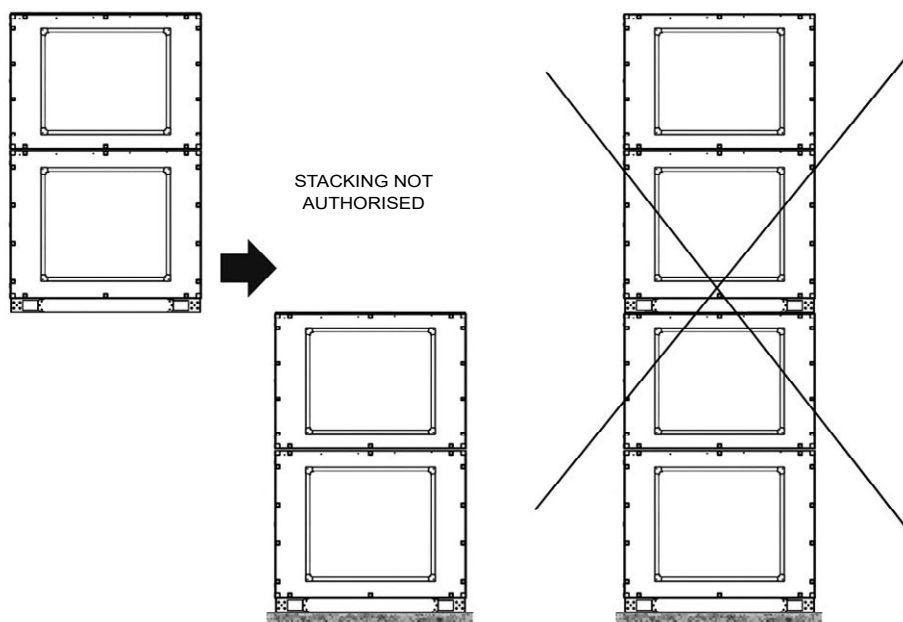
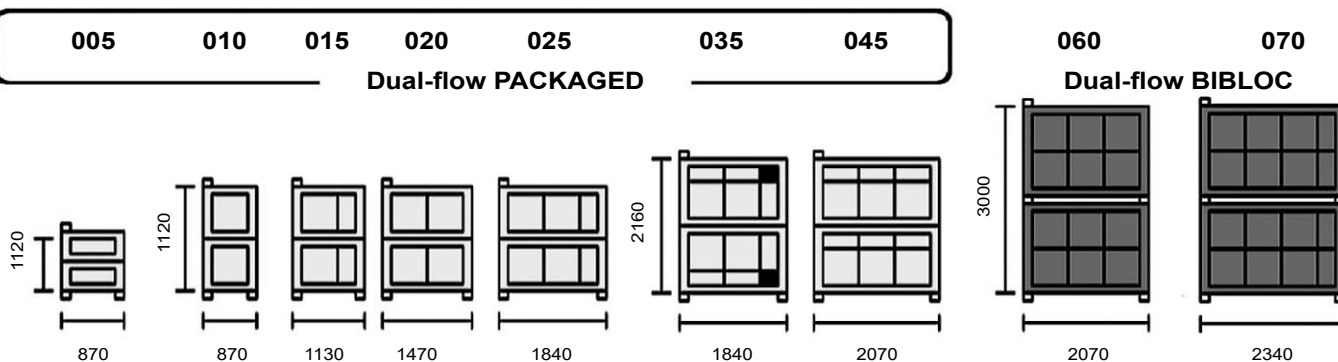

6 - INSTALLATION

6.3 - Assembling the blocks

Ensure sufficient servicing space to allow easy maintenance and assembly of the blocks.

The blocks must be assembled according to the instructions in this manual. The air inlets must be plugged if assembly is interrupted. A waterproof film is recommended to prevent white rust.



Electrical safety

The components and cables must be selected in accordance with the regulations in force at the installation site.

Always comply with the overvoltage, pollution and insulation voltage categories set by the standards and regulations.

Take into account the altitude when selecting the components and cables

Reminder: For units delivered unregulated and installed in CE zones, CE certification for the complete assembled unit is the responsibility of the person assembling it.

Make sure the ground is flat for the purposes of installing the unit and connecting the blocks.

To ensure a tight seal between joined sections, they must be shimmed and levelled to compensate for any unevenness of the mounting surface.

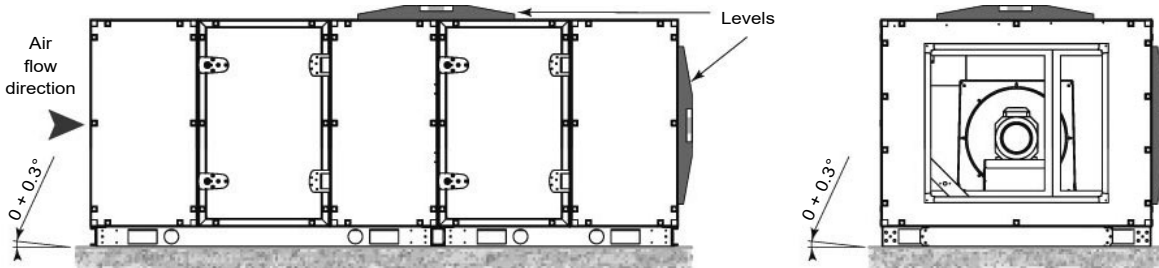

The unit must be grounded via its frame. Make sure all electric components are grounded.

- The units are supplied with transport feet (1).

They must be removed and possibly replaced with adjustable feet or risers before final assembly. (see § 6.4),

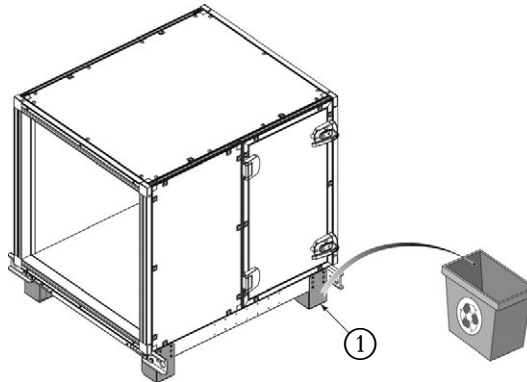

- Affix the cleats (2) supplied in the connection kit (fig.A) in the dedicated holes using long screws 4.8 x 40 mm (5) in each block.

Fig. A

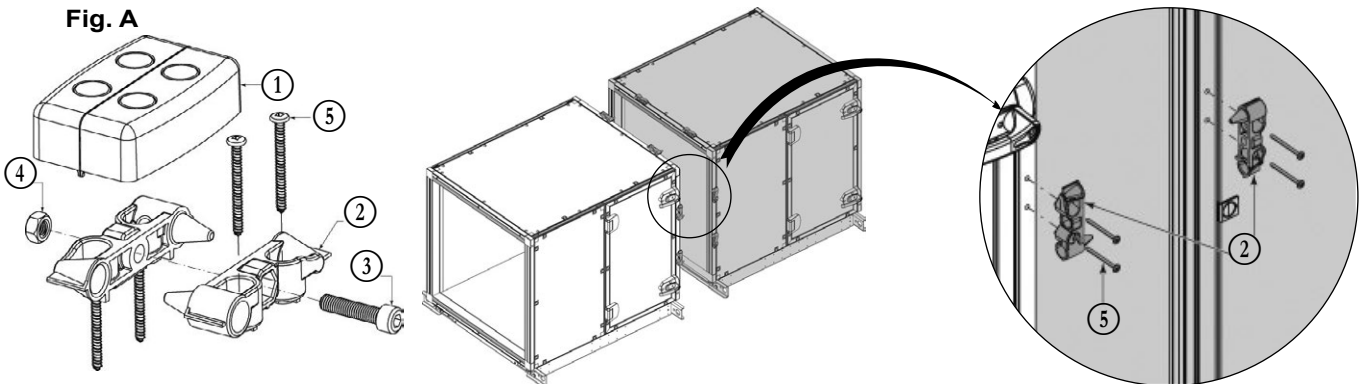

6 - INSTALLATION

- Fit the 15 x 9 gasket on the end partition of one block. To ensure a proper seal between two blocks, position the gasket on the aluminium profiled edge of one block as close as possible to the inside of the unit (illustrations below),

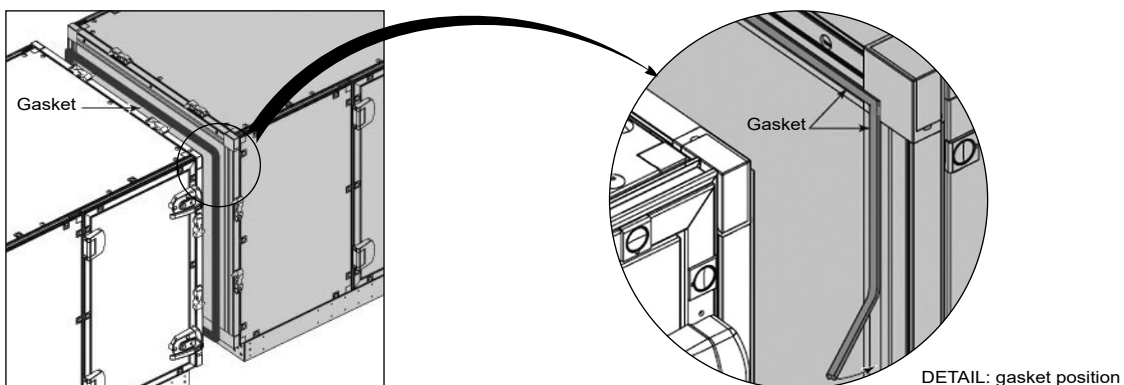

6.3.1 - Gasket removal procedure:

- To ensure proper sealing, the gasket must be fitted as a single piece.
- The connection must be at the bottom, ideally in the centre, but not in a corner.
- To guarantee optimal long-term integrity, the gasket must not be removed when taut.
- Likewise in the corners, it must not be taut, but should form a rim inside the corner.

Sketch below:

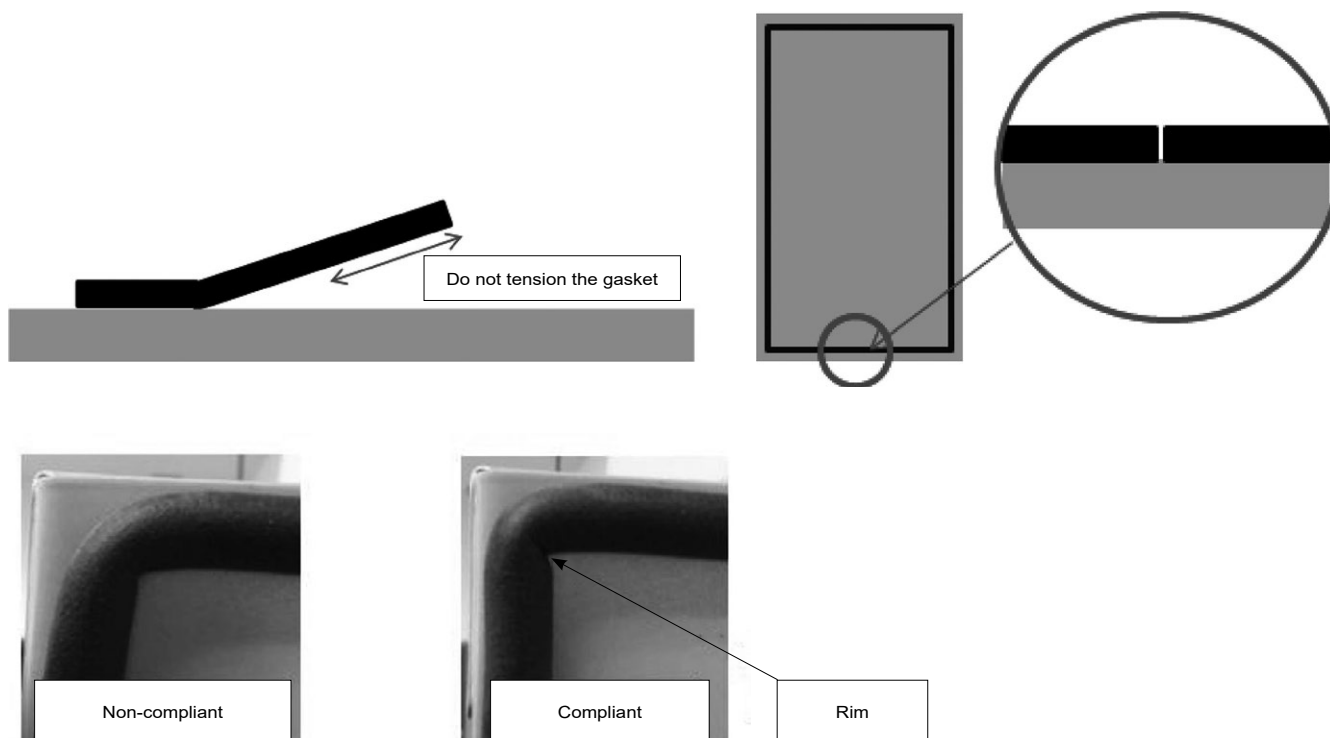

6 - INSTALLATION

■ AHU with option T2-TB2.

An additional 15 x 9 sealing gasket must be fitted to the same block, as close as possible to the outside of the unit. (see figures below),

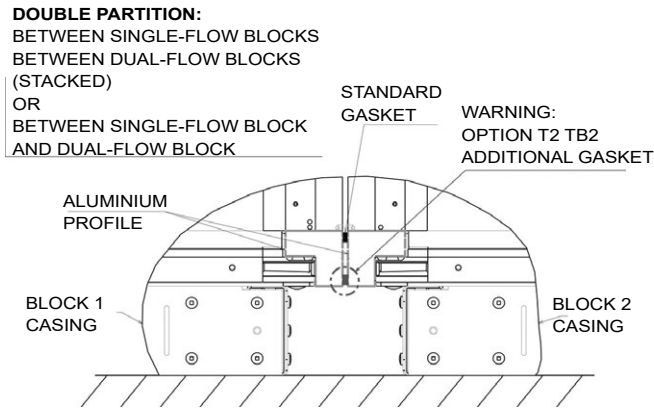
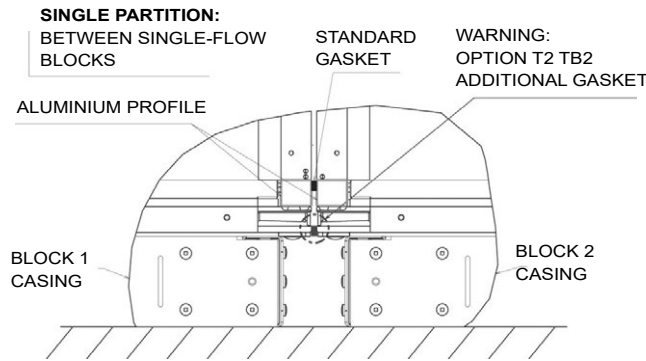

■ If the AHU has a control option.



Before the blocks are definitively brought together, the cables must be fed into the lower raceway (frame),

SINGLE FLOW AHU	DUAL-FLOW AHU
1. Unwind the cables from the ends (the cables are prewound in the factory)	1. Unwind the cables from the ends (the cables are prewound in the factory)
	2. Route the cables into the lower frame and to the vertical raceway
	3. Place the cables in the raceway
4. Feed the cables through the upper raceway	4. Feed the cables through the upper raceway
5. Route downwards into the unit	5. Route downwards into the unit

■ Remove the lifting lugs and use a strap to bring the blocks together, taking care not to damage the front panel components.

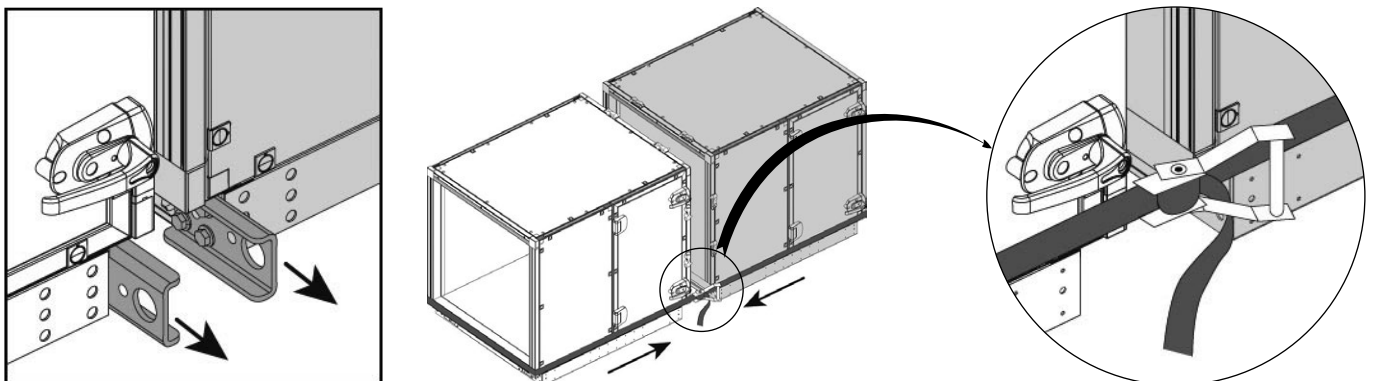

6 - INSTALLATION

Accessories for bringing the blocks together

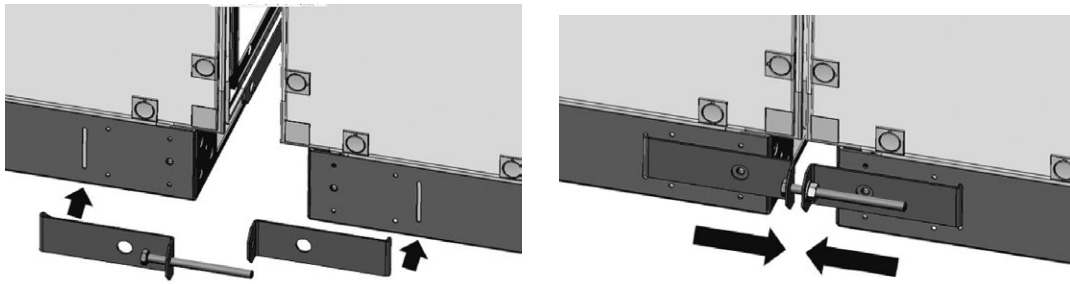

To finish bringing the blocks together, 4 brackets are provided to be used simultaneously: 2 on the FRONT FACE and 2 on the REAR FACE. (figures 1 and 2 below),

When bringing the blocks together, make sure the various cleats (2) fit together correctly.

Finalise the assembly by screwing the connecting cleats together using the metric screw (3) + M8 nut (4) supplied in the kit.

- Clip the covers onto the cleats (1),

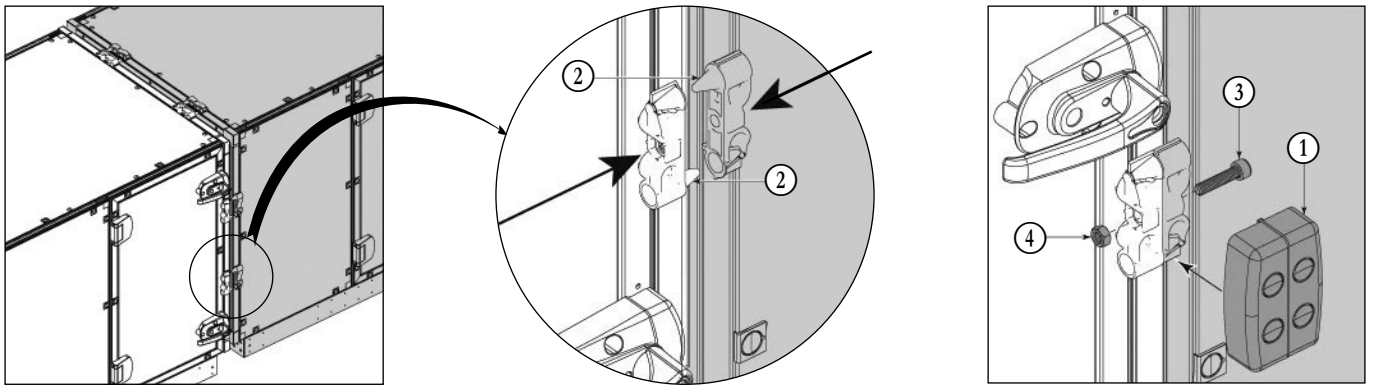

Assembling the mixing option in 2 self-contained blocks.

- Fit a gasket on the 2 bearing faces of the insulated sleeve (sleeve supplied in the AHU),
- Affix the sleeve to the outside of the AHU against the mixing damper (4.8 x 19 sheet metal screw),
- Bring together the 2 blocks.
- Connect the sleeve to the 2nd block from the inside of the unit.
- Affix the panel to prevent access to the sleeve connection (4.8 x 19 sheet metal screw),

6.3.2 - SPECIAL JUXTAPOSE FUNCTION

Assembly procedure for the AHU system blocks adjoining the adjacent blocks:

- The brackets (1) are preassembled on the large block for the adjacent function.
- The brackets (2) with bolts (bottom) must be assembled on the blocks which connect to the adjacent blocks (pre-drilled holes),
- To assemble the "satellite" blocks, use **four 4.2 x 19 mm screws** to fit each block.

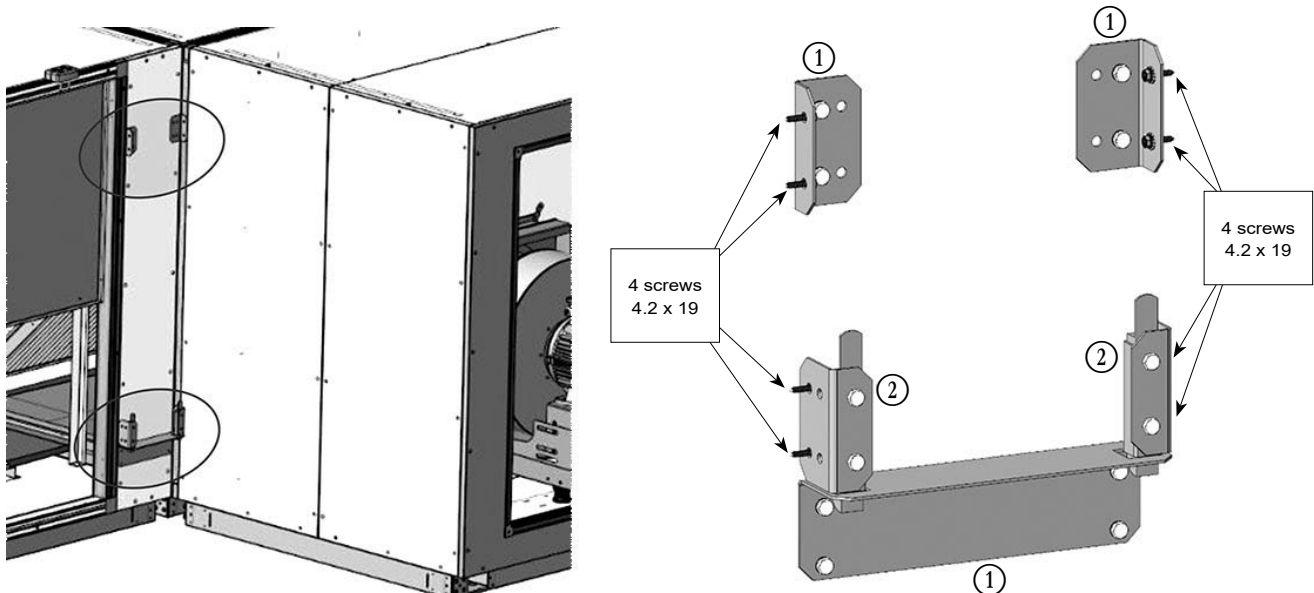

6 - INSTALLATION

6.4 - OPTIONS: Adjustable feet, risers and risers + cylinders

Description	Instructions
ADJUSTABLE FEET (cylinder with foot which is articulated and adjustable over 30 mm) MIN. = HT 113 mm/MAX. = HT 145 mm	<ol style="list-style-type: none"> 1. Remove the transport feet 2. Screw in the cylinders under the adjustable feet 3. Fit the adjustable feet with the M8 screws included in the transport feet positions 4. Use the cylinders to adjust the levelness
RISERS HT200mm, HT300mm, HT400mm	<ol style="list-style-type: none"> 1. Remove the transport feet 2. Fit the risers with the M8 screws included in the transport feet positions
RISERS + CYLINDERS (cylinder with foot which is articulated and adjustable over 30 mm) MIN. = HT 263 mm/MAX. = HT 290 mm MIN. = HT 363 mm/MAX. = HT 390 mm MIN. = HT 463 mm/MAX. = HT 490 mm	<ol style="list-style-type: none"> 1. Remove the transport feet 2. Screw in the cylinders under the risers 3. Fit the risers + cylinders with the M8 screws included in the transport feet positions 4. Use the cylinders to adjust the levelness

ADJUSTABLE FEET OPTION

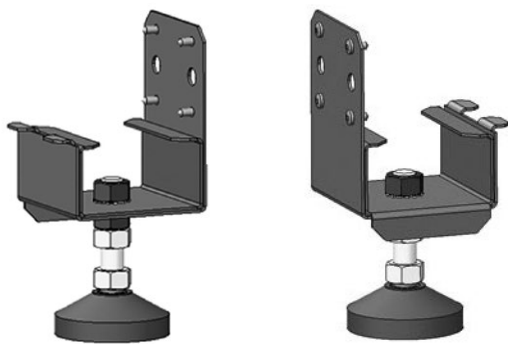

ADJUSTABLE FOOT
MIN. HEIGHT

ADJUSTABLE FOOT
MAX. HEIGHT

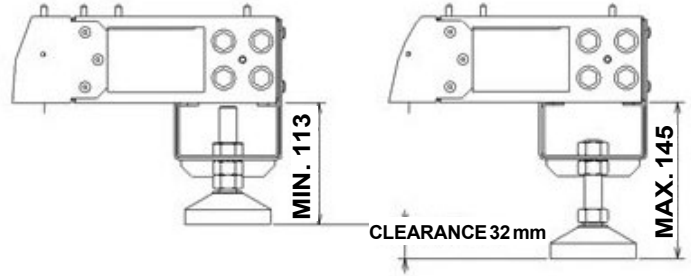

RISERS OPTION

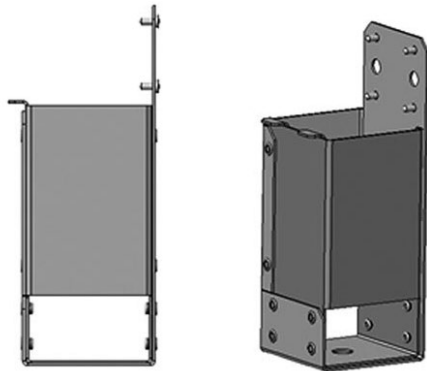

3 SIZES: 200 mm 300 mm 400 mm

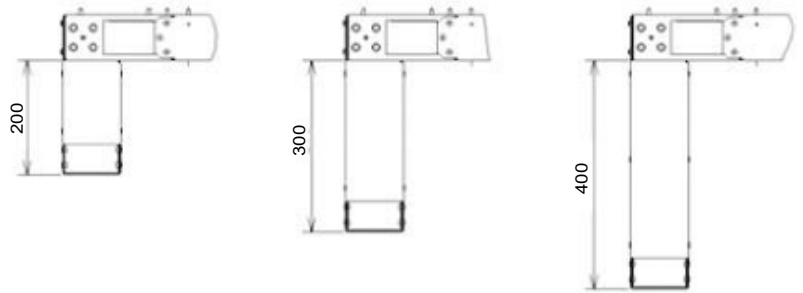

RISER FEET AND + STRUTS OPTION (ARTICULATED FEET)

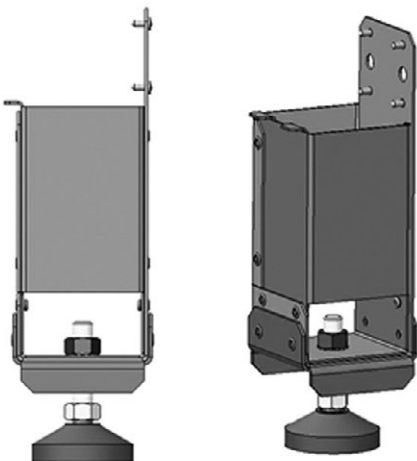

3 SIZES: 200 mm 300 mm 400 mm adjustable over 29 mm

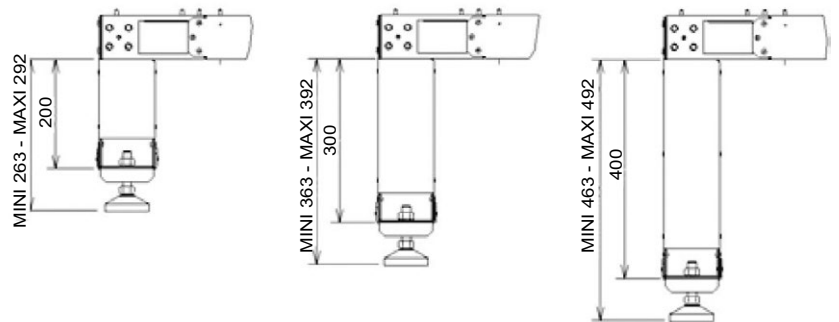

6 - INSTALLATION

6.5 - JUXTAPOSE FUNCTION sealed junction special features

- !** For a unit with the side-by-side plate heat exchanger function;
ASSEMBLY MUST START WITH THE TWO BLOCKS OF THE SIDE-BY-SIDE PLATE HEAT EXCHANGER FUNCTION.
The other blocks which make up the system will be assembled afterwards.

Connecting the blocks:

To guarantee the tightness between the flows. Apply a PVC seal to one of the two blocks before bringing together and assembling.

- 1 - Position of the gasket: on the leakage partition wall returns
- 2 - Bringing together
- 3 - Internal attachment points, between blocks > 8 mm D bolts X 6

1

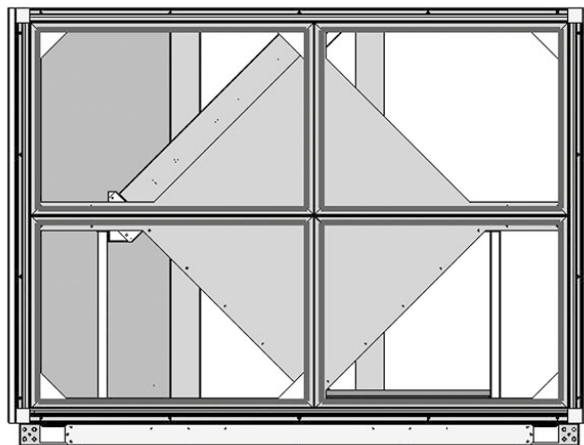

2

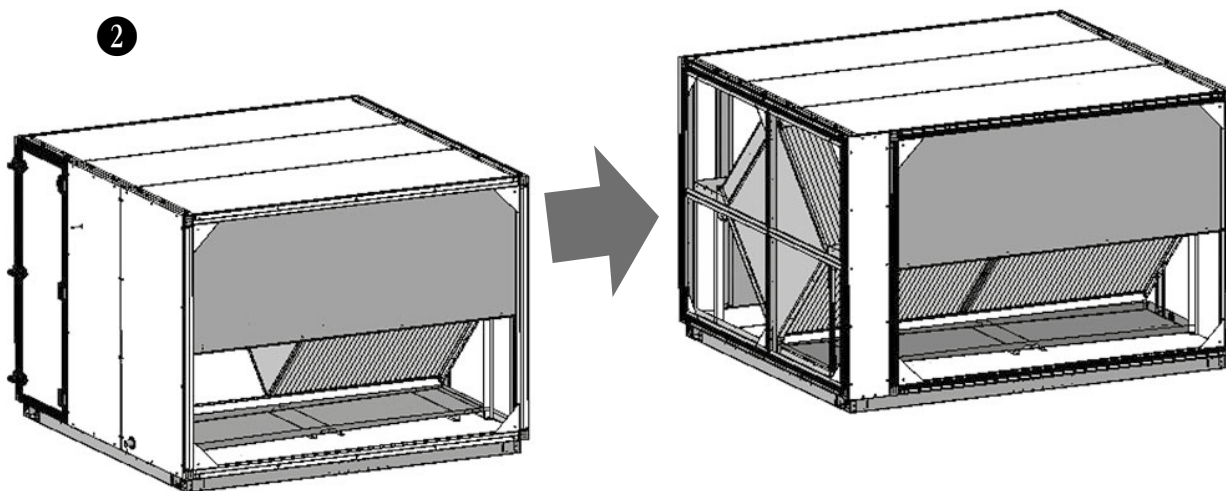

3

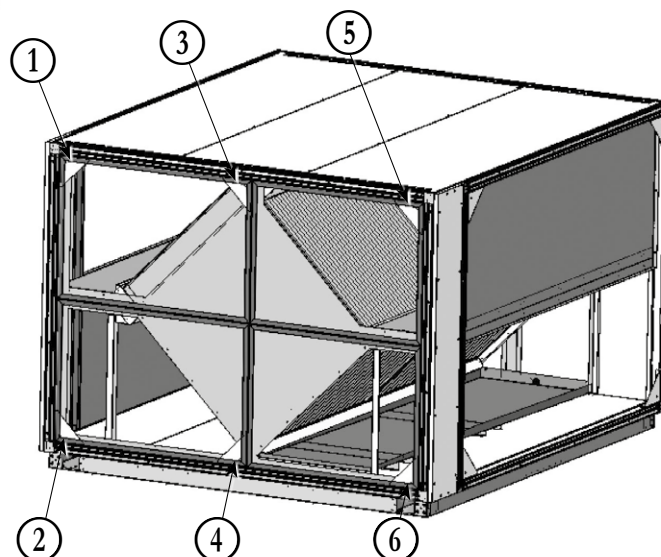

6 - INSTALLATION

6.6 - Roof/canopy (Accessories)

Depending on the sizes and the options, the roof and canopy may be delivered on a pallet, or attached to one of the blocks (roof) or fitted in position (canopy),



A roof supplied attached to a transport bracket on the front must be unpacked as shown in fig 1-2-3

Roofs packaged in plastic film

Fig 1

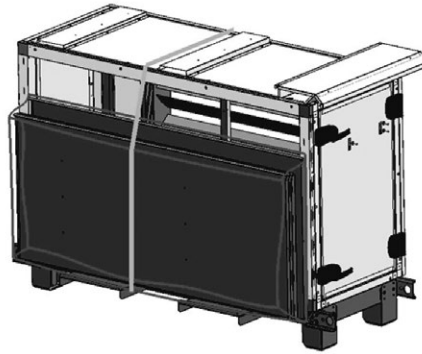

When unpacking, take care when cutting the strapping encircling the roofs; it is recommended that two people perform this operation

Fig 2

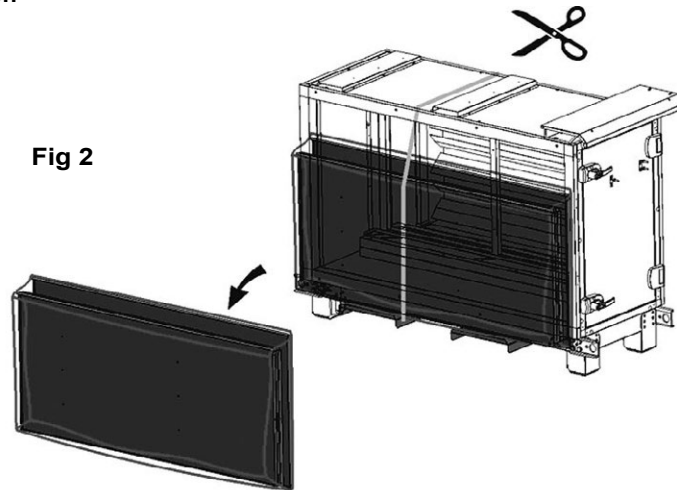

Disassembly of the roof support or supports using a tool with an SR2 fitting

Fig 3

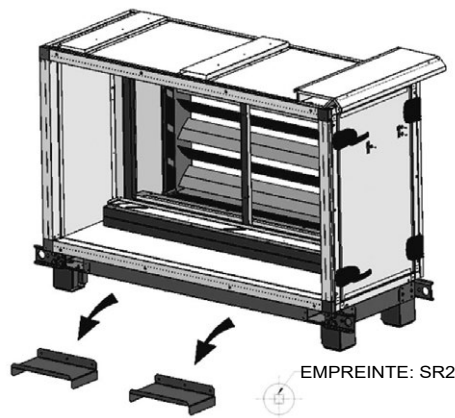

Roof assembly:

- A Remove the cover(s) from the raceway.
- B Fit the left- and right-hand blanking covers at the top of the end panels using the screws supplied in the installation kit.
- C Fit the 2 gaskets lengthways along the raceway.
- D Fit the gasket on the side of each roof panel (V-shaped fold) and on the left-hand blanking cover (V-shaped fold),
- E Also fit the gasket with the V-shaped fold on the blanking cover and on the raceway connecting cover (only present on blocks longer than 2800 mm)
- F Fit the roof panels in the order shown on the plan supplied with unit.
- G Affix the panels to the raceway (from inside the raceway); secure them together and on the omega brackets using the screws provided (screws+sealed washers)
- H Fit the covers back on the raceway. Check that a 15x3 gasket is glued to the ends of these covers. Affix them with the screws provided.

6 - INSTALLATION

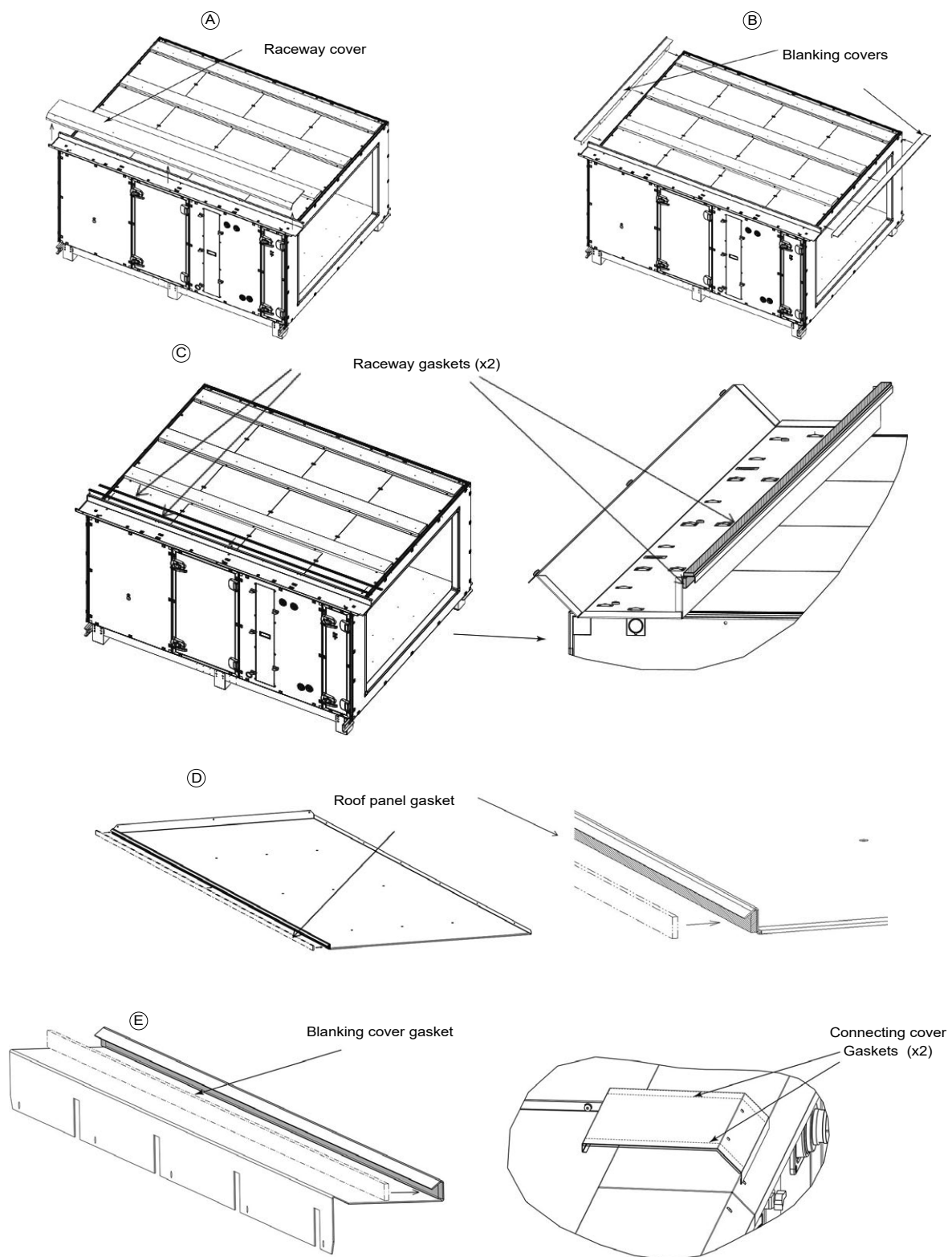

6 - INSTALLATION

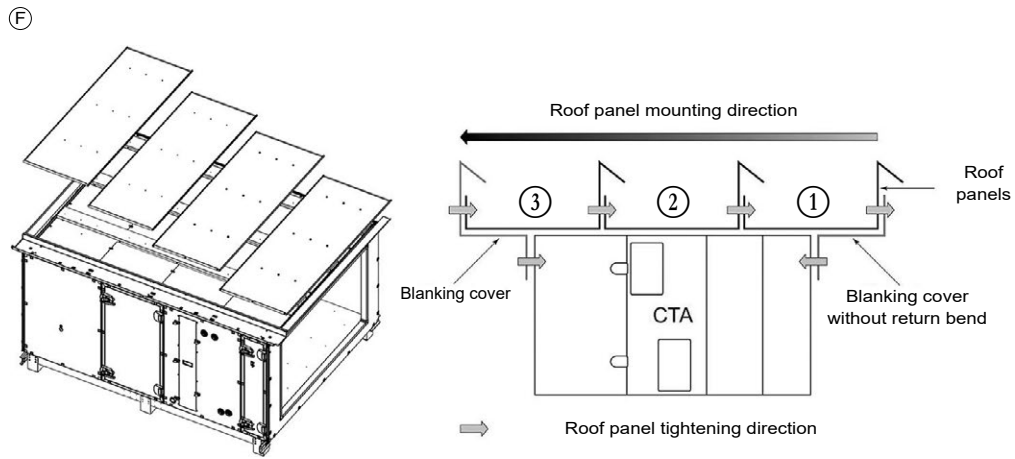

DO NOT CLIMB ONTO THE ROOF PANELS

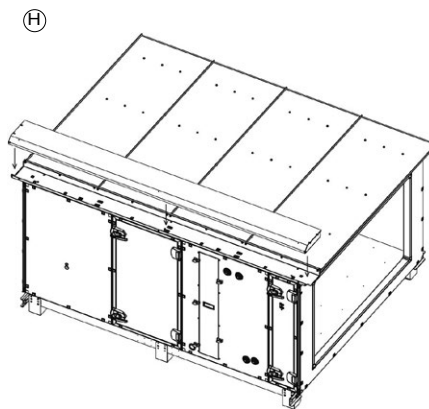
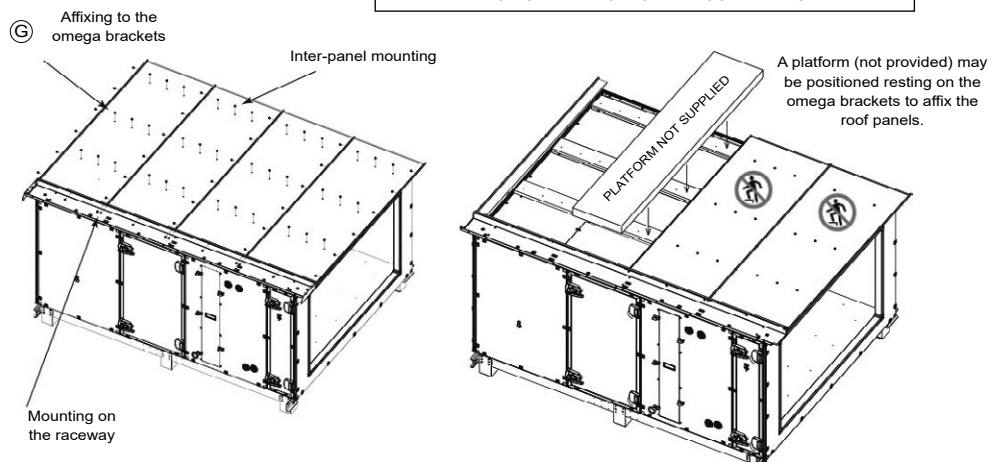

6 - INSTALLATION

JUXTAPOSE T060 - T070 FUNCTION SPECIAL FEATURE

ASSEMBLY PROCEDURE for the ELECTRICAL CHANNEL (WITH or WITHOUT CONTROL UNIT)

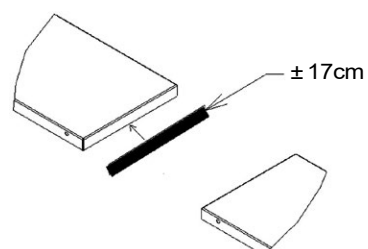
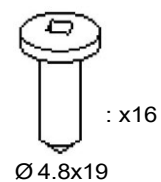
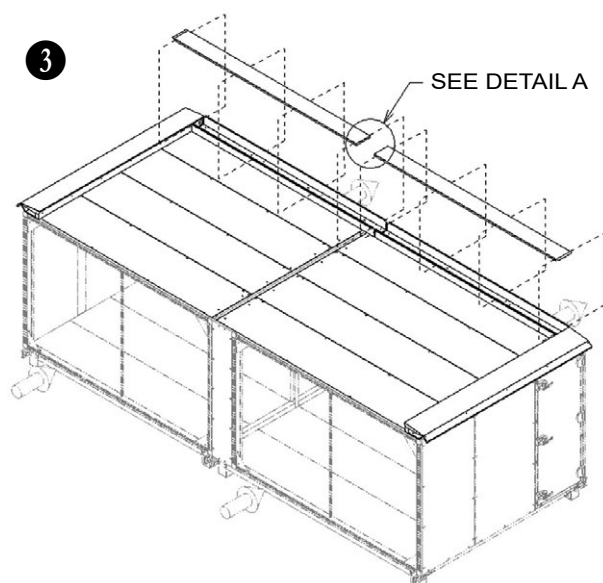
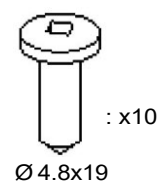
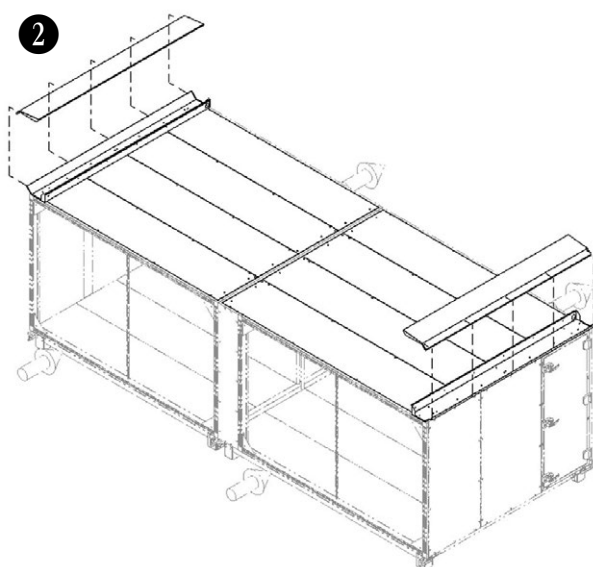
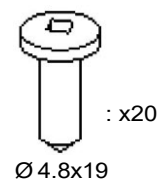
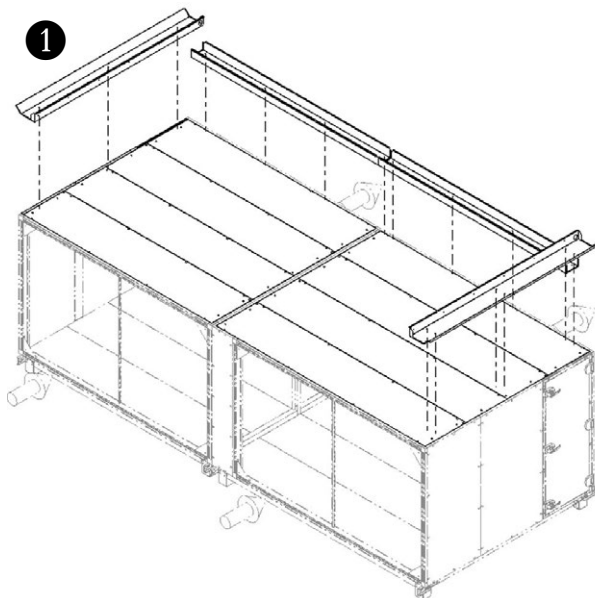

DETAIL A
SCALE 0.1

6 - INSTALLATION

ROOF : Assembly procedure :

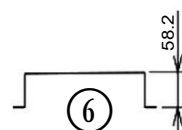
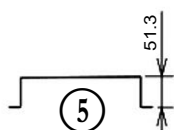
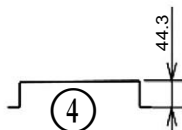
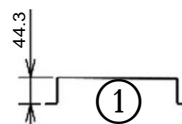
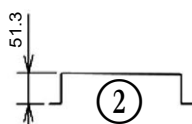
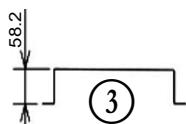
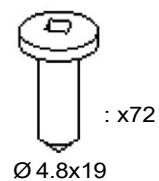
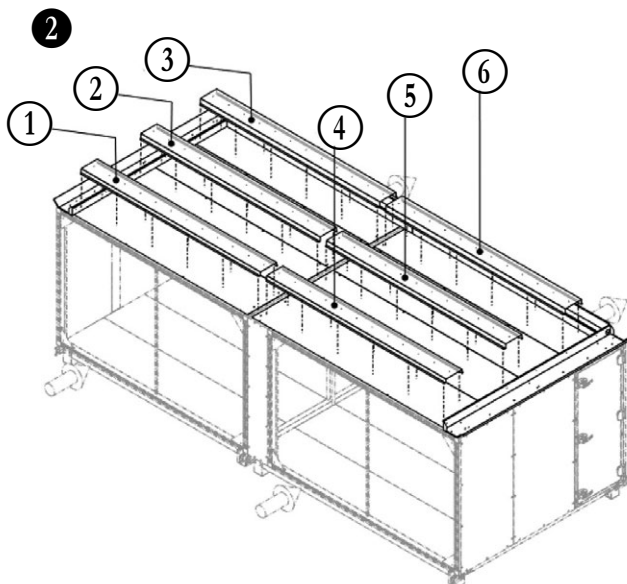
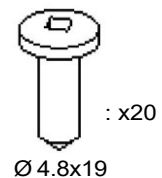
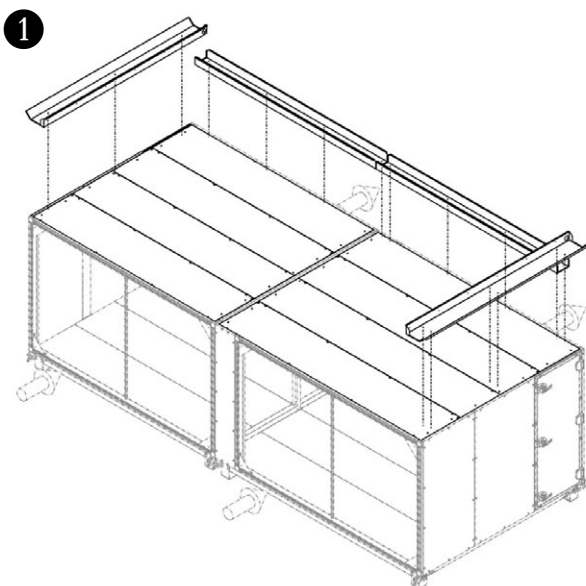

6 - INSTALLATION

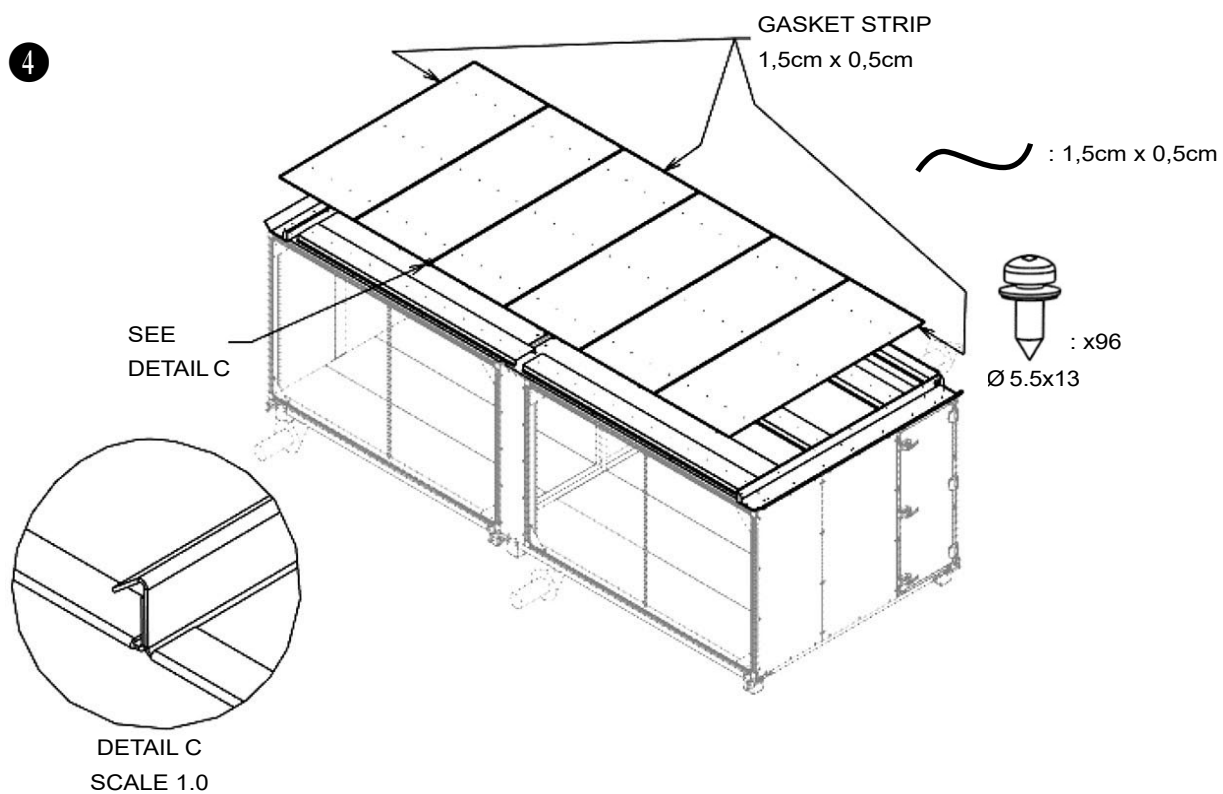
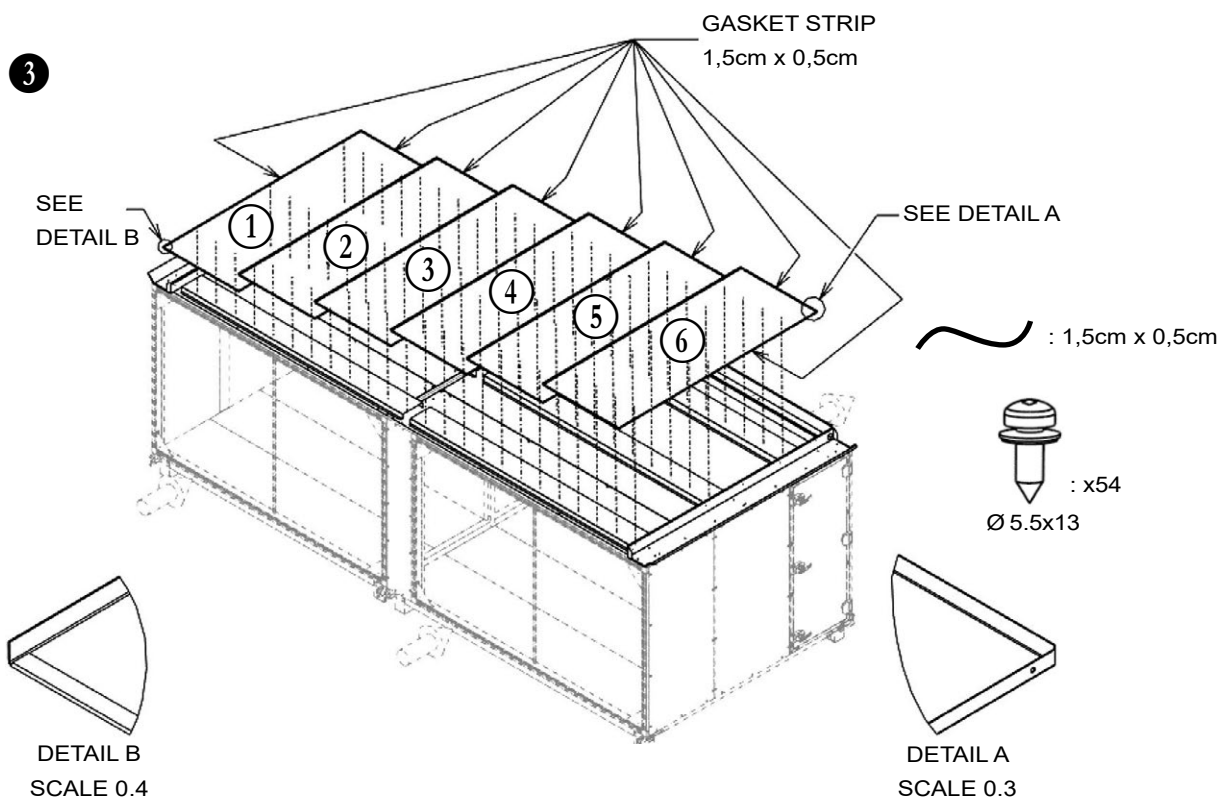

6 - INSTALLATION

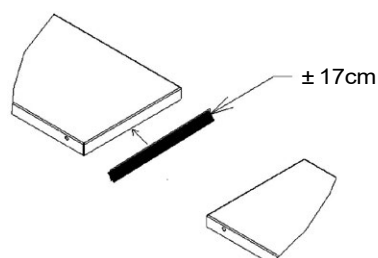
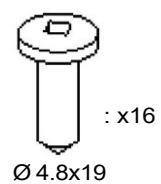
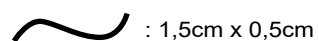
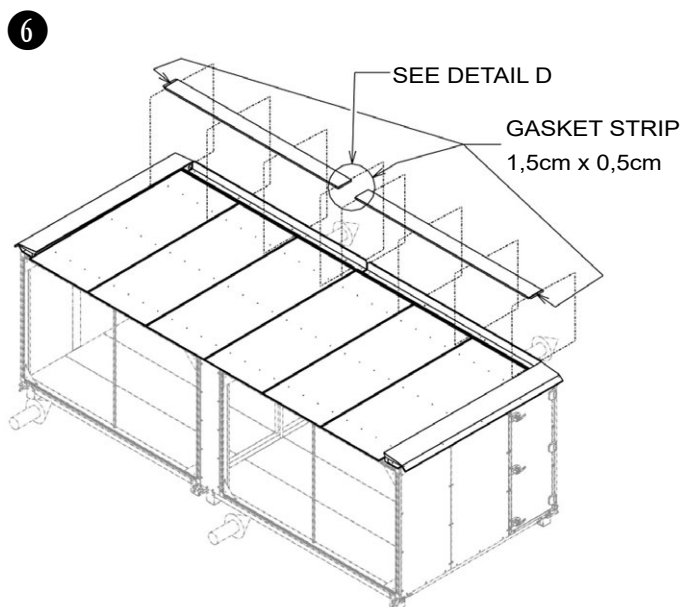
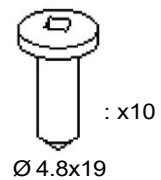
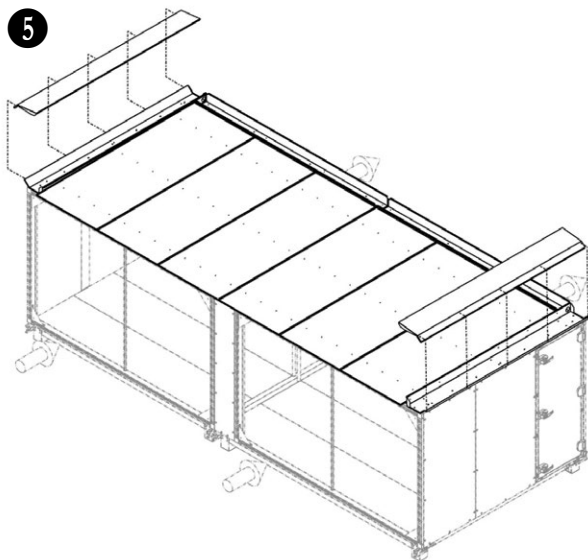

DETAIL D
SCALE 0.1

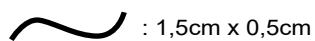
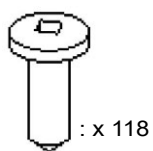
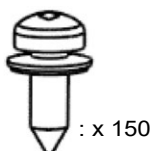

7 - CONNECTIONS

7.1 - Condensate drain siphon

- Connecting the siphon

Position, diameter and type of connector, see dimensional drawing.

Outlet on the front panel: Threaded gas type steel connector.

Outlet in frame: Smooth rubber female sleeve for 32 mm PVC bonding tube.

It is recommended to use mastic to adhere the drain pan.



The siphons and drain pipes must be insulated and protected from frost (heating cable),



The siphons must not be directly connected to the waste water network.

- Siphon calculation:

$$H \text{ in mm} = Pa / 10$$

Pa = Pressure difference (in Pascal) between the inside and outside of the unit.

- Assembly with depression :

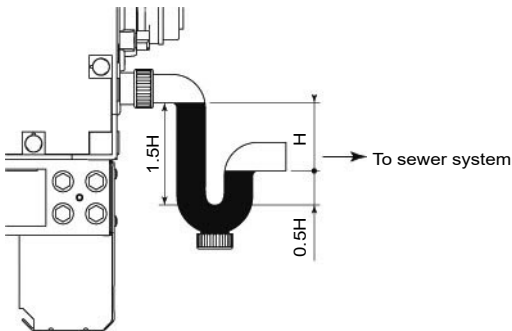

- Assembly with pressure:

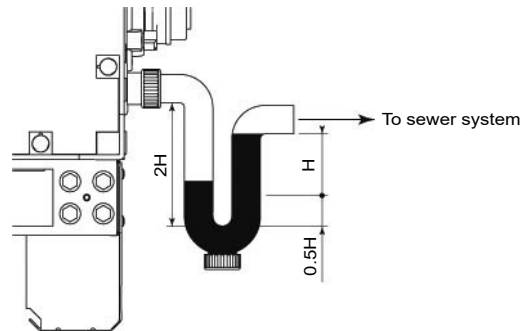

- Assembly with several coils in parallel:

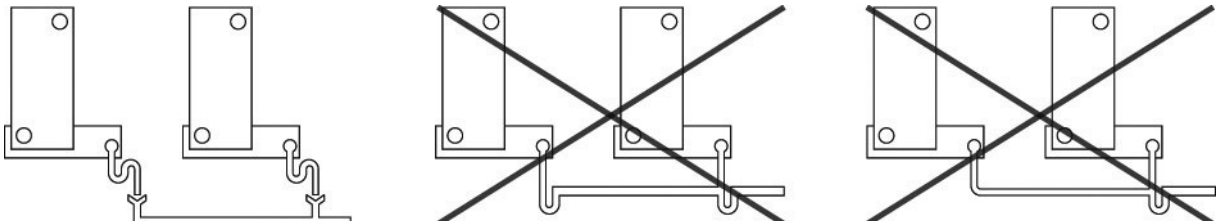

7.2 - JUXTAPOSE function SPECIAL FEATURE.

- Dual condensate drain = 1 siphon per front face.

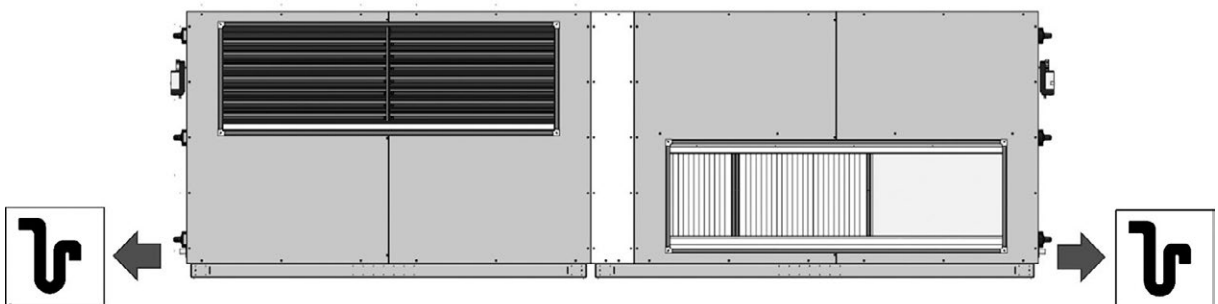

7.2.1 - Heating/cooling coil

7.2.1.1 - Supplying the coils

Follow the instructions on the labels:

Observe the counter-flow principle

- Fluid inlet downstream of the air flow direction
- Fluid outlet upstream of the air flow direction

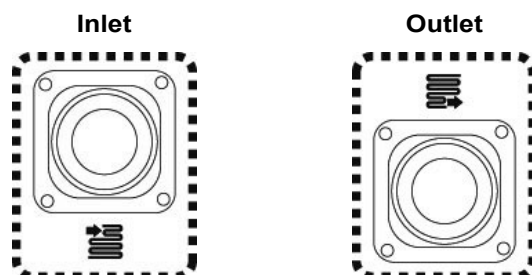

7 - CONNECTIONS

7.2.2 - STEAM coil

7.2.2.1 - Coil supply:

- Follow the instructions on the labels:

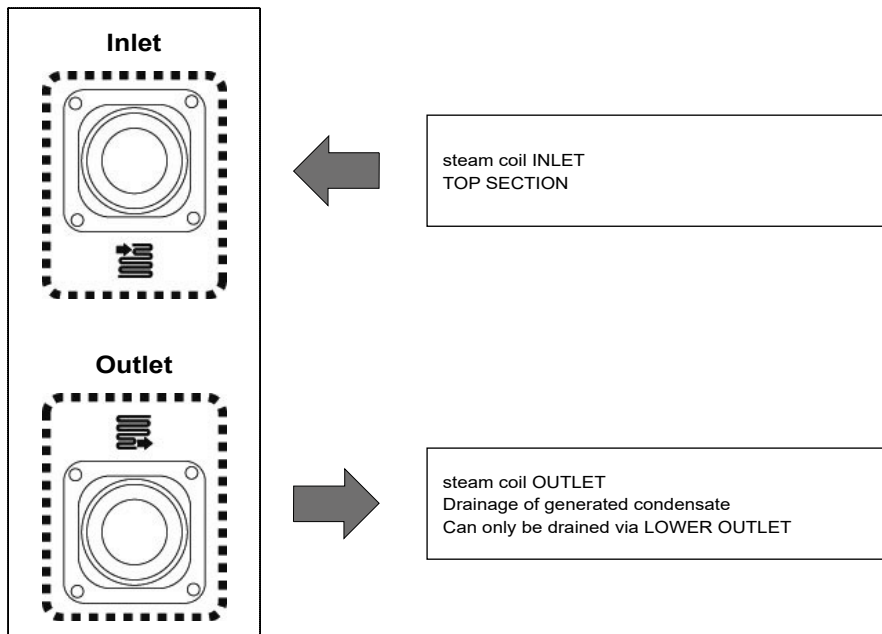

7.2.3 - Connection

- Refer to your dimensional drawing for the diameters of the connections and their positions.
- Before connecting, make sure the inside of the hydraulic system pipes is perfectly clean and free from debris or deposits.
- The pipe routing and insulation must not obstruct the removal of the heat exchanger for replacement or maintenance. Use removable connectors and insulation components (valves),
- The system pipes must be affixed to the walls, ceiling or floor of the building, and must under no circumstances exert an additional load on the unit. Make sure the pipes are supported.
- The pipes must not transmit any thermal or vibrational stress to the heat exchanger. Use expansion sleeves. Do not use galvanised connectors. Check the material compatibility (risk of electrolysis),
- The pipes must be insulated to prevent condensation and heat loss.



Make sure the insulation is no thicker than 40 mm to leave enough space to open the doors or removable panels.

- Connecting the condensate drainage: See § 7.1 "Condensate drain siphons",

7.3 - Droplet eliminator

The pipe routing and insulation must not obstruct access or clearance for the slide of the antifreeze thermostat and/or droplet eliminator (shaded area),

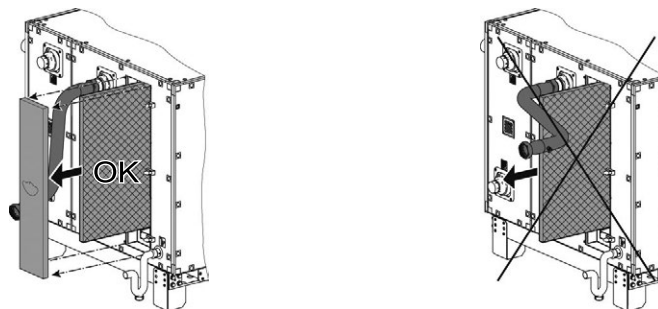

7 - CONNECTIONS

Connection types:

- Heat exchangers with cylindrical threaded connectors with flat gaskets.

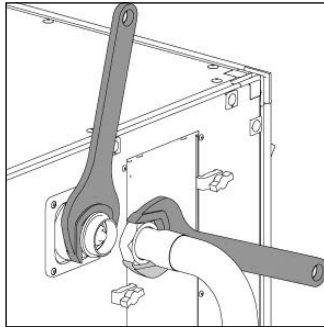

- Always use two spanners when connecting or tightening the hydraulic couplings to avoid twisting the pipes and applying stress on the brazed areas.
- **Do not use zinc-coated or galvanised connectors or pipes.**



Check the compatibility of the materials (risk of electrolysis),

- Heat exchangers with threaded connectors. Screw flange or Victaulic type grooved connector adaptor kits are available

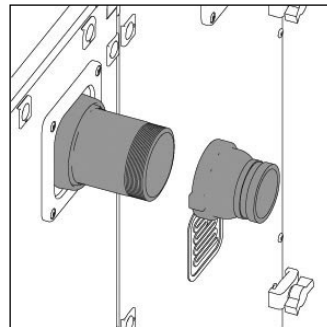
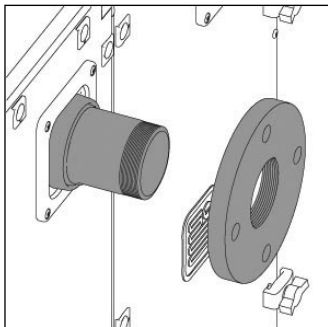

- Heat exchangers with "Victaulic" type grooved connectors.
- Follow the instructions from the connector manufacturer when preparing and aligning the pipes.
- **Do not use zinc-coated or galvanised connectors or pipes.**



Check the compatibility of the materials (risk of electrolysis),

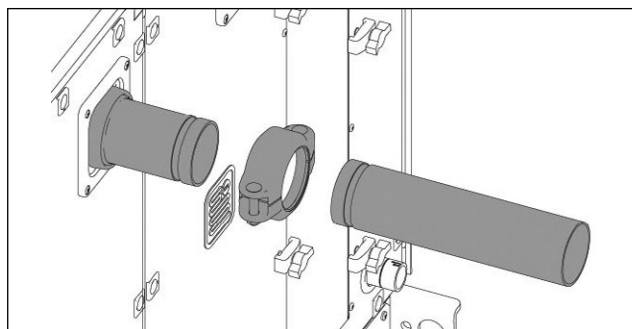

- Heat exchangers with grooved connectors. Optional threaded connector or flange adaptor kits are available.

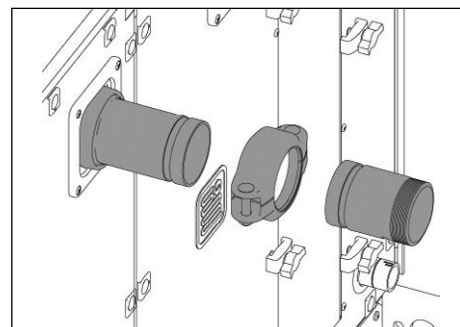
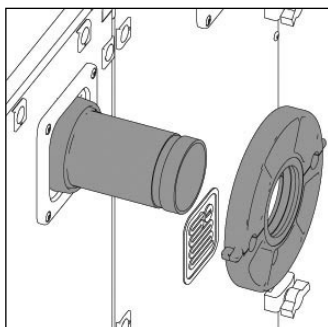

7 - CONNECTIONS

- Exchangers with smooth braze-type INLET/OUTLET pipes.



WARNING: Be careful not to damage the bellows when brazing

- 1/ Damp cloth
- 2/ Brazing time < 10 seconds.

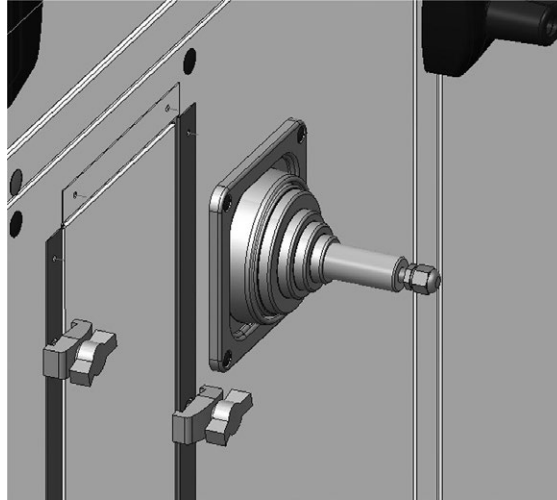

7.3.1 - Fitting the control valves (optional)

Carry out installation in accordance with the plan supplied with the kit.

The pipes and valves must not under any circumstances place any additional load on the unit. The pipes must be supported on the wall or floor of the building.

The valve motors must have frost protection if they are likely to be subjected to temperatures below -10°C (motor environment), For valves installed outdoors, provide an enclosure for the motors to protect them from the weather.

7.3.2 - Bleeding, draining, filling

In accordance with industry practice, provide a bleed hole at the high point and a draining and filling hole at the low point for each hydraulic circuit.

It is recommended to use a filling device with a check valve.

To comply with anti-pollution standard NF EN1717 or the regulations in force at the installation location. The device must under no circumstances be connected to the municipal water supply unless the additives used in the hydraulic circuit have been approved by the ministry of health (e.g. monopropylene glycol (MPG) products with NEUTRAGEL SANIT or HELIOGEL CS 80 approval),

7.4 - Electric heater

Risk of fire and unit damage if the air flow is absent or too low:



REQUIRED MINIMUM AIR SPEED : 0.8m/s

- Use an air flow control device set in accordance with the dissipated heating power,
- The operation of the heating coil must be fan-controlled.
- A fan delay of at least 15 minutes must be applied after the electric heater has been switched off,
- In variable flow operation, power staging is recommended for the electric elements (multi-stage or TRIAC) and they should operate proportionally with the air flow rate.

7.4.1 - Connection:

Always follow the general safety instructions.

■ For machines supplied without a control unit:

- When selecting the cables, take into account the routing, the ambient operating temperature and the current of the connected heaters.
- The selection, securing and mechanical and electrical protection of cables must conform to the regulations and laws at the installation site.
- The power electrical connections are made directly on the heaters. Observe the tightening torque of 4 Nm,
- The safety components must be connected,
- The installed safety thermostats must cut the power supply to the heating elements,
- The safety components must be electrically connected directly to the terminals of the thermostats with manual and automatic reset located on top of the heater. Before making the connection, cut the power supply control for the electrical heaters,
- Coloured labels indicate the stage marking, their output per unit and the phase order.

7 - CONNECTIONS



Do not connect the electric heater to the ground (class 2 insulation),

■ For machines supplied with a control unit:

- The heaters are supplied cabled to a specific unit nearby,
- This unit must have a specific power supply. When selecting the cables, take into account the routing, the ambient operating temperature and the current of the connected heaters.
- The selection, securing and mechanical and electrical protection of cables must conform to the regulations and laws at the installation site. Follow the recommendations in the regulations section when selecting components and cables,
- Unwind the electric heater control unit cable(s) to the main unit. Route them by sliding them into the lower raceways (before assembling the blocks) or upper raceways (depending on the position of the electric heater in the unit),
- Use the wall feedthroughs in the block concerned.

7.4.2 - Connection principle :

The thermostats must be wired in series.

- See wiring diagram.

7.5 - Connecting the disconnect switches/circuit breakers

7.5.1 - Connecting the 20A disconnect switches/circuit breakers

- The cable used must be shielded to connect and ensure continuity of the disconnect switch/circuit breaker shielding.
- The cable shielding must be flattened against the plate (in the switch) and the nut used to tighten the packing box.

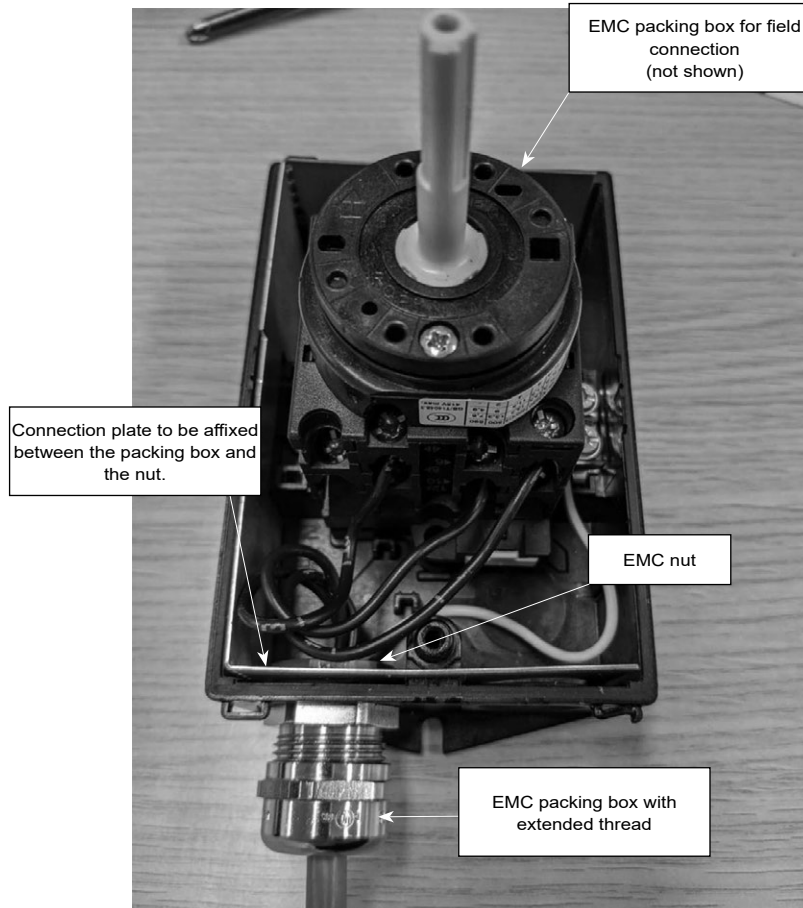

7 - CONNECTIONS

7.5.2 - Connecting the 25A / 32A / 63A / 100A switches/circuit breakers

- The cable used must be shielded to connect and ensure continuity of the disconnect switch/circuit breaker shielding.
- Use the jumper supplied at delivery; insert the cable via the supplied packing box then affix the jumper (on the cable shielding) to the shielding plate in the switch.

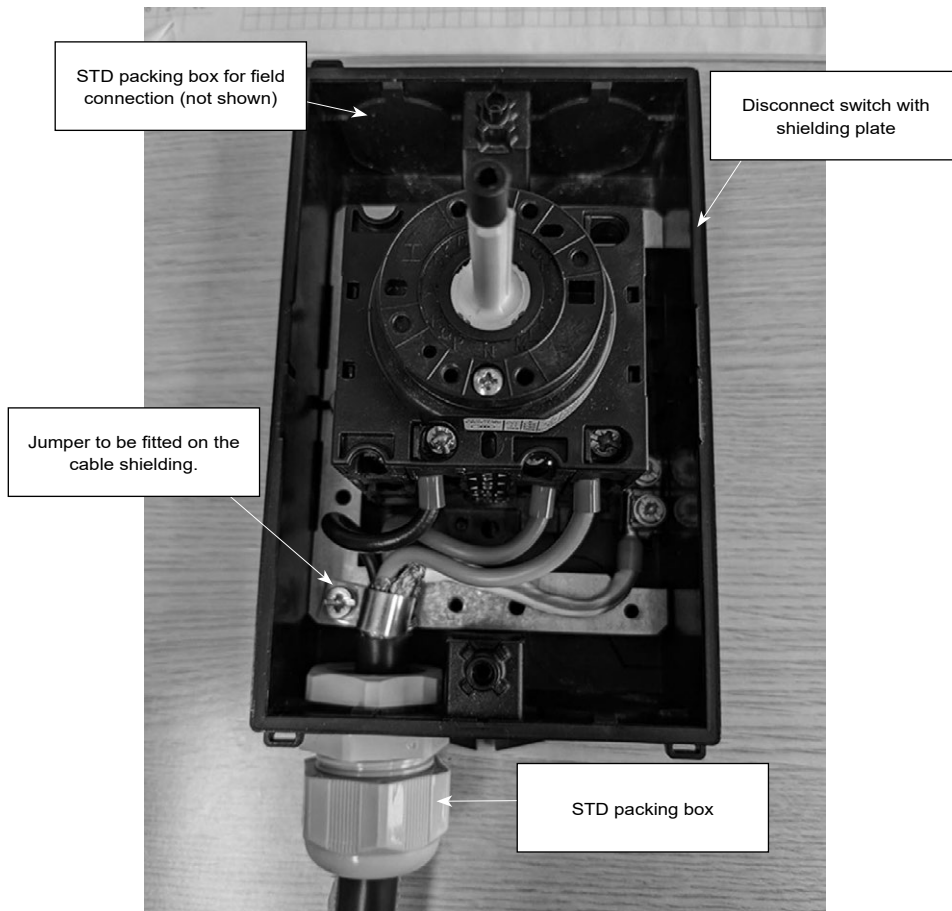

7.6 - Connecting the fans

■ Electrical danger:

- Work on the electrical components must only be carried out by an electrician or technician with the relevant training in this field, under the supervision of an electrician and in accordance with industry practice.
- When selecting the cables, take into account the routing, the ambient operating temperature and the current of the connected motor(s). Follow the recommendations in the regulations section when selecting components and cables.
- The selection, securing and mechanical and electrical protection of cables must conform to the regulations and laws at the installation site.

7.6.1 - EC motor*

All EC fan motor assemblies are supplied wired on the motor side, with cables wound on the front panel, ready for field connection. Refer to the connection instructions for EC fans.

■ Connecting the EC fan. :

"D1" digital input for authorisation (ON / OFF device)

Electronic cut-out via volt-free contact to the "D1" - "+24 V" terminals (input resistance and voltage range Technical data),

Function in Factory settings for "D1":

- Unit "ON" with contact closed.
- Unit "OFF" when the contact is open.

The "K1" relay remains armed, connections 11 - 14 are bridged. Status Out with flashing code: |1| (Diagnostic / Disruption),

7 - CONNECTIONS

"K1" relay output to indicate faults

An external fault message is possible via the volt-free contact of the built-in relay (max. contact load Technical data and wiring diagram),

Function in Factory settings for "K1":

- During operation, the relay is excited and terminals "11" and "14" are bridged.

In the event of a fault, the relay is deactivated (Diagnostic / Faults),

- In the event of cut-out by unlocking (D1 = Digital In 1), the relay remains armed.

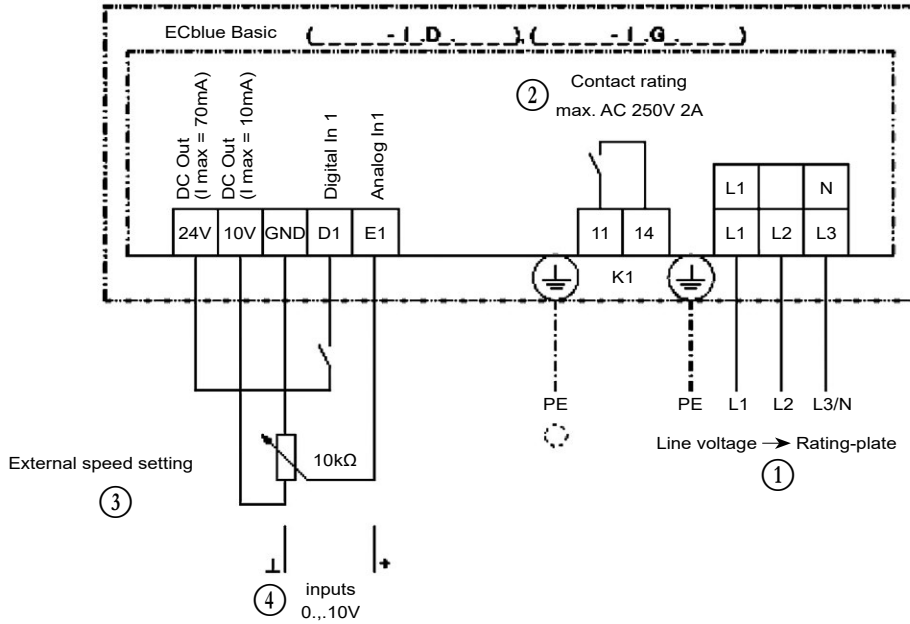

Speed determination options

	<p>Control via the 0...10 V external setpoint External wiring with a resistor (499 Ω / 0.25 W) between the "E1" and "GND" terminals parallel to the input signal is used for control via a 0...20 mA signal. The "AM-MODBUS" communication module is used to programme an inverted setpoint signal (10...0 V).</p>
	<p>Speed setpoint with a 10 kΩ potentiometer on the "+10 V" and "GND" terminals with connection to the "E1" terminal</p>
	<p>Control via an external PWM setpoint signal ("24 V" connection only available for "D" and "G" motor sizes).</p>

7 - CONNECTIONS

7.6.1.1 - Configuration with one fan-motor assembly

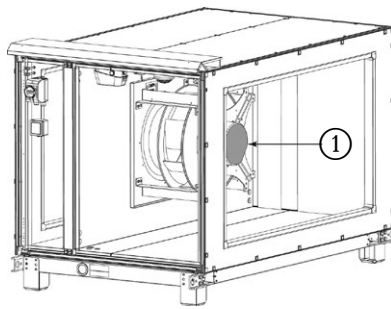

■ Connection diagram:

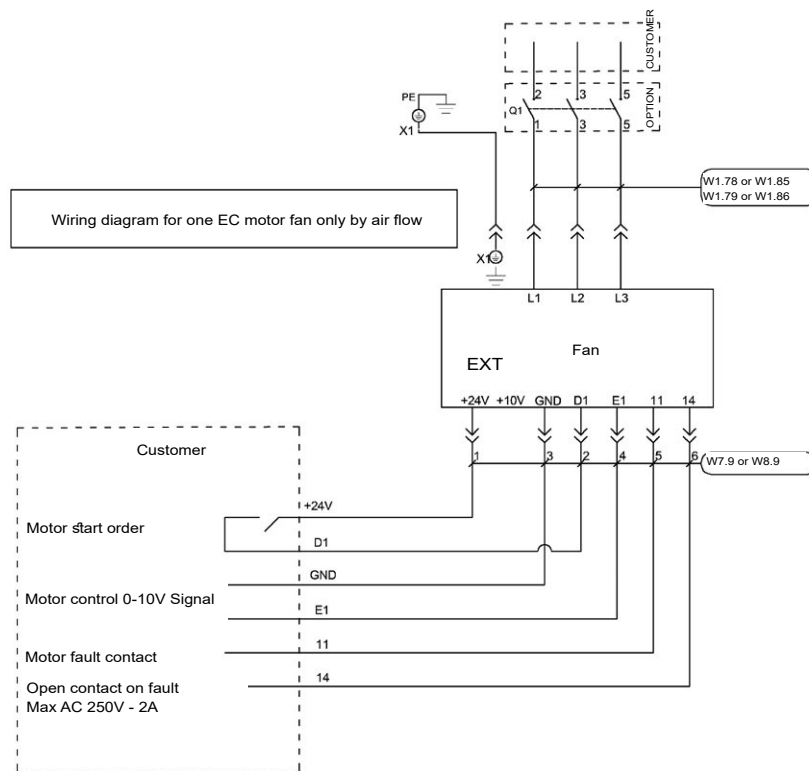

■ Cable cross-sections

Connection to the network: L1, N or L1, L2, L3	4G1,5 mm ² Ø12,7 cable, insulated end piece
Control connection: +24 V, +10 V, GND, D1, E1, K1	6x1 mm ² Ø9,5 cable, insulated end piece

7 - CONNECTIONS

7.6.1.2 - Connecting several EC fan motor assemblies without outdoor unit option

■ Connection diagram:

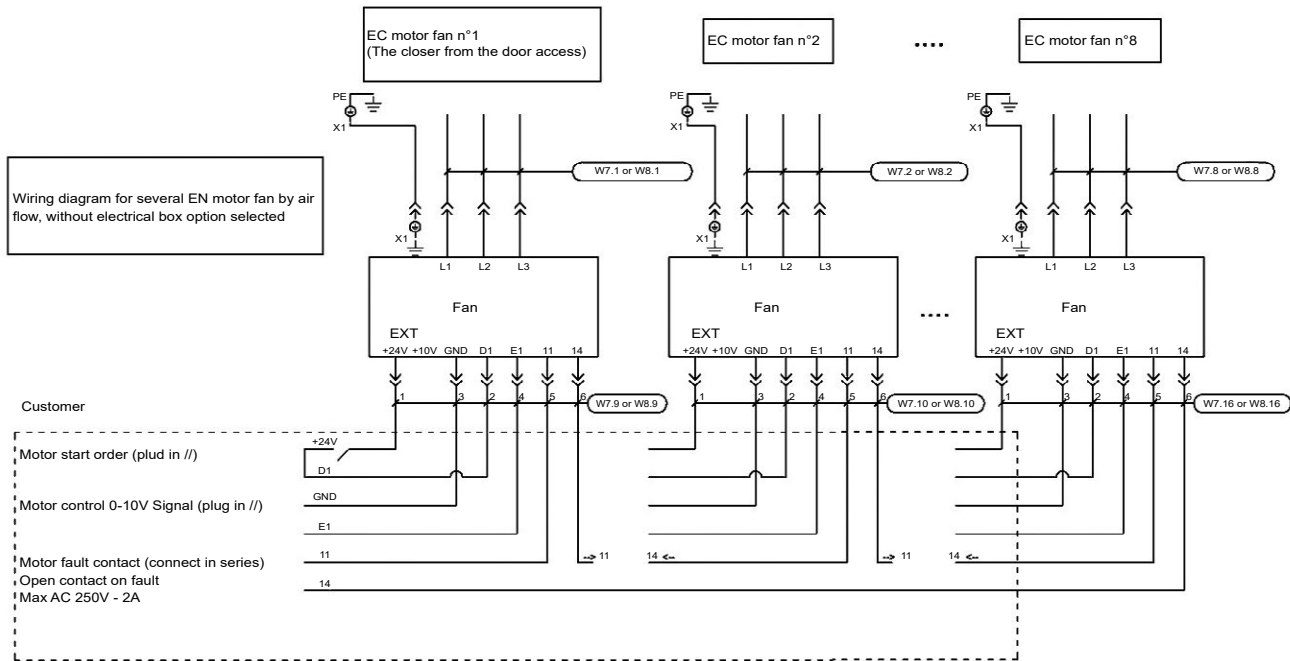

7.6.1.3 - Connecting several fan motor assemblies with optional unit outside the air stream

■ Distribution unit:

- The distribution unit ① can be used optionally when fitting at least 2 EC fan motor assemblies.

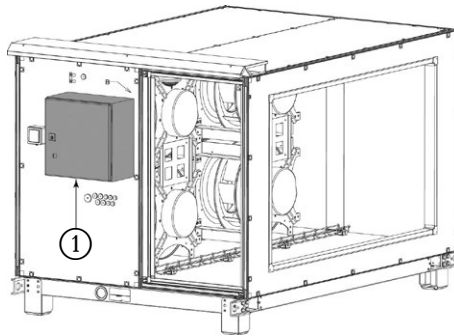

- For the wiring, refer to the diagram inside the unit.
- Two types of control are possible:

Installation: 0/10V or ModBus card

- 1: Power dividers
- 2: Earth terminals
- 3: Disconnect switch
- 4: 0/10V or ModBus card

7 - CONNECTIONS

7.6.1.4 - EC FAN-MOTOR ASSEMBLY UNIT ELECTRICAL CONNECTION

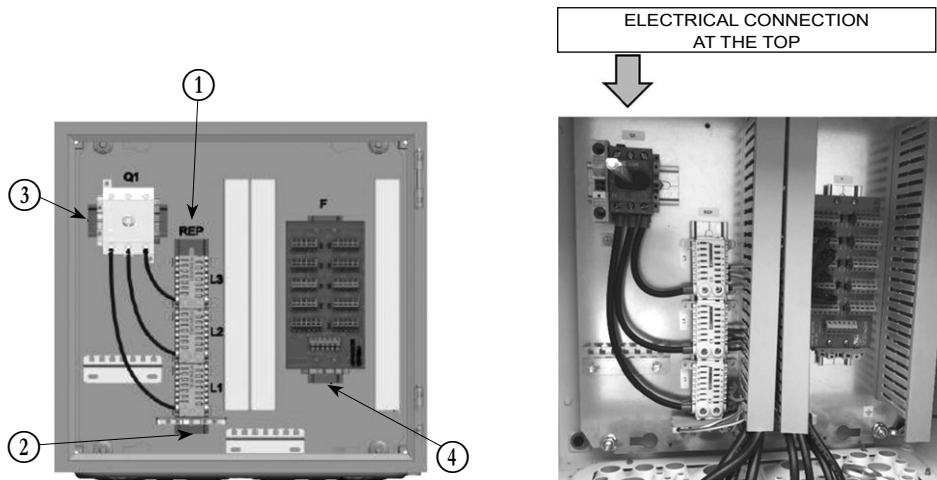

7.6.2 - AC MOTORS fan (plug fan and impeller)

■ Electrical connection:

- **A - Machine without variator and without proximity switch:**

To be connected directly to the terminal box for the motor(s),

Europe zone: Pursuant to regulation 1253/2014 concerning the implementation of directive 2009/125/CE, an asynchronous motor may not be used without a speed variator.

- Remove the cover from the motor unit to make the connection.
- Insert and connect the cables in accordance with industry practice.
- Before switching on for the first time, correctly reposition the motor unit cover.

Motor electrical connection:

The connection must be made by a qualified person following the diagrams below, in accordance with those supplied with the motors.

! The motors are equipped with a heat protection sensor which must be connected. Check the supply voltage, the input current and the protection calibration.

! For motor output of 5.5 kW or more, we recommend Y/Δ starting to limit the starting current (Id/In) and reduce wear on the transmission.

■ Dual voltage type motor with Y, Δ coupling (6 terminals):

230/400 V motor

- Supply voltage 230 V, connection (Δ): diagram A
- Supply voltage 400 V, connection (Y): diagram B

400/700 V motor

- Supply voltage 400 V, connection (Δ): diagram A
- Supply voltage 700 V, (for $P \geq 5.5$ kW), connection (Y): diagram B.

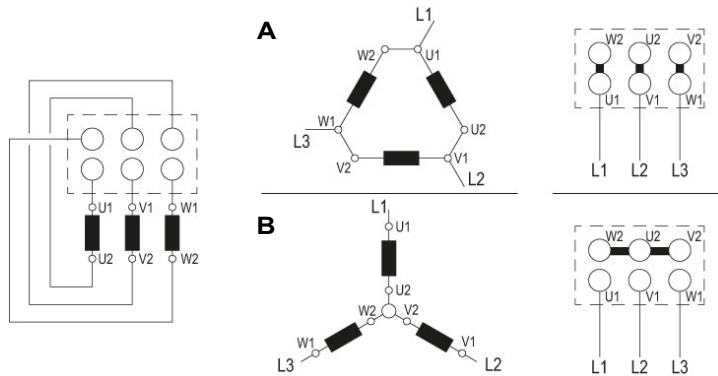

7 - CONNECTIONS

■ B - Unit with proximity switch:

- The motor(s) is/are prewired.
- The connection is to the switch terminal block

■ Authorised tightening torques and maximum terminal connection sections:

- See § 7.4.1 AC motor

■ C - Unit with frequency inverter

- In the interest of shipping safety, the inverters are not installed at delivery. Fit the inverter and the protective cover on the support provided at the front on the utilities side. Connect the cables to the inverter in accordance with the instructions in the inverter section.
- Follow the predefined wiring (see inverter manual),
- Two protective conductors must be connected in parallel.
- For machines supplied with a control unit:
 - Unwind the cables(s) fixed to the motor or the inverter.
 - Route them to the main unit by sliding them into the lower raceways (before assembling the blocks) or upper raceways (depending on the position of the fan in the unit), Use the wall feedthroughs in the block concerned.
- Connection: see wiring diagram.

■ D- Direction of rotation

- **Danger** Risk of fan damage
- For a correct direction of rotation with a 3-phase motor, make sure that terminals U1, V1 and W1 correspond to phases L1, L2 and L3 respectively.
- If necessary, swap the power supply cables at the inverter output to change the direction of rotation. (e.g. U1 with V1),

■ E- Motor protection

- All the motors have PTC type internal heat protection.
- This thermistor must be connected to the motor's control safety chain.

■ F- Starting type

- Always refer to the current standards in the country of installation.

Direct starting possible for motors below 5.5 kW.

Use star-delta or inverter starting for motors with a power above 5.5 kW.

For units installed in Europe, a frequency inverter must be fitted to conform to regulations (ErP directive),



If the frequency inverter is not supplied by us, we accept no responsibility for any damage to the motor, fan or unit.

Precautions must be taken, in particular:

- Comply with the local regulations and standards governing safety,
- Comply with the EMC levels for the installation environment required by the local regulations and standards. If necessary, fit a filter upstream and/or downstream of the variator,
- Select the power cables based on the local regulations and maximum operating conditions to withstand the nominal current indicated on the data plate of the variator and the motor. The cable must withstand a temperature of at least 70°C in continuous operation. For the cable between the variator and the motor, use 600 V AC shielded cable with 360° shield connection ("pig tail" shield connection not permitted), If necessary, fit a filter to prevent bearing currents on the motor,
- Limit the frequency to avoid exceeding the maximum speed for the different rotating components (motor, impeller, etc.) and the maximum permissible flow rate and pressure values for the various elements of the unit,
- A device should protect the motors if the fans are overloaded or jammed,
- Make sure the isolation dampers are open before authorising the ventilation,
- Ensure a fan delay that must be no less than 1minute, and to be adjusted as per the damper actioners rotary speed, when the electric heaters or GGS are stopped,
- Fit a minimum air flow control device if there is an electric heater or GGS.

7 - CONNECTIONS

7.7 - Filters



Follow the safety instructions (see § 2 - SAFETY INSTRUCTIONS),

The filter cells are flammable products, and the fire risk may increase depending on the elements filtered by the medium. Keep the filters away from flames.

Mounting, cleaning and replacement of filters pose risks of allergies and irritation of the skin, airways and eyes. When working on the filters, always use suitable Personal Protective Equipment (gloves, mask, safety glasses, etc.),

■ Connection phases:

- 1 Clean all the components upstream of the filters and the duct networks.
- 2 Clean the filter support frames.
- 3 Warning: the filters may be packaged and not installed at delivery.
- 4 Unpack the filters.
- 5 Check the condition of the filters and the sealing gaskets.
- 6 Fit the filters in the frames provided.
- 7 Lock with the runner screws or hooks, depending on the assembly. See views below:
- 8 Clean the inside of the filtration box. Remove any impurities using a vacuum cleaner and/or a cleaning product
- 9 Make sure there are no foreign objects inside the box.
- 10 Install pressure drop measuring instruments if the unit is not equipped with this option.

7.8 - Different filter locking systems:

- Runner; triangle button tightening.



- Metal hooks :

- 1 hook in each corner.



7 - CONNECTIONS

■ Precautions:

- Keep a spare set of filters in a clean, dry place.



Filters are regulated components. Comply with the regulations, directives and standards in force at the installation site.

7.9 - Standalone steam humidifier

- This section only covers the connection of the steam diffusion rails.
- Follow the instructions in the manufacturer's manual supplied with the unit when installing the hydraulic and electrical connections on the standalone steam production unit.

7.9.1 - Condensate drain pan connection

- Refer to your dimensional drawing for the diameters of the connections and their positions.
- Outlet on the front panel under the rails: threaded gas type steel connector.
- Fitting the siphon (see § 7.1 "Condensate drainage siphons"),

7.9.2 - Connecting the steam and condensate hoses:

- The air handling units are supplied with diffusion rails installed inside the unit.
- Depending on their length, the ends of these rails rest on supports. Make sure the supports are in place. To add rails to the unit at a later date, please contact your agency, who will provide you with the relevant materials.
- Connect these rails to the production unit.
- The connection is accessible from the outside on the utilities side of the front panel (unless requested otherwise),

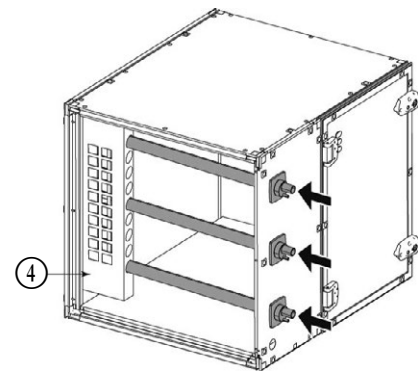
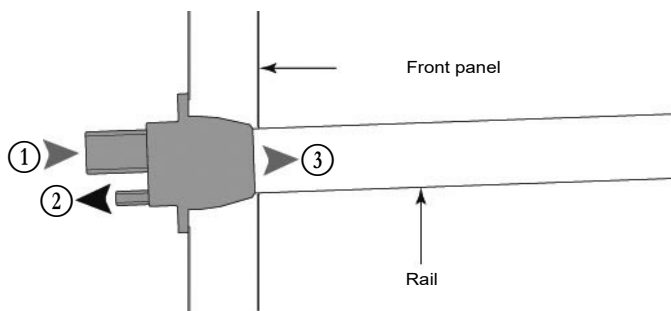

- ① Steam inlet
- ② Condensation drainage
- ③ Steam outlet
- ④ Rail support

- Only use the hoses supplied with the unit, and cut them to size if necessary to facilitate installation (max. 4 m long)
- Secure the ends of the hose to the standalone unit and the diffusion rails using metal clamps.
- It is recommended to strictly adhere to the following rules:
 - Avoid excessively tight curves in the pipes to prevent kinks or bottlenecks.
 - If the manifold is higher than the humidifier, ensure a uniform slope of at least 20% towards the humidifier to transfer the recondensed steam to the cylinder.
 - If the difference between the two heights is not sufficient to achieve this, or if the manifold is lower than the steam cylinder connector, fit the pipe high enough to be able to route it back down to the manifold, keeping the uniform slope at 5% or more.
 - Do not create pockets where steam can accumulate between the steam cylinder and the manifold.
 - Make sure the slope is as indicated.
 - The condensation flow pipe should enable the creation of a siphon to prevent the return of condensate.
 - The condensation pipe, one end of which is connected to the steam manifold, should transfer the condensed steam to the base pan, provided this is lower than the manifold or the drainage system.

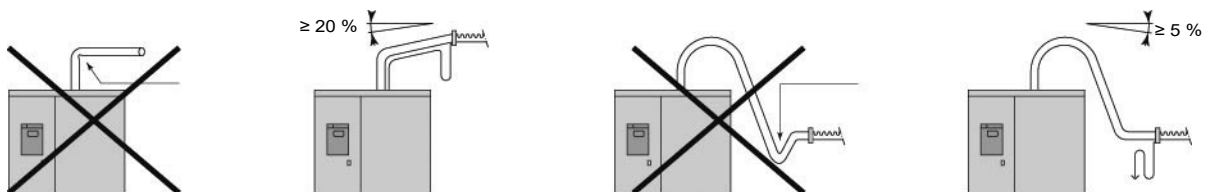

7 - CONNECTIONS

- To ensure sufficient reliability, the recommended water quality values are shown in the table below:

Recommended water quality			
Appearance	Clear, colourless, no sediment		
pH value	7 to 8,5		
Conductivity	30 mS/m max.		
Total hardness	Max. 1,2 mol/m ³	Max. 7°d.H.	Max. 12,5°f.H
Carbonate hardness	Max. 0,7 mol/m ³	Max. 4°d.H.	Max. 7°f.H
With carbonate hardness stabilisation	Max. 3,5 mol/m ³	Max. 20°d.H.	Max. 35°f.H
Total salt content	Max. 250 g/m ³		
Chloride content	0 g/m ³		
Sulphate	0 g/m ³		
Manganese	Max. 0,01 g/m ³		
Aggressive carbonic acid	0 g/m		
KMnO ₄ consumption	Max. 20 g/m ³		



Supply the humidifier with water from the network. **Do not use demineralised water.**

The water must have a conductivity of 125 to 1250 µS/cm and a hardness of 15 to 30°F.

When using softeners or treatment systems for particularly hard water, the final hardness must not be less than 40% of the initial hardness or below 15°F.

7.10 - Damper and mixing

7.10.1 - Condensate draining connection

- Refer to your dimensional drawing for the diameters of the connections and their positions.
- Outlet on front panel:
 - Threaded steel gas connector.
- Fitting the siphon (see § 7.1 "Condensate drainage siphons"),
- To avoid the risk of pinching, dampers accessible from outside must be equipped with a protective screen to prevent direct access to the blades. DIN EN ISO 12100 safety devices must be fitted.

7.10.2 - Fitting the servomotor



Before fitting the servomotors:

- Adjust the servomotor mechanical stops so that its rotation does not exceed that of the damper. Low mechanical torque can be applied to close the dampers, however it must not exceed the damper's tightening torque.**
- Make sure the damper blades can rotate freely.**
- Positions of the damper louvres:**
The damper louvres positioned on the heat recovery unit section must be in the open position.

- For units sold with the servomotor option but without control.
 - **Direct installation on the damper:**
 - The servomotor should be affixed to the plate ①,
 - Tighten the clamp against the damper shaft,
 - Position the screw ② in the servomotor groove to prevent it from rotating.

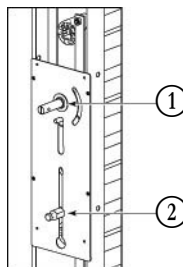

7 - CONNECTIONS

- External assembly on panel:

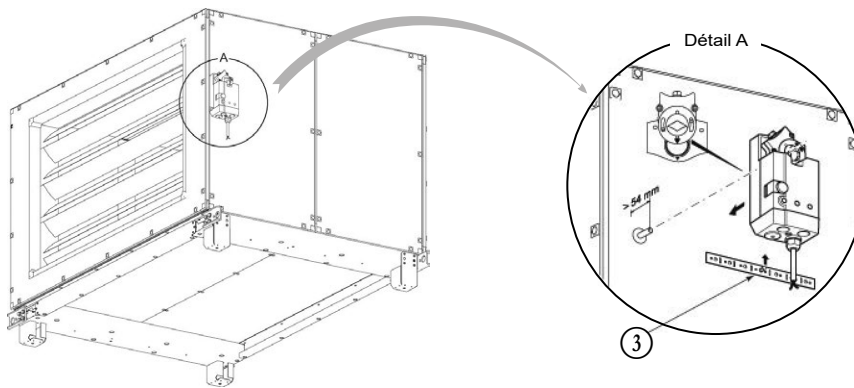

- The servomotor should be affixed to the unit's external wall,
- Tighten the clamp against the extension shaft,
- Position and affix the plate (3) on the unit's external wall to prevent the servomotor from rotating,
- If the blades are not visible, a groove on the shaft of the dampers and extensions can be used to locate the open and closed positions of the dampers.
- Setting the air flow direction

Horizontal air flow:

When closed, the groove is at right angles to the air flow direction

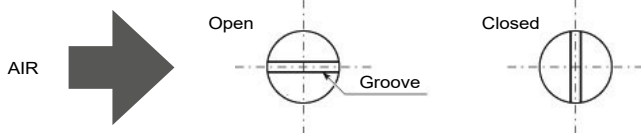

Vertical air flow:

When closed, the groove is at right angles to the air flow direction

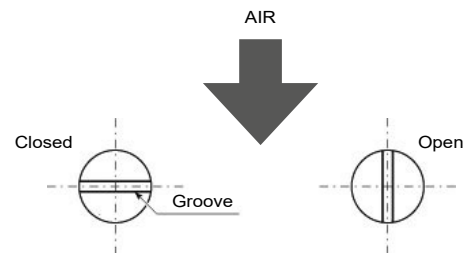

7.10.3 - Electrical connection.

- For machines supplied without a control unit:
 - When selecting the cables, take into account the routing, the ambient operating temperature and the current of the connected motor(s),
 - The selection, securing and mechanical and electrical protection of cables must conform to the regulations and laws at the installation site. Follow the recommendations in the regulations section when selecting components and cables.
 - **Electrically connect the servomotors.**
- Sheet bellow indicates the electrical supply for each of the equipments, for information only. To get the information about the electrical intensity, please refer to the product datasheet supplied by the salesman.

	Electrical supply
Electrical coil	400V 3P + G
Steam humidifier	400V 3P + G
Adiabatic humidifier	400V 3P + N + G
Light bulb	230 + N
Smoke detector (sensor)	230 + N
Smoke detector (electrical cabinet DAD – only for products with control)	24V
Actionners for dampers and valves	24V
Heat recovery wheel with constant speed	400V 3P + G
Heat recovery wheel with variable speed	230 + N
Motorfans and / or variable frequency drive	Upon selection
Control (if supplied by the factory)	400V 3P + G

- Units supplied with control unit:
 - Unwind the cable(s) fixed to the servomotors.
 - Route them to the main unit by sliding them into the lower raceways (before assembling the blocks) or upper raceways (depending on the position of the servomotors in the unit), Use the wall feedthroughs in the block concerned
 - Connection: see wiring diagram.

7 - CONNECTIONS

7.11 - Heat recovery units

Recommendation: Whether plate or rotary heat exchangers are used, air filtration is recommended to prevent premature fouling.

7.11.1 - Plate heat exchangers

- Condensate draining connection
 - Refer to your dimensional drawing for the diameters of the connections and their positions.
 - Outlet on the front frame: threaded gas type steel connector.
 - Fitting the siphon (see § 7.1 "Condensate drainage siphons"),
- Electrical connection of the bypass damper servomotors
 - See dampers section (see § 7.8 Damper)

To prevent the risk of freezing and ice in the heat exchanger, fit pressure or temperature sensors.

7.11.2 - Rotary heat exchangers



To carry out maintenance on the recovery wheel, it must be possible to remove it completely from the AHU (e.g. to change a rotor bearing). It is therefore essential to leave sufficient free space for this during installation. For a VDI 6022 certified AHU, heat recovery units with leaks are considered to be recirculation units unless a sufficient, verified pressure differential is guaranteed in the heat recovery unit compared to the outdoor air. The transfer of harmful substances caused by rotation or tipping of the components must also be monitored.

If such transfer is unavoidable, the use of these heat recovery units must only be authorised if air recirculation inside the system meets the expected level of hygiene.

- Handling is only permitted by qualified personnel
- For certain sizes, the rotary heat exchanger comprises a self-contained block. This block is supplied resting on its rear surface.
- Stand the module upright using the two installed lifting lugs.
- Lift the module. Only use the lifting lugs affixed to the frame.
- Before affixing the unit's other blocks, remove the lifting lugs.
- During handling, when the heat exchanger is positioned upright, always check that it is properly supported to prevent it from falling. Never leave it standing and unsecured to the ground, as it could be blown over.

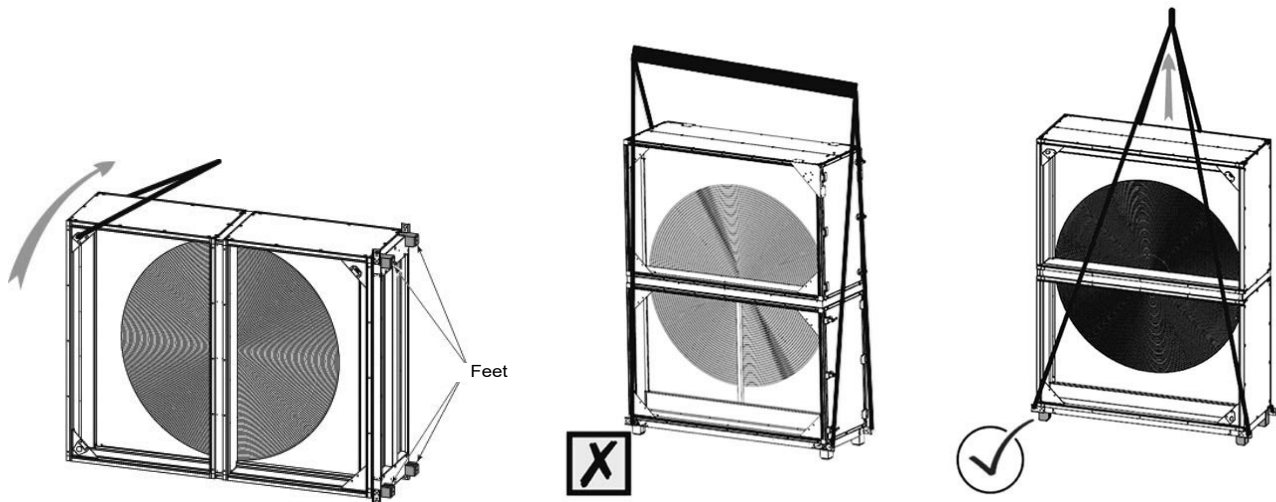

- Condensate draining connection:
 - Refer to your dimensional drawing for the diameters of the connections and their positions,
 - Outlet on front frame: for Ø 32 mm tube,
 - Fitting the siphon (see § 7.1 "Condensate drainage siphons"),
- Electrical connection:
 - For machines supplied without a control unit:
 - When selecting the cables, take into account the routing, the ambient operating temperature and the current of the connected motor(s), (see table below)
 - The selection, securing and mechanical and electrical protection of cables must conform to the regulations and laws at the installation site. Follow the recommendations in the regulations section when selecting components and cables.

7 - CONNECTIONS

■ Cables recommended for connection:

- Fixed speed motor:
 - 4G1.5 supply

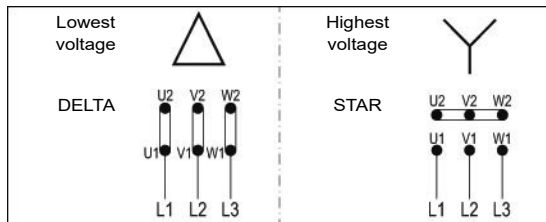

• Variable-speed motor:

- 3G1.5 supply
- 4x1 control

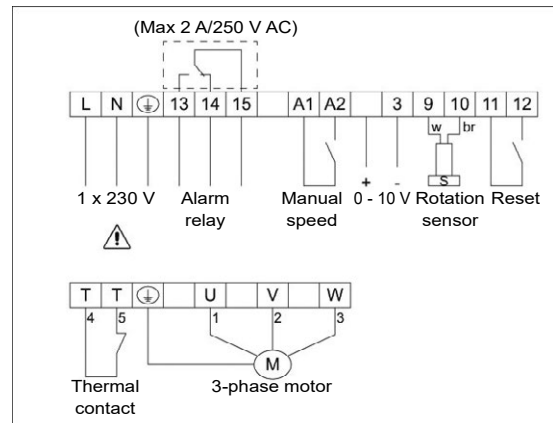

To prevent the risk of freezing and ice in the heat exchanger, fit pressure or temperature sensors.

For units supplied with integrated control, the power cable and the inverter control cable (option) must be fed into the upper raceway through the upper panel.

Inside the block, make sure that the cables are correctly secured so that they never come into contact with the moving wheel.

8 - CONTROL

8.1 - AHU with control

- If the control is supplied by the manufacturer, refer to the manual provided with it.

8.2 - AHU without control

- If the control is not supplied by the manufacturer, the manufacturer accepts no responsibility for any damage that may occur to the various controlled components due to faults or improper use. Special precautions must be taken, in particular:
 - The temperature in the air handling unit must not exceed the limits (upper or lower) for which it has been designed,
 - Low air flow protection must be integrated in the fan control,
 - If an electric heater or gas burner is used, safety thermostats must be installed to shut them down in the event of a problem,
 - Pressure sensors must monitor the filter fouling level in order to prevent breakage of the filters due to clogging,
 - The adjustment values must not exceed the maximum permissible pressure difference on the filters and on the plate heat exchangers (see AHU technical selection),
 - A device must be fitted to protect the motors or issue a notification if the fans become jammed.
 - The flow rate and pressure in the duct must be monitored to prevent them from exceeding the limit values,
 - Make sure the isolation dampers are open before authorising the ventilation,
 - Ensure a fan delay that must be no less than 1minute, and to be adjusted as per the damper actioners rotary speed, when the electric heaters or GGS are stopped,
 - Fit a minimum air flow detecting device if there is an electric heater or GGS
 - Protect the ventilation motors and turbines against overspeed,
 - Comply with the required insulation and pollution classes for the electrical components and cables to ensure compliance with the low voltage directive or the regulations in force at the installation site. Take the altitude into account.
- For VDI 6022 certification, in case of shut-down of the fan or air conditioning system:
 - The humidifier must be shut down automatically. A stage shut-down is required to allow the humidification chamber to be dried prior to complete shut-down.
 - The cooling coil's water supply must be shut down automatically. The cooling coil must be dried before the fan shuts down.
 - If the shut-down occurs at night or for a maintenance operation, the dampers installed in the ductwork (outdoor air, discharge air and air inlet) must close automatically to prevent air from entering the system due to wind or inertial forces.

9 - COMMISSIONING

9.1 - Siphon

- The siphon must be activated during commissioning, or after each period of prolonged downtime. To do this, fill the drain pan with water and check that it drains quickly with no stagnant areas.
- The siphon level must be checked periodically. Operation without condensation may result in evaporation of the water contained in the siphons.

9.2 - Pre-commissioning check

Commissioning must be performed by qualified personnel in accordance with the safety rules and standards.

- Check the following points:

Remove:

- Any protective films,
- All shipping safety devices.

Check:

- All of the casings (structure, profiles, doors, gaskets, handles, panels),
- That the unit and its components meet the order specifications,
- That all of the documents and safety equipment required by the applicable European standards are present,
- The network voltage: It must match the unit voltage and its value must remain within the permissible limits (+10% to -10% of the nominal voltage),
- The calibration of the heat protection in relation to the current of the various components,
- The tightness of the connections,
- The internal cleanliness of the unit: Remove any foreign objects from inside it (paper, packaging, dust, etc.),

Make sure all electric components are grounded.

During lifting operations, the tunnel sealing gaskets are subjected to mechanical stress.

They must be checked.

Also ensure that the ventilated room is clean before starting up the extraction.

9.3 - Filters



Follow the safety instructions (see § 2 - SAFETY INSTRUCTIONS),

The filter cells are flammable products, and the fire risk may increase depending on the elements filtered by the medium. Keep the filters away from flames.

Mounting, cleaning and replacement of filters pose risks of allergies and irritation of the skin, airways and eyes. When working on the filters, always use suitable Personal Protective Equipment (gloves, mask, safety glasses, etc.),

- Commissioning phases:

- 1 Check the condition of the filters and the sealing gaskets (except for assembly with bare runners),
- 2 Check for mechanical jamming of the filters,
- 3 Clean the components upstream of the filters and the duct networks,
- 4 Clean the filter support frames,
- 5 Check the operation of the pressure drop measuring instruments, For VDI 6022 installation, make sure a pressure gauge is present.
- 6 Clean the inside of the filtration box Remove any impurities using a vacuum cleaner and/or a cleaning product,
- 7 Make sure there are no foreign objects inside the box,
- 8 It is strongly recommended, if regulations permit, to operate your system for a few hours with prefilters only In fact, large quantities of dust and other compounds can quickly clog the filters - in particular high efficiency filters - and affect the operation and performance of the unit,
- 9 Repeat the operation several times if necessary,
- 10 All of the final filter stages can then be installed,
- 11 Check the pressure drop on each filter stage.

FILTER (EN 779 / ISO 16890)	PRESSURE DROPS recommended before replacement
G1 to G4 / ISO coarse	Smallest value between: $\Delta p_{init} + 50 \text{ Pa}$ $\Delta p_{init} \times 3$
M5 to F9 / ISO ePM ₁₀ , ePM _{2.5} and ePM ₁	Smallest value between: $\Delta p_{init} + 100 \text{ Pa}$ $\Delta p_{init} \times 3$
E10 to H14	$2 \times \Delta p_{init}$

For further clarification, please refer to the internal release specifying the pressure drop data based on the filter fouling level (clean, semi-fouled, fouled),

9 - SYSTEM START-UP

The manufacturer cannot be held liable if the filter is replaced using a brand or model that differs from the original filter brand or model (EN 846 certified for hygiene versions),

Activity	Action, if required	1 month	3 months	6 months	12 months	24 months
Check for unacceptable contamination, damage (leaks) and odours	Replace the corresponding filter		X			
Check the pressure differential	Replace the filtration stage			X		
Maximum interval before replacement of the first filtration stage					X	
Maximum interval before replacement of the second filtration stage						X

9.4 - Fan

9.4.1 - Mains voltage

- Make sure the network voltage matches that shown on the data plate, and that it is within the permissible tolerances.
- For a 400 V/50 Hz network, voltage tolerance $\pm 10\%$,
- The phase unbalance must not exceed 2% for voltage and 10% for current.

9.4.2 - Pre-commissioning check



Follow the safety instructions (see § 2 - SAFETY INSTRUCTIONS),

When working inside the unit, make sure that the motors are switched off and the fans are not running.

- Before starting up the fans, make sure that the fan block is clean and free from foreign objects. Clean if necessary, paying attention to production residue, e.g. oils and cleaning agents. Be sure to thoroughly clean the area around the mounting shims removed after transport.
- Remove all the transport safety devices (①, shims, etc.) Replace the bolts with the hexagonal bolts supplied with the fan.

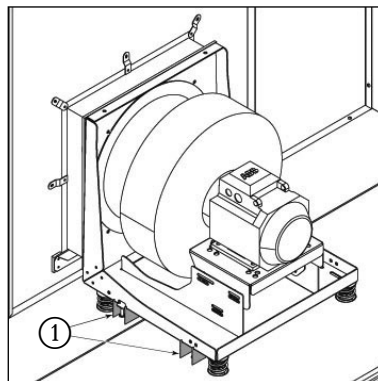

- Manually check to ensure that the fan rotates correctly without friction or abnormal noises.
- Make sure that the wheel is centred on the intake section. Check the spacing "A", This spacing must be the same around the entire wheel. The value "B" (coverage of the inlet by the wheel) must be approximately 1% of the wheel diameter.

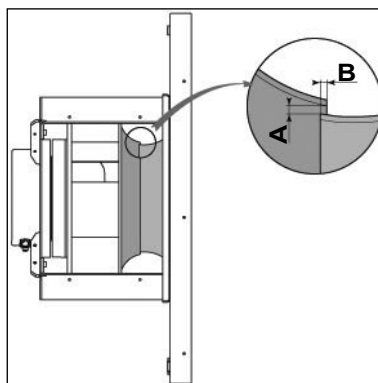

- Make sure that the impeller is correctly balanced
- Check the tightness of the mountings (AC motors)
- Check the mounting of the fans on the partition (M8 screw, 20 Nm tightening for EC motors)
- Make sure that each outlet and inlet on the block is not obstructed, and that the dampers are open.

9 - SYSTEM START-UP

- Check the condition and mounting of the protection accessories (e.g. grille option)
- Check the suspension mounts (AC motors)
- Check the condition of the flexible sleeves (AC motors)
- Before use, check the wiring between the variator and the motor or between the distribution unit and the motors (see § 7 - CONNECTION) and the wiring diagrams provided.
- Check the cleanliness of the fan, as fouling of the blades may cause the fan to become unbalanced, resulting in damage.
- Remove any impurities using a vacuum cleaner and/or a cleaning product.

9.4.3 - Commissioning

■ EC motor

- To activate limitation of the starting current, wait at least 90 seconds between shutdown and restarting.

■ AC motor

- Check the motor's direction of rotation: to do this, send a pulse via the starting control.
- If necessary, swap two phases downstream of the starter to change the direction of rotation (e.g. L1 with L2),

■ Frequency inverters



- Follow the predefined wiring (see inverter manual),
- When using a frequency inverter, before commissioning, it is essential to limit the upper frequency to avoid exceeding the maximum speed for the rotating parts and prevent motor overload.
- Also check the fan operation, one frequency at a time. Mark anywhere there may be resonance zones in order to eliminate them by frequency hopping (see inverter manual),

■ Fan motor assembly

- Check for the presence of air flow.
- Measure the input current on each phase. The currents measured must not exceed the value shown on the data plate.

9.4.4 - Fans with belt and pulley transmission:

Always follow the practical rules and instructions concerning shaft parallelism and alignment of the transmission. Firstly, carefully check the pulley alignment before making any thorough adjustments to the tension of the belt(s).

A - Pulley alignment:

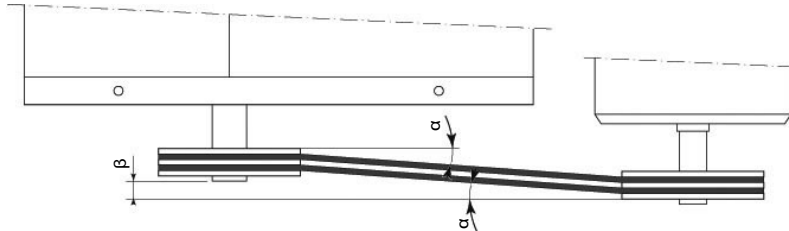

α max. $< 0.5^\circ$.

β max. < 4 mm per metre of centre distance.

During commissioning and after any work on the transmission, check its alignment using a laser alignment tool or a straightedge placed on the machined surface of the two pulleys, or using a string.

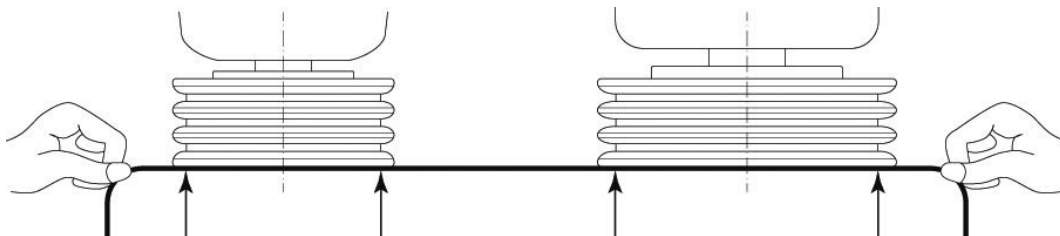

B - Belt tension:

Note: The belt tension must be checked in all cases and before system start-up.



For ATEX applications, refer to standard EN 149866.

Excessive tension on the belt(s) results in unnecessary force on the bearings, which can lead to premature wear on the assembly.



Insufficient belt tension can cause slippage, overheating and premature wear of the belt.

9 - SYSTEM START-UP

The belts have only been pretensioned for storage and shipping purposes. It is essential to tension them using the procedure described below:

Deflection test:

The belt tension must be checked and corrected using a suitable measuring instrument (tensiometer or dynamometer),

E_a calculation:

- $E_a = (e \times E)/100 =$ Deformation in mm for a pulley centre distance of 100 mm
- $e =$ Pulley centre distance in mm
- $E =$ See table below for the value
- $f =$ Force applied

At the centre of the centre distance "e", apply a force "f", as determined in the table below, to each belt. Set the belt tension to obtain the calculated deflection E_a .

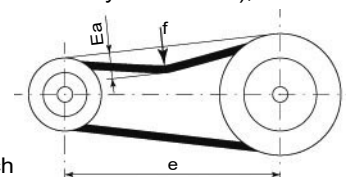

Belt type	Load to be applied per belt f (N)	Small pulley diameter mm	Belt deformation for a pulley centre distance of 100 mm - E (mm)
SPZ	25	$56 \leq 71$	2,45
		$< 71 \leq 90$	2,20
		$< 90 \leq 125$	2,05
		125	1,90
SPA	50	$71 \leq 100$	3,20
		$< 100 \leq 140$	2,75
		$< 140 \leq 200$	2,55
		200	2,45
SPB	75	$112 \leq 160$	3,00
		$< 160 \leq 224$	2,55
		$< 224 \leq 355$	2,22
		355	2,10
SPC	125	$180 \leq 250$	2,55
		$< 250 \leq 355$	2,20
		$< 355 \leq 560$	2,00
		560	1,90

During commissioning, the belt tension must be checked after 48 hours of operation.

9.5 - Heating and Cooling coil

- Take all necessary measures to prevent the water in the coils from freezing during operation or when the air handling unit is powered off.
- Install thermostats and/or safety pressostats.
- Glycol protection: Metering should be based on the temperature (see table below),
- This gives the minimum glycol concentrations based on the freezing point:

Concentration	%	0	10	20	30	40	50
Ethylene glycol	°C	0	-3	-7	-14	-24	-35
Propylene glycol	°C	0	-4	-8	-12	-20	-33

Other products are available. Refer to the manual provided by the antifreeze supplier.

- If you use a concentrated dilutable solution to protect your hydraulic circuit, please follow the instructions below:
 - Never add pure antifreeze product followed by water,
 - Always prepare the correctly metered water + antifreeze + corrosion inhibitor mixture in a container before adding it to the system,
 - Add the water/antifreeze/inhibitor and pressurise using a hydraulic pump,
 - Circulate the mixture throughout the system for at least 2 hours before starting up the unit,
 - Check the final metering obtained with a density meter or a refractometer,
 - Check the pH obtained using strips of pH paper or a pH-meter (see water quality table below),
 - Affix, in a visible location, a label stating:
 - That the system contains antifreeze,
 - The name of the product and the supplier,
 - The metering and pH at system start-up.
- If a top-up is required, it must be done using a mixture identical to that originally used. Same products, same metering, same procedure.
- During complete or partial draining, the water or coolant must not be drained directly to the sewer or the rainwater network. Consult the regulations in force at the installation site.
- Do not exceed the permissible pressure and temperature values. Refer to the unit's technical specifications.
- The water or antifreeze mixture circulating in the heat exchangers must be filtered and must not contain any impurities, to prevent fouling. The performance of a fouled heat exchanger will be severely reduced.
- The water or antifreeze mixture must be correctly treated to prevent corrosion or attacks on the materials used.

9 - SYSTEM START-UP

Recommendations concerning the quality of the water used for the heat exchangers: See table below or regulations in force at the installation site.

The quality of the water or antifreeze mixture must be checked periodically

Description	Symbol	Values	Consequences in case of non-compliance	
Hydrogen ion concentration	pH	7,5 - 9	<7	Corrosion
			>9	Deposits
Calcium and magnesium content	Water hardness (Ca/Mg)	4 - 8,5 x Δ	>8,5	Deposits
Chlorine ions	Cl ⁻	<50 ppm		Corrosion
Iron ions	Fe ³⁺	<0,5 ppm		Corrosion
Magnesium ions	Mg ²⁺	<0,05 ppm		Corrosion
Carbon dioxide	CO ₂	<10 ppm		Corrosion
Hydrogen sulphate	H ₂ S	<50 ppb		Corrosion
Oxygen	O ₂	<0,1 ppm		Corrosion
Chlorine	Cl ₂	<0,5 ppm		Corrosion
Ammonia	NH ₃	<0,5 ppm		Corrosion
Carbon/sulphate proportion	HCO ₃ ²⁻ /SO ₄ ²⁻	>1	<1	Corrosion

1/1.78°D = 1°Fr with 1°Fr = 10 g CaCO₃/m³

ppm = parts per million (mg/l)

ppb = parts per billion (mg/l)

9.5.1 - Filling



Cut the electrical supply before carrying out any work

- If filling and bleeding are not carried out correctly, air pockets may form, resulting in reduced exchanger performance.
- Fill via the low point to prevent air from entering and water hammer.
- Open the bleed valves and fill the coil.
- Close the bleed valves when no more liquid comes out of them.
- Check the tightness of the connections and retighten if necessary.

9.5.2 - Cooling coil:

- Make sure the pan is clean and that the condensate drainage is unobstructed.
- Check whether the cells of the droplet eliminators (optional) are correctly installed.

9.5.3 - Steam or superheated water coil:



Only operate the steam or superheated water coils when the fan is running, in order to avoid the risk of overheating.

9 - SYSTEM START-UP

9.6 - Electric heater

9.6.1 - Electric heater pre-commissioning checks:



Follow the safety instructions (see § 2 - SAFETY INSTRUCTIONS),

- Check for the presence of an air flow detection device.
- Make sure the safety thermostats are electrically connected. Check the pin couplings (star as standard) as per the wiring diagram.
- Check the tightness of the connections: Tightening torque 4 Nm.
- Remove any impurities using a vacuum cleaner and/or a cleaning product.



Do not use a cleaning product or cloths with detachable fibres (e.g. cotton/wool) on the heating elements.

- Make sure the electric heater casing is clean and free from foreign objects

9.6.2 - Electric heater system start-up:

- Never operate the heater when the fan is stopped.
- Check whether the safety thermostats operate correctly.
- Check the fan delay time that must be no less than 1minute, and to be adjusted as per the damper actioners rotary speed.
- For variable flow operation, adapt the heater power to the air flow rate.
- Check the power absorbed by each supply phase for the electric heater and compare these values to those shown on the data plate.
- Retighten the connections after 48 hours of operation.



ELECTRICAL DANGER: Door for directly accessing the electrical connections. Lock the door with the key once closed.

9.7 - Steam humidifier

For the adiabatic humidifier, see the IOM for the adiabatic evaporative humidifier.



Follow the safety instructions (see § 2 - SAFETY INSTRUCTIONS),

9.7.1 - Pre-commissioning check

- Check the cleanliness of the rails and the pan and the position of the eliminator cells and look for any damage.
- Make sure the water shut-off valve to the humidifier is open.
- Check the condition of the pipe assembly (supply/drainage/condensates),
- The drain pan siphon (option) must be activated during commissioning.
- Make sure the box is clean and free from foreign objects. Remove any condensate using a vacuum cleaner and/or a cleaning product.
- Check the wiring.
- Check that the humidity sensor (option) is operating correctly.
- Follow the instructions in the manual from the manufacturer of the standalone device supplied with the unit.

9.7.2 - Commissioning

- Follow the instructions in the manual from the manufacturer of the standalone device supplied with the unit. If the control (option) is supplied by us, consult the control manual.
- In this phase of the system start-up, it may be a while before the nominal production rate is reached. This depends primarily on the conductivity of the supply water, and may be several hours.

9 - SYSTEM START-UP

9.8 - Damper and mixing

9.8.1 - Condensate drain

- In the mixing box:
 - Check the cleanliness of the drain pan
 - Fill the drain trap.
 - Check that the condensate is draining correctly

9.8.2 - Commissioning



Follow the safety instructions (see § 2 - SAFETY INSTRUCTIONS),

- Damper:
 - Make sure the dampers are in the open position before starting up the fans.
 - Make sure the damper casing is clean and free from foreign objects. If necessary, remove any impurities using a vacuum cleaner and/or cleaning product.



The sharp increase in the air pressure when the fire damper is closed may cause irreversible damage to the blades.



For double flow units with fans on each side of a rotary wheel exchanger, and with optional mixing damper : installer shall take care about differential pressure on each side of the mixing damper, to ensure that the airflows comply with the product selection. A too high pressure difference could generates an inappropriate control, and / or issue in controlling the unit, and / or could lead to an impossibility to get the airflows indicated in the product selection datasheet, and / or to have an air recycling in the wrong direction (from fresh air to exhaust air)

- Servomotors:
 - Actuate the servomotors in the fully closed position. Make sure the dampers are fully closed and that the blades are perfectly joined.
 - Check the damper's direction of rotation (servomotor uncoupled) and correct if necessary.
 - Retighten the servomotor coupling.
 - If necessary, set the blades to fully closed and adjust the end of travel.
 - Actuate the servomotors in the fully open position. Make sure that the blades are parallel to the air flow direction.
 - If necessary, set the blades to fully open and adjust the end of travel.
 - If the blades are not visible, a groove on the shaft of the dampers and extensions can be used to locate the open and closed positions of the dampers.



AHUs for ATEX zones must only be equipped with suitable servomotors. Electrical equipment must be grounded + alu. blades

9 - SYSTEM START-UP

9.9 - Heat recovery unit

9.9.1 - Plate heat exchangers



Follow the safety instructions (see § 2 - SAFETY INSTRUCTIONS),



The maximum permissible delta pressure per exchanger between the two air flows must never be exceeded: this pressure is indicated in the technical selection of the AHU.

Between the closing of the fire dampers and the AHU shut-down, the operation of the unit may not be deemed compliant with the selection. Use suitable safety devices in order to remain within the specifications of the AHU.

9.9.1.1 - Pre-commissioning check

- Cleanliness is a determining factor in the unit's performance, therefore check the condition of the plates, the fouling level, the corrosion level and for any damage. Remove any impurities using a vacuum cleaner and/or a cleaning product.
- Check the condition of the gaskets and make sure there are no foreign objects.
- The drain pan siphon (option) must be activated during commissioning.
- Check the servomotor wiring if dampers are installed.

9.9.1.2 - Commissioning

- Make sure the Bypass dampers are operating correctly (See section 9.8 Dampers),
- Make sure the pressure and temperature sensors are operating correctly.

Positioning of the pressure tapings

■ Frost protection

- Using the pressure sensor is on the return flow (exhaust air), (Pressure tapings 2 and 4),
- Using the temperature sensor, on the fresh air flow upstream of the exchanger.

The triggering of the frost protection causes the exchanger by-pass to open.

The maximum permissible pressure is checked by measuring the delta pressure between the fresh air flow and exhaust air flow on the fan side (the side where the positive/negative pressure is greatest),

The triggering of the exchanger's maximum pressure safety mechanism must stop the fans immediately (risk of breaking the exchanger),

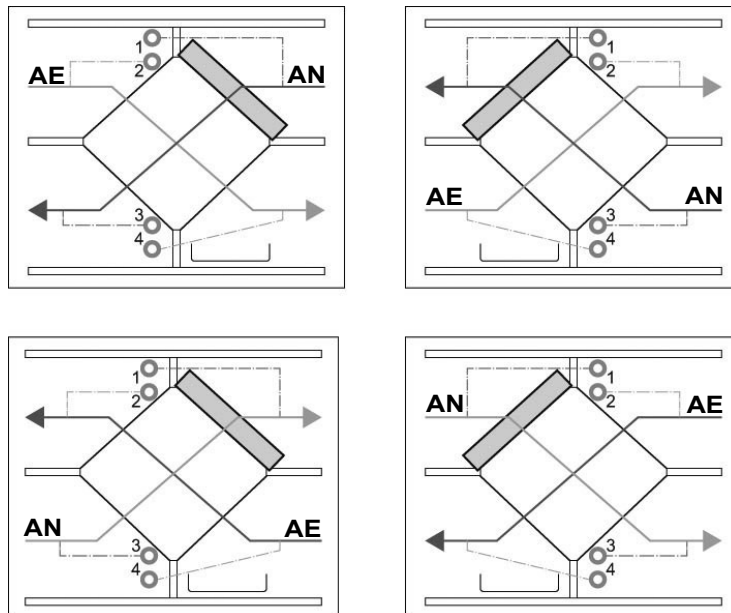

AN: Fresh air. Pressure tapping to be connected to 1 and 3.
AE: Exhaust air. Pressure tapping to be connected to 2 and 4

9 - SYSTEM START-UP

9.9.2 - SPECIAL JUXTAPOSE FUNCTION

Pressure connections:



Connect up the flexible tubes for the pressure connections.

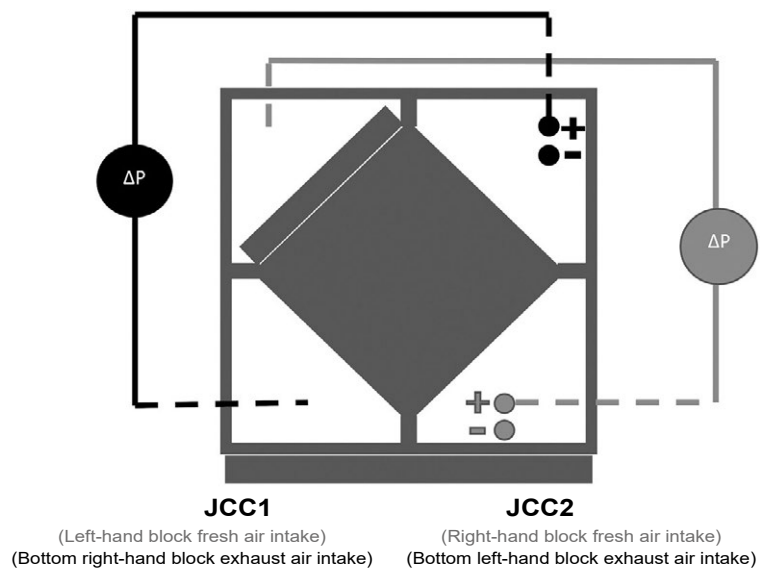
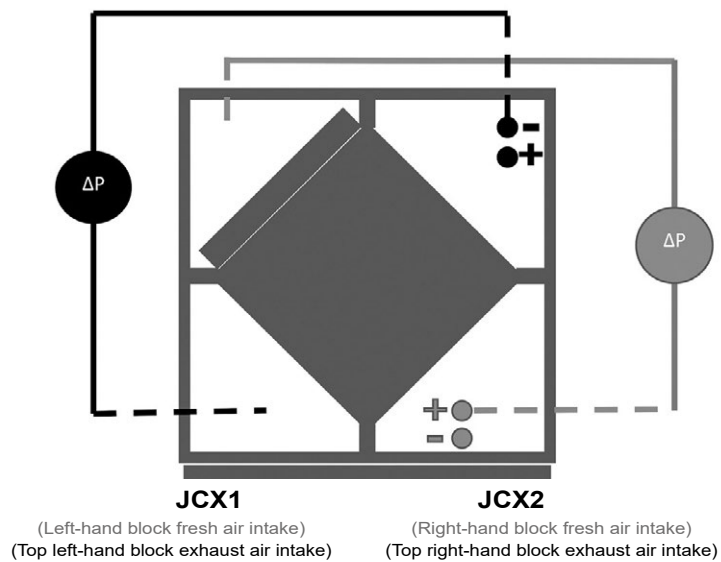

9 - SYSTEM START-UP

9.9.3 - Rotary heat exchanger system start-up



Follow the safety instructions (see § 2 - SAFETY INSTRUCTIONS),

■ Wheel pre-start-up check

- Cleanliness is a determining factor in the unit's performance, therefore check the condition of the fins, the fouling level, the corrosion level and for any damage.
- Check the condition of the gaskets and make sure there are no foreign objects.
- Check that the wheel rotates freely (no friction against the frame)
- Check the condition and tension of the belt. There should be no slippage. Cut the belt to size if necessary (see procedure §10.8.2 Rotary heat exchangers),
- The drain pan siphon (option) must be activated.
- Check the supply voltage and the wiring of the drive motor.
- Check the motor alignment.
- The rotor bearings are lifetime lubricated and do not require any special lubrication (except for large wheels supplied in several sections - depends on supplier),

■ Commissioning:

- Check the wheel's direction of rotation (if there is a purge sector option), In the event of an error, swap two phases on the motor.
- Make sure the rotation monitoring device is operating correctly.
- Measure the rotation speed.
- Measure the input current.
- Make sure the pressure and temperature sensors are operating correctly.

9.9.4 - Rotary partial heat exchanger system start-up



Follow the safety instructions (see § 2 - SAFETY INSTRUCTIONS),

■ Wheel pre-start-up check

- Cleanliness is a determining factor in the unit's performance, therefore check the condition of the fins, the fouling level, the corrosion level and for any damage.
- Check the condition of the gaskets and make sure there are no foreign objects.
- Check that the wheel rotates freely (no friction against the frame)
- Check the condition and tension of the belt. There should be no slippage. Cut the belt to size if necessary (see procedure §10.8.2 Rotary heat exchangers),
- The drain pan siphon (option) must be activated.
- Check the supply voltage and the wiring of the drive motor.
- Check the motor alignment.
- The rotor bearings are lifetime lubricated and do not require any special lubrication (except for large wheels supplied in several sections - depends on supplier),

■ Commissioning:

- Check the wheel's direction of rotation (if there is a purge sector option), In the event of an error, swap two phases on the motor.
- Make sure the rotation monitoring device is operating correctly.
- Measure the rotation speed.
- Measure the input current.
- Make sure the pressure and temperature sensors are operating correctly.

9.9.5 - Mixing and bypass system start-up



Follow the safety instructions (see § 2 - SAFETY INSTRUCTIONS),

■ Damper:

- Make sure the damper casing is clean and free from foreign objects. If necessary, remove any impurities using a vacuum cleaner and/or cleaning product.

■ Servomotors and manual control:

- The servomotors (optional) are fitted on the outside (See section 7.8.2 Servomotor installation)
- Actuate the servomotors in the fully closed position. Make sure the dampers are fully closed and that the blades are perfectly joined.
- Check the damper's direction of rotation (servomotor uncoupled) and correct if necessary.
- Retighten the servomotor coupling.
- If necessary, set the blades to fully closed and adjust the end of travel.
- Actuate the servomotors in the fully open position. Make sure that the blades are parallel to the air flow direction.
- If necessary, set the blades to fully open and adjust the end of travel.
- If the blades are not visible, a groove on the shaft of the dampers and extensions can be used to locate the open and closed positions of the dampers.

9 - SYSTEM START-UP



9.9.6 - Positioning of the pressure tapplings

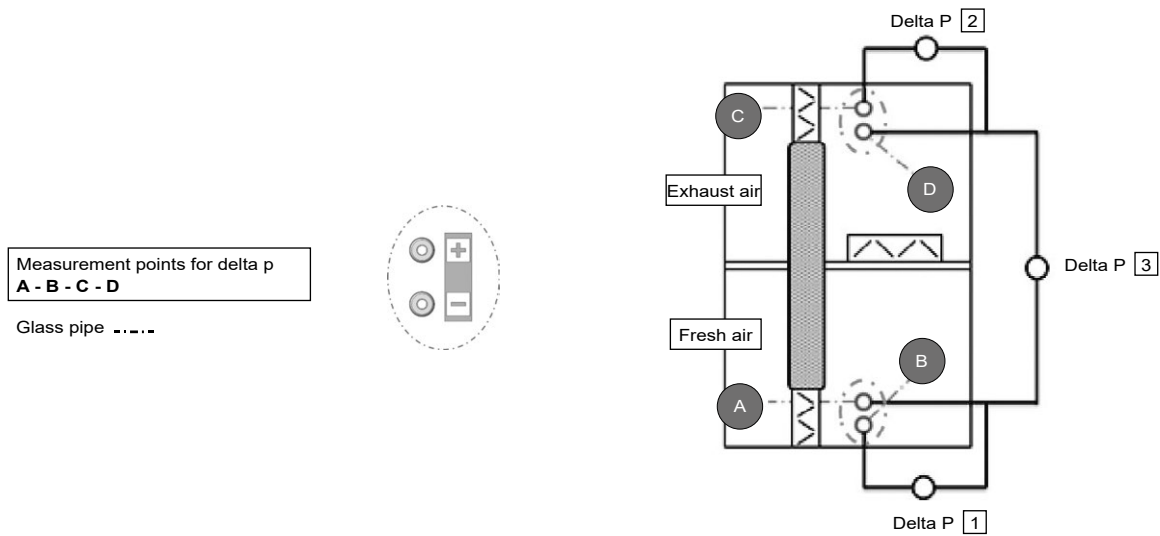

The supply for the pressure tapplings is shown in the diagram below, for all flow directions:



The pressure connections are used to measure the delta p between the three points:

- P 1 Between the front section and after the wheel and the bypass in the Fresh Air section 
- P 2 Between the front section and after the wheel and the bypass in the Exhaust Air section 
- P 3 Between the Fresh Air and Exhaust Air sections 

9.9.7 - Handling

- For certain sizes, the rotary partial heat exchanger comprises a self-contained block. This block is supplied resting on its rear surface. See connection section (see § 7.9 Heat recovery units)

9.10 - Check after start-up

■ Water flow check:

- For each pan connection to the drainage network, make sure the water drains correctly from the pan (no retention) and that the water in the siphon is still present. In the event of a problem, refer to § 7.1 Siphons.
- If the water does not drain correctly, make sure the unit is horizontal (see Installation section, § 6.3 Assembling the blocks),
- If a steam humidifier is installed, make sure there are no low points on the steam connection tubing.

■ Mechanical noise check:

In case of abnormal noise, check that:

- The transport chocks have been removed,
- The impellers are correctly centred on the sections,
- The impellers rotate freely when powered off,
- The impellers are correctly balanced,
- The impellers rotate in the correct direction,
- The belts are correctly tensioned,
- There is no vibration.

■ Air noise check:

In case of abnormal noise:

- Check the mountings of the connection ducts at the unit's inlet and outlet,
- If the noise is caused by a leak at a block connection, make sure the gasket is correctly positioned (see § 6.3 Assembling the blocks),
- If the noise is caused by a leak at the door, adjust the hinges and handles,
- If the noise is caused by air passing through a damper, make sure that the servomotors are correctly set (opening/closing), based on the site requirements,
- Incorrectly sized ducts resulting in excessive air speed may also cause this type of problem. The air duct network must therefore be balanced before a problem can be assumed on the AHU.

9 - SYSTEM START-UP

■ Hydraulic noise check:

In case of abnormal noise, check:

- The operation of the air bleed valves on the coil manifolds or the system,
- The condition of the water filters,
- The installation of the 3-way valve,
- The water flow rate value.

■ Check the current of the electrical devices (using a current clamp):

- Make sure the current values do not exceed the current values on the data plates of the various components (motors/electric heaters/etc.),
- FMAs with an inverter can only be measured on the inverter display,
- Check the phase balance (max. deviation 2%),

■ Check the activation of the safety devices. Make sure:

- The safety devices (crankcase, protective grille) are correctly secured and not in contact with moving parts,
- The door contacts cut the motor electrical supplies and the control (option),
- The DAD safety components (standalone trigger sensors for smoke detection) are operational (use the spray supplied with the DAD. See supplier manual),
- Antifreeze protection alarm: Activate this safety device by rapidly cooling the safety thermostat (aerosol can),
- Min. flow rate limit => procedure: for units with electric heaters, check this cut-off value to prevent overheating.

■ Operating readings:

- Take initial complete operating readings, including measurements of the flow rate, pressure, air/water temperature, pressure drop in the filters/recovery exchanger, voltage, current.

10 - OPERATION AND MAINTENANCE

10.1 - General recommendations for cleaning

To disinfect, use cleaning products which are compatible with the list of disinfectants approved by RKI (Robert Koch Institute) or VAH (Verbund für Angewandte Hygiene), Respect the contact times and concentrations indicated by the manufacturer.

- Do not use flammable products
- Do not use a sponge or abrasive tool
- Clean the door seals and access panels
- It is recommended to comply with the maintenance requirements according to the VDI 6022 standard (table 8)

10.2 - Filters

10.2.1 - Periodic maintenance

- Every 3 months
- Every month for ATEX units 
- Follow the instructions given in section 10.1 General recommendations for cleaning



Follow the safety instructions (see § 2 - SAFETY INSTRUCTIONS),

- The filter cells are flammable products, and the fire risk may increase depending on the elements filtered by the medium. Keep the filters away from flames.
- Mounting, cleaning and replacement of filters pose risks of allergies and irritation of the skin, airways and eyes. When working on the filters, always use suitable Personal Protective Equipment.
- The filters should be checked regularly depending on the operating conditions.



Severe fouling of the filters may pose risks to the health of occupants or the production processes.

- Maintenance phases:

1. Check the condition of the filters (fouling level, tearing, corrosion), and the sealing gaskets (except for assembly with bare runners),
Warning: even if no clogging is visible, mould or bacteria may still be present,
2. Check for mechanical jamming of the filters,
3. Clean all the components upstream of the filters and the duct networks,
4. Clean the filter support frames,
5. Check the operation of the pressure drop measuring instruments,
6. Clean the inside of the filtration box. Remove any impurities using a vacuum cleaner and/or a cleaning product,
7. Make sure there are no foreign objects inside the box,

- Replacing the filters:

- Once the maximum pressure drop recommended by the manufacturer has been reached (See the table in section 9.3 Filters),
- In case of excessive leaks, damage or corrosion,
- In case of odours, spare cells can be ordered from the unit manufacturer's distribution network. Only original parts guarantee optimal operation.

- When replacing filters:

- Take care not to damage the gaskets when disassembling fouled filters,
- Clean all the components upstream of the filters and the duct networks,
- Clean the filter support frames,
- Match the original technical and dimensional specifications of the filter cells,
- Check the filters. New filters have an expiry date, which must be observed,
- Refit the new filters and lock with the runners or the hooks depending on the assembly,
- Clean the inside of the filtration box. Remove any impurities using a vacuum cleaner and/or a cleaning product,
- Make sure there are no foreign objects inside the box.



- Disposal of filters:

- Depending on the filtration environment, the filter cells may be considered as special waste, and must comply with environmental and health regulations in force at the installation site.

10 - OPERATION AND MAINTENANCE

10.3 - Fans

10.3.1 - Direct-drive fans

Periodic maintenance

- Every 3 months
- Every month for ATEX units 
- Follow the instructions given in section 10.1 General recommendations for cleaning



Follow the safety instructions (see § 2 - SAFETY INSTRUCTIONS),

- When working inside the unit, make sure that the motors are switched off and the fans are not running.
 - Follow the instructions in § 9.4 Fans.
 - Check the motor/fan/mountings assembly for corrosion.
 - Check for noise and vibrations from the bearings.
 - Check that the fan is clean. Fouled blades may lead to imbalance and breakdown of the fan.
 - If the motor has a cooling grille, check that it is clean.
 - Remove any impurities using a vacuum cleaner and/or a cleaning product.
 - Check the protection components (grille, crankcase),
 - Check the tightness of the electrical connections (see § 7.5 Connecting the fans),
 - For plug fans, check the balance of the wheel and the deviation between the wheel and the frame (see page 24),
 - Check the flexible connections.
 - Check the anti-vibration mounts.
 - Check the tightness of all mounting bolts.

10.3.2 - Direct drive fan

- Follow the instructions and settings in § 9.4 Fans
- Bearings:
 - The maintenance frequency for the bearings depends on the fans' operating conditions.
 - Most fans have lifetime lubricated bearings.
 - Some fans have bearings with their own lubricators. Observe the frequency and type of lubricant recommended by the fan manufacturer.
- Pulleys and belts:
 - The maintenance frequency for the belts depends on the fans' operating conditions.
 - Check the belt tension and wear.
 - Check that the motor and fan pulleys are correctly aligned.
- Replacing the belts:
 - Reduce the centre distance (diagram opposite) so that the V-belt(s) can be positioned in the groove without forcing. It is forbidden to force them using a lever, screwdriver or other tool.
 - On pulleys with several grooves, if one of the belts is faulty or worn, all of the belts must be replaced simultaneously. V-belts of different makes and with different production dates must not be used in a set of belts.
 - If the fans are stopped for prolonged periods (more than three months), there is a risk of bearing damage. To prevent this, we recommend reducing the belt tension or temporarily removing the belts from the fan. When restarting the fans, the belt tension must be readjusted to the specified value. Likewise, monthly rotation is recommended to prevent the formation of a flat spot on the rollers.

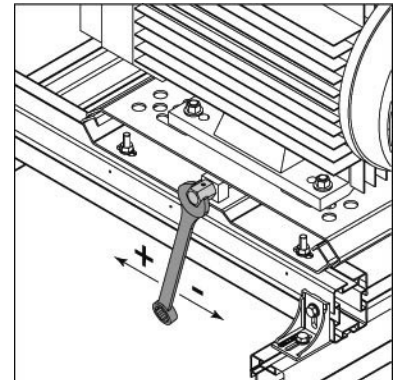

10.3.3 - Disassembling the fan motor assemblies

- When disassembling the fan motor assemblies, use suitable lifting equipment and comply with the safety standards.

10 - OPERATION AND MAINTENANCE

10.4 - Heating/cooling coil

■ Assembly and disassembly of the coil:

If the coil is located just upstream or downstream of a unit junction, first remove the connection cleats ① before removing the front face, then the retaining screws ② and the tube holders ③.

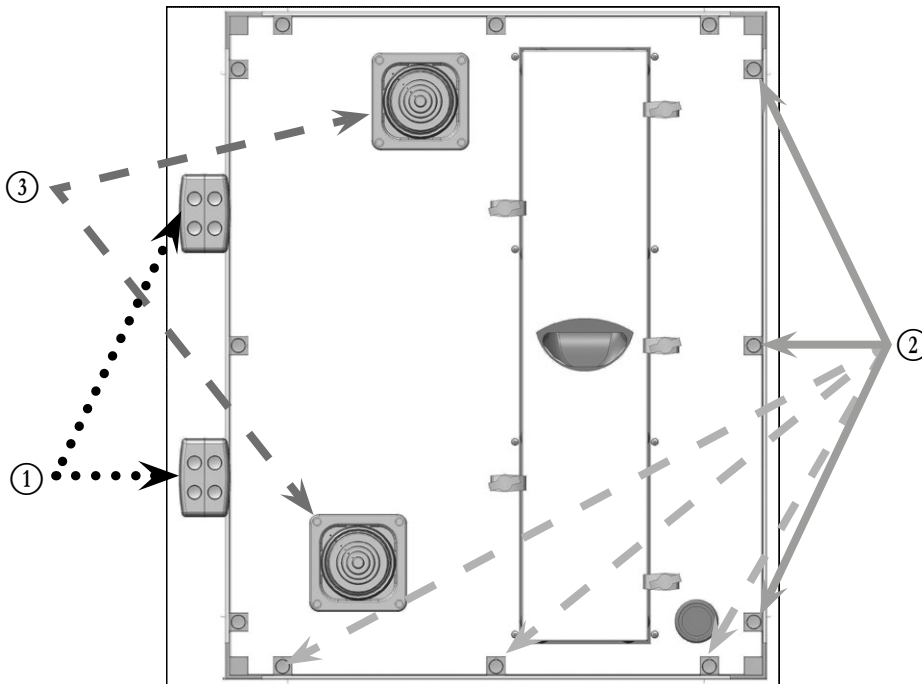

Notes:

- It is recommended that the condition of the clipped baffle gasket is checked each time the coil is removed. This must be replaced if necessary.
- If the coil is taken out, the tube holder gripper must be replaced.

10.4.1 - Cooling coil

■ Maintenance:

- Make sure the water inlet and outlet ducts are in good condition. Check the tightness of the connections and retighten if necessary.
- If the coil is not operating, we recommend bleeding it fully. Blow all the circuits with compressed air to bleed them fully. Without this additional pressure, significant amounts of fluid may remain, posing a serious risk of damage in the event of freezing (not covered by the warranty).
- If the fins are damaged, straighten them using a comb suited to the width of the fins.
- For glycol/water mix heat exchangers, check the level of frost protection using a refractometer.
- Cleanliness is a determining factor in the unit's performance, therefore carefully check the condition of the coil, the corrosion level and for any damage.
- The coils can be cleaned without being disassembled. However, if they are not easily accessible, or if the fouling level is excessive, the coils are positioned on runners and can be removed for complete cleaning or replacement.

■ Assembling and disassembling the coil:

- Remove the front panel, then the mounting screw (DETAIL A) to remove the coil.

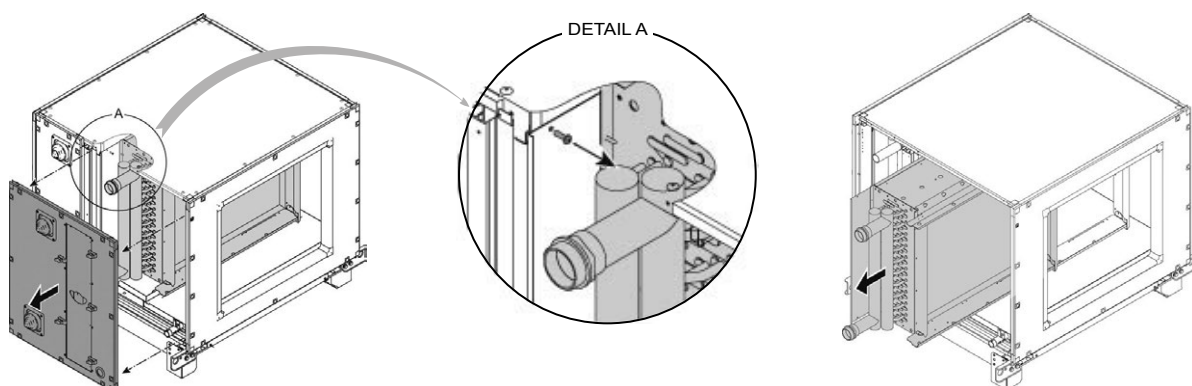

10 - OPERATION AND MAINTENANCE

■ Coil maintenance

- If the fins are damaged, straighten them using a comb suited to the width of the fins.
- Instruction in case of low fouling level (non-clogging dust or dry residue)
- Counter-flow supply air: dry air up to 30 bar.
- Where possible, periodically reversing the flow of air generated by the fans can prevent this.
- In the event of moderate fouling (moderate clogging due to dry residues, damp dust or grass, insects, etc.):
 - Use a high-pressure (HP) steam cleaner with a flat jet nozzle (25°),
 - Max. pressure 100 bar,
 - Steam: max. 140°C,
 - Min. distance between the nozzle and the fins = 200 mm,
 - Cleaning fluid: municipal water with pH neutral detergent (pH 7), Avoid alkaline detergents,
 - Flushing with clean water using the same adjustment parameters.



The use of detergent is prohibited for cleaning fins with a BLYGOLD®, ALTENA® or HERESITE® coating.

■ Prolonged downtime

- To prevent the formation of ice during prolonged downtime, fully drain the coil. Blow all the circuits with compressed air to bleed them fully. Without this additional pressure, significant amounts of fluid may remain, posing a serious risk of damage in the event of freezing (not covered by the warranty),
- Recover the water/glycol mixture in accordance with the regulations in force at the installation site.
- If the hydraulic circuit is drained for a period of more than one month, fill the entire circuit with nitrogen to prevent any risk of corrosion. Observe the maximum operating pressure values indicated in the unit's technical specifications.

10.5 - Electric heater



Follow the safety instructions (see § 2 - SAFETY INSTRUCTIONS),

■ Frequency:

- Every three months
- Every month for ATEX units 
- Follow the instructions given in section 10.1 General recommendations for cleaning

■ Maintenance:

- In case of problems or if the heaters need to be accessed, they can be removed for complete cleaning or replacement.

■ Assembling and disassembling the heater

- Remove the front panel, then the mounting screw to remove the heater.
- For units supplied with a control unit, the electrics box must be disassembled before the heater is disassembled.

■ Coil maintenance



Before carrying out any work:

- Cut the coil supplies.
- Run the ventilation until the heating elements have completely cooled to ambient temperature.
- Cut the fan supplies.

■ During maintenance:

- Check the general condition of the coil,
- Retighten the heating element connections (tightening torque 2.5 Nm),
- Check the condition of the heating elements for fouling, damage or corrosion,
- Check that the temperature limiters are operating correctly,
- Check the earth conductor,
- If necessary, clean the heating elements.



Do not use a cleaning product or cloths with detachable fibres (e.g. cotton/wool) on the heating elements.

- Make sure the electric heater box is clean and free from foreign objects
- Remove any impurities using a vacuum cleaner and/or a cleaning product,



Never activate the heaters in the absence of air flow.



ELECTRICAL DANGER: Door for directly accessing the electrical connections. Lock the door with the key once closed.

10 - OPERATION AND MAINTENANCE

- Numerous factors may lead to general overheating of the electrical components, resulting in activation of the thermostats.
- Examples:
 - Powering up without ventilation,
 - Insufficient air flow,
 - Clogged filters,
 - Reversing the fan's direction of rotation,
 - Air dampers closed.

10.6 - Steam humidifier

For the adiabatic humidifier, see the instruction manual for the adiabatic evaporative humidifier.



Follow the safety instructions (see § 2 - SAFETY INSTRUCTIONS),

10.6.1 - On the humidifier:

- Clean the humidifier once a year and replace its steam cylinder. These operations must be carried out by qualified personnel, in accordance with the manufacturer's instructions (see manual supplied with the unit),
- The information below constitutes the general rules to be followed:
 - Check and clean the water filters.
 - Check the electrical contacts and the correct operation and cleanliness of the supply and drainage solenoid valves.
 - Make sure the steam distribution is free from deposits and leaks.
 - Check the electrical current.
 - Clean all of the pipes and check their general condition (porosity, hardness),
 - If replacing the cylinder, check the condition and cleanliness of the gaskets and their faces.

10.6.2 - On the unit:

- Follow the instructions given in section 10.1 General recommendations for cleaning
- Check the condition of the rails and the pan, and the fouling level of the eliminator cells, and look for any corrosion or damage.
- The drain pan siphon (option) must be activated during commissioning or after a period of prolonged downtime.
- Clean and disinfect the siphon with a suitable product.
- Clean and disinfect the drain pans with a suitable product.
- Make sure the box is clean and free from foreign objects. Remove any impurities using a vacuum cleaner and/or a cleaning product.
- Check that the humidity sensors (option) are operating correctly.

10.6.3 - Evaporative humidifier

Refer to the manufacturer's manual.

10.7 - Damper and mixing



Follow the safety instructions (see § 2 - SAFETY INSTRUCTIONS),

- Frequency:
 - Every three months
 - Every month for ATEX units
- Follow the instructions given in section 10.1 General recommendations for cleaning
- For the dampers:
 - Check the integrity and efficiency of the protective grilles,
 - Clean the dampers, repair any damage and remove any corrosion. The blade drive shafts are mounted in the plastic bearings, which do not require maintenance,
 - Check the condition of the linkages and replace if necessary,
 - Make sure the blades are straight,
 - Check the condition of the gaskets between the blades, and that they are perfectly joined,
 - Uncouple the servomotor and make sure the blades rotate freely,
 - Retighten the servomotor coupling,
 - Actuate the dampers in the fully closed position and make sure the blades are perfectly joined,
 - Place the damper in the fully open position before restarting,
 - Remove any impurities using a vacuum cleaner and/or a cleaning product,
 - Make sure the damper box is clean and free from foreign objects.
- For the servomotors:
 - Retighten the servomotor mountings,
 - Make sure the drive (damper servomotor) reaches the end of travel positions (adjust the end limits if necessary),
- For drain pan option:
 - Clean and disinfect the drain pans with a suitable product.

10 - OPERATION AND MAINTENANCE

- For siphon option:
 - The siphon must be activated during commissioning, or after each period of prolonged downtime.
 - The siphon level must be checked periodically,
 - Operation without condensation may result in evaporation of the water contained in the siphons,
 - Clean and disinfect the siphon with a suitable product.

10.8 - Sound attenuator



Follow the safety instructions (see § 2 - SAFETY INSTRUCTIONS),

- Frequency:
 - Every three months
 - Every month for ATEX units
 - Follow the instructions given in section 10.1 General recommendations for cleaning
- Cleanliness is a determining factor in the efficiency of sound attenuators:
 - Make sure the sound attenuator box is clean and free from foreign objects. Remove any impurities using a vacuum cleaner and/or a cleaning product,
 - Clean the baffle surfaces without damaging the fabric covering the rock wool. Warning: this fabric is fragile and a maintenance vacuum cleaner may be too powerful. It may be sufficient to wipe the baffles with a cloth,
 - Check for corrosion on the baffle frames and inside the box,
 - Replace the baffles if they are worn, or if the protective fabric is torn.

10.9 - Heat recovery units

10.9.1 - Plate heat exchanger

10.9.1.1 - Plate recovery unit maintenance



Follow the safety instructions (see § 2 - SAFETY INSTRUCTIONS),

- Frequency:
 - Every three months
 - Every month for ATEX units
 - Follow the instructions given in section 10.1 General recommendations for cleaning
- Cleanliness is a determining factor in the efficiency of the unit:
 - Check the condition of the plates and the fouling level, and for any corrosion or damage,
 - Remove any impurities using a vacuum cleaner and/or a cleaning product,
 - The plates are only a few tenths of a millimetre thick. **Do not use** tools, screwdrivers, knives or abrasives for cleaning,
 - Cleaning with water is only authorised if a drain pan is present,
 - Remove any deposits of oil or grease using water with a product added to dissolve the grease.
- The siphon level must be checked periodically. Operation without condensation or prolonged downtime may result in evaporation of the water it contains.
 - Clean and disinfect the siphon with a suitable product.
 - Make sure any pressure and temperature sensors are operating correctly.
 - Clean and disinfect the drain pans with a suitable product.
 - Cleaning and maintenance of bypass dampers, refer to section 10.6 - Mixing and dampers.

10.9.2 - Rotary heat exchangers

10.9.2.1 - Rotary heat exchanger maintenance



Follow the safety instructions (see § 2 - SAFETY INSTRUCTIONS),

- Frequency:
 - Every three months
 - Every month for ATEX units
 - Follow the instructions given in section 10.1 General recommendations for cleaning
- The siphon level must be checked periodically. Operation without condensation or prolonged downtime may result in evaporation of the water it contains.
 - Clean and disinfect the siphon with a suitable product.
 - Clean and disinfect the drain pans with a suitable product.
- Check without disassembling the wheel
 - Cleanliness is a determining factor in the unit's performance, therefore check the condition of the fins, the fouling level, the corrosion level and for any damage.

10 - OPERATION AND MAINTENANCE

■ Cleaning the exchanger:

- For a low fouling level: dust removal with a vacuum cleaner is sufficient. In general, self cleaning, which results from the reversed cross flows of air, means there is no need for manual maintenance on the wheel,
- For a medium fouling level (non-clogging dry residue): blowing against the normal flow direction may be necessary (compressed air used with precautions),
- For a very high fouling level (clogging wet or greasy dust residue), use hot water and a gentle detergent,
- Check the condition of the brush seals and make sure there are no foreign objects. Adjust or replace the brush seals if necessary,
- Check the condition and tension of the belt.

■ Motor belt:

- Natural elongation of the Powerbelt and/or normal wear may require it to be retensioned. An initial inspection of the belt must be performed following the first 24/48 hours after system start-up in order to secure the wheel's rotary function. To retension the belt, simply shorten it. The correct tension is obtained by removing 1 to 2% of the nominal length. 1 to 2% corresponds to 1 link per metre of belt,

The belt is made from links that can be easily added or removed without the use of a tool. The belt can be shortened simply by twisting in order open and remove the links. For the Powerbelt, remove one link per metre of belt to obtain the optimal tension.

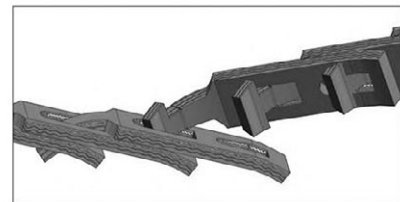
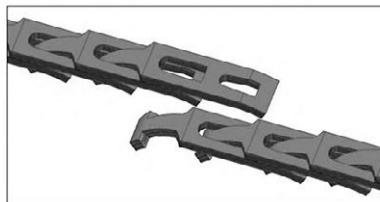
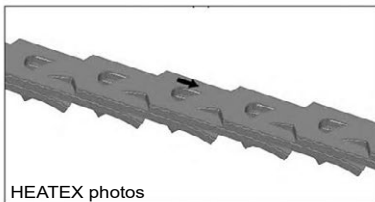

- In cases of significant wear, replace the belt (see complete procedure supplied with the belt)
 - Check that the wheel rotates freely (no friction against the frame),
 - Check for noise from the roller bearings and make sure they are not corroded. Replace if necessary.
 - If the AHU is stored or out of service for a prolonged period, the wheel must be rotated regularly to prevent a flat spot/pressure (weight of the wheel deforming the roller bearings),

■ Rotor bearing:

- The rotor bearings are usually lifetime lubricated and do not require any special lubrication. The service life of the roller bearings is between 6 and 10 years (these values may vary depending on the quality of the ambient air, which may be more or less corrosive),
- For large heat recovery units (supplied in several sections depending on the supplier), the rotor may require lubrication.
- Make sure the pressure and temperature sensors (option) are operating correctly.

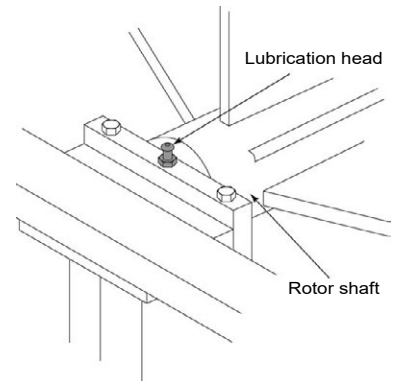

10.9.2.2 - Check requiring disassembly of the wheel

- Switch off the electrical supply
- Remove the motor access door, the upper panel (or door if variable speed), and the lock T.
- Disconnect all the supply and control wires and pull them over the roof to prevent them from being cut.
- Remove the heat recovery unit, sliding it outwards.



During removal, disconnect the condensate drain pipe located between the recovery pan on the rotary heat exchanger and the siphon located in the unit's base panel.

- Perform the maintenance operations listed in § 10.8.2.1 above.
- Refit the heat recovery unit in the reverse order to removal



Be sure to reconnect the condensate drain pipe in the siphon before pushing the heat recovery unit in fully.

10 - OPERATION AND MAINTENANCE

10.10 - List of checks and maintenance

■ Follow the instructions given in section 10.1 General recommendations for cleaning

Components		To be checked	3 months	6 months	Annual	Varies depending on use and wear
Casing	Panels	Corrosion				
		Gaskets				
Fan	Bearings	Lubrication				
		Wear (abnormal noise)				
	Plug fan	Friction/balancing				
	Belt	Alignment/Tension/Wear				
	Flexible sleeves	Tearing				
	Anti-vibration mounts	Mountings				
Motor	Motor	Electrical connections				
		Input current measurement				
		Treads				
		Cooling grille cleanliness				
Rain cover	Grille	Air flow obstruction				
		Mounting				
Filters	Filters	Tearing				
		Fouling level – Pressure difference (PD)				
	Pressure gauge	Signal check based on the PD				
Water coils	Coil	Leak				
		Air bleed				
		Fin fouling level				
		Corrosion				
	Glycol	Concentration depending on the temperature				
	Frost protection	Thermostat operation				
	Condensate pan	Corrosion/cleanliness				
	Siphon	Filling/cleanliness				
Electric heaters	Heating elements	Operation				
		Electrical connections				
	Thermostats	Operation				
Registers	Dampers	Operation, mobility and tightness				
	Servomotor	Operation and end of travel positions				
Wheel heat recovery unit	Motor	Operation				
	Belt	Tension/wear				
	Gaskets	Correct seating on the wheel				
	Fins	Fouling level/corrosion				
	Treads	Operation				
Plate recovery unit		Fouling level				
Sound attenuator		Tearing/Cleanliness				
Control		Vertical self-contained unit electrical connection tightness check				
		Measuring component operation				
Burner		See specific manual				
Humidifier		See specific manual				

10 - OPERATION AND MAINTENANCE

10.11 - Specific DIN1946-4 and VDI 6022 maintenance

To disinfect, use cleaning products which are compatible with the list of disinfectants approved by RKI (Robert Koch Institute) or VAH (Verband für Angewandte Hygiene), such as the product Indicin Pro (Ecolab), Respect the contact times and concentrations indicated by the manufacturer.

- Do not use flammable products
- Do not use a sponge or abrasive tool
- Clean the door seals and access panels
- Respect the maintenance intervals and requirements according to the VDI 6022 standard (table 8)

Maintenance must be carried out by a member of staff with at least a Category A qualification according to the VDI 6022 standard (part 4),

Other components inside the air stream:

- Glass pipes
- Grommet
- Pipe grommet
- 90° elbows for pressure tapping
- Plastic plugs for protecting screws
- Electrical wiring
- Anti-vibration mounts for fans

These components can be removed and replaced in the event of microbial or fungal infection. It is recommended that they be replaced every 12 months.

As the cables are not biologically inert, they must be monitored closely, and be subject to frequent cleaning. Should a defect become apparent, have these replaced by the authorised teams.

10.12 - Prolonged downtime

Components		Perform before or during prolonged downtime	Perform after prolonged downtime
Fan	Bearings	Monthly rotation to prevent the formation of flat areas on the treads	
	Belts	Slacken the belts	Alignment and tension
Motor	Motor		Retighten the electrical connections
	Roller bearing	Monthly rotation to prevent the formation of flat areas on the treads	
	Cooling grille		Check the cooling grille cleanliness
Water coils		Drain or add glycol	Bleed the air
Siphon		Drain	Fill
Registers	Dampers		Check for hard points in the rotation
Rotary heat exchanger	Bearing	Monthly rotation to prevent the formation of flat areas on the treads	
	Belt		Check tension
Humidifier			Check the condition of the cylinder

All the mobile parts of the unit (damper, FMA, wheel, electrical contacts) must be actuated manually to prevent the bearings from jamming or sticking (recommended every month),

All the packaging must be correctly sealed following maintenance.

11 - SPECIAL INFORMATION FOR ATEX AREAS

In accordance with directive 2014/34/EU (explosive atmospheres)

11.1 - General information

- Evaluation of the level of danger of explosion established in accordance with standards NF EN ISO 80079-36, NF EN ISO 80079-37 and EN 1127-1.
- The user must classify the various potentially explosive areas in accordance with directive 1999/92/EC.
- The units are selected and manufactured according to the type of area defined by the user.



A unit must never operate under conditions other than those it was designed for.

11.2 - Labelling

- Each unit is supplied with an ATEX Conformity Certificate; the ATEX marking is inscribed on the name plate as shown below:

- Example:  **2G/3G Ex h IIB / IIC (or IIB + H2) T., °C or TX Gb/Gc (*)**

* The labelling and the equipment integrated into the unit are adapted according to the conditions defined by the customer in the sheet completed prior to ordering.

-  : Standardised ATEX logo.
- II: Group II = surface industries.
- Equipment category (2 or 3 depending on zone 1 or 2),
- Ex h: Regulatory markings according to standard NF EN ISO 80079-36:2016
- Gas group subdivision IIA, IIB or IIC
- The IIB labelling is suitable for gas group subdivisions IIA and IIB.
- For group IIC, in the presence of hydrogen, depending on the labelling of the integrated components, the device labelling may be IIB + H2
- TX (indicates the maximum permitted surface temperature) may either:
 - Be replaced in the labelling by the temperature class given in the operating conditions defined by the customer - T1 (450 °C) to T6 (85 °C),
 - State the actual temperature (Preceded by the letter T and followed by the unit °C),
 - EPL: ("Explosion Protection Level") G for gas, followed by the level b or c depending on the category of equipment.
- For category 2, a copy of the technical conformity dossier is saved and archived for 10 years by a notified body. The archiving number for the dossier is sent to the customer.

11.3 - System start-up, maintenance

- The units must be installed and commissioned by a qualified professional.
- All the provisions set out by the current directives and standards must be respected during installation, for example, automatically linking the unit's supply to the presence of a flow rate detected by a sensor.
- In all cases, refer to the general information section of this manual, to the specific manuals for the ATEX components built into the unit and listed in the ATEX dossier, and to the specific precautions below:
 - Install the units so that the temperatures at and around the intake are between -20°C and +60°C,
 - The units and the additional metal elements must be connected electrically by a grounding cable linked to the frame,
 - Select and install all the electrical connection and control components according to the risk zone in which they will be installed,
 - All remote metal components (ducts, pipes, etc.) must be grounded, if necessary by grounding cables,
 - The motor's heat protection must be connected (see § 9 – SYSTEM START-UP)
- The installer must use all available devices to ensure that the temperature of the various elements of the installation remains below the autoignition temperature of the gas and/or the dust in question.
- If the connections for the various integrated equipment require wall feedthroughs (cable routing, sensors, etc.), these feedthroughs must be sealed to prevent any diffusion of "ATEX" atmospheres. The same is true for the connections between the various blocks which form the unit and for the connections to the ducts.
- No modifications may be made to the unit without our prior consent.
- Make sure, during assembly or maintenance operations, that no foreign objects are left inside the unit, to prevent dangerous situations from arising (see § 11.4 Information concerning the use of tools in explosive atmospheres),
- Prior to any maintenance operation, ensure that the unit is powered off.
- After each maintenance operation, check that all the removed components have been refitted and secured in their original position.
- Ensure that the ground straps are in good condition and reconnected.
- Regularly inspect the mountings on the moving parts, including the enclosures and crankcases, as well as those on moving parts such as the damper blades or filter runners.

11 - SPECIAL NOTES FOR ATEX ZONES

11.3.1 - Exchanger coils:

- The temperature of the fluids circulating in the coils must not exceed the value given on the unit's name plate.
- It must be below the surface temperature limit (or temperature class) corresponding to the ATEX atmosphere for which the unit is certified (see § 11.2 Marking),

11.3.2 - Fan motor assembly section:

- Follow the recommendations from the manufacturers of the motors and fan motor assemblies in the manuals included with the ATEX file.
- For belt pulley systems, the belt tension must be regularly adjusted and checked. A slack belt can slip and reach high temperatures. The frequency for these checks is once a week. This frequency must be adapted to the observations made during previous checks (condition of the belt, stability of the settings) and the ATEX risk.
- Only use non-flammable, antistatic electrically conductive belts adapted to the unit's ATEX atmosphere.

11.3.3 - Air filter:

- For ATEX units (in categories 2 - zone 1 - and 3 – zone 2 or 22 -), only use ATEX-certified antistatic filters, compatible with the zone and the gas and/or dust group.
- To limit the deposits of dust in the units installed in zone 22, you must:
 - Replace the filters once they are moderately fouled,
 - When replacing filters, clean the unit fully using a vacuum cleaner, in particular any components subject to high temperatures (exchanger coils, fan motor assembly, etc.),
 - Ensure that the ground straps for the filter cells are reconnected, and check that they are in good condition before restarting.

11.3.4 - Electrical connections:

- All electrical connections must be performed by qualified, ATEX-approved personnel. Under no circumstances may the manufacturer be held liable for the performance of these connections, which are outside the scope of its services.

11.3.5 - Prevention of corrosion:

- If any rust appears, sand the corroded surface with an emery cloth, clean, then protect with rustproof, anti-electrostatic paint.

11.4 - Using tools in an explosive atmosphere

- The operating managers for the installations and processes which include explosive atmospheres must provide all persons working on a site with information relating to using manual tools in complete safety. There are two different types to be taken into consideration:
 - Type A: Tools liable to only produce single sparks when used, such as screwdrivers, spanners or impact wrenches, for example,
 - Type B: Tools that generate a plume of sparks, which may be used during grinding or sawing operations.
- In zones 1 and 2 (or 22), only type A tools are permitted; use of type B tools can only be authorised if no dangerous explosive atmosphere is present within the working area.
- In zone 1, and in the presence of substances belonging to group IIC (acetylene, carbon disulphide, hydrogen) and hydrogen sulphide, ethylene oxide, carbon monoxide, if there is a risk of explosion due to the presence of these substances, the use of steel tools is prohibited unless it can be assured that no dangerous explosive atmosphere remains in the place of work whilst these tools are being used.
- Type A steel tools can be authorised in zone 22; type B steel tools can only be used if the place of work is separated and protected from the remaining zone 22 locations and if the following additional measures are taken:
 - Either any dust deposits have been removed from the working area,
 - Or there is sufficient moisture in the working area to prevent dust from being dispersed into the air and the development of smouldering fires.
- During grinding or sawing operations in zone 22 or close to such a zone, it is possible that any sparks produced could be projected large distances and thereby form glowing particles. For this reason, the other zones around the place of work must also be included in the protective measures mentioned above.
- The use of tools in zones 1, 2 and 22 must be subject to the "work permit" system.
- All other types of tools or equipment required for maintenance operations (vacuum cleaners, etc.) must be compatible with use in the ATEX zone in question. Otherwise, it must be ensured that, prior to and for the duration of any maintenance operation, the place of work is sufficiently ventilated to prevent the presence or formation of an explosive atmosphere.

11.5 - Check - Periodic inspections

11.5.1 - Unit vibration

■ Dangers:

- The vibration check detects:
 - Any wear to rotating parts. Any significant discrepancy in the vibration speeds may cause parts to come into contact with each other, which may spark an explosion; it may even cause certain parts to break with the same result.
 - An increase in the vibration speeds may also indicate that there is an accumulation of dust and an imbalance has been created. An accumulation of dust can spark an explosion, by creating areas of contact or by reducing the ignition temperature of the gas.

■ Check:

- Users must ensure that the vibration levels of the fan motor assembly remain below the standardised levels, and that there are no deviations in the vibration speed values.
- Application category BV3 according to standard ISO 14694.

■ Check frequency:

- Depending on the use (room temperature, and hourly rate of rotation of the device) and the fluid circulated (from highly charged with particles, to very clean), users must check the vibration speeds so that any discrepancy in the speed levels can be detected.
- The frequency of checks must be as follows:
 - Every 150 hours, or weekly, during the first month of installation.
 - Every 2000 hours, or every 3 months thereafter

■ Corrective actions:

- If a deviation in the vibration speed values is noted, the fan motor assembly must be stopped and inspected. If dust is found, all the areas affected must be thoroughly cleaned. If the vibration speed level is still compliant with the standardised thresholds, the fan motor assembly may return to normal operation.
- If the alarm level is reached, schedule a 2nd inspection and return to checking every 150 hours, or weekly.
- If the maximum standardised vibration thresholds are exceeded, the fan motor assembly must be stopped, a record taken, and a 2nd inspection must be performed.
- In all cases, a vibration check must be performed after the fan motor assembly is returned to normal operation.

11.5.2 - Checking the ground continuity

■ Dangers:



There is a risk of electrostatic discharge.

■ Check:

- For components fitted with straps:
 - Perform a visual inspection of the ground straps (check they are present) and check that the ground strap terminal retaining screws are correctly tightened.
 - With the unit switched off, measure the resistance between one ground strap terminal on each component and the connection terminal to the customer ground with a supply of 12 Volts. During the first check, this measurement must be noted on the maintenance sheet (see § 11 -6 Inspection sheet) as well as the reference resistance. The resistance must not exceed 25% of the reference resistance.
- If the resistance check exceeds 25% of the reference resistance:
 - Dismantle each ground strap terminal individually. Only one terminal must be disconnected at a time (this operation must be performed with the unit switched off)
 - Check that there is no area of pitting corrosion on the grounding lug or strap terminal.
 - Repeat the resistance measurement.

■ Check frequency:

- Elements ensuring ground continuity must be checked at the following intervals:
 - Every 150 hours, or weekly, during the first month of installation.
- If any irregularity is detected during this period of observation:
 - Every 5000 hours, or annually thereafter.

■ Corrective actions:

In the following cases:

- Ground strap terminal retaining screws incorrectly tightened:
 - Retighten the screws, if the problem persists.
- Areas of pitting corrosion detected on the grounding lug
 - Lightly grind the surface of the lug and carefully check the condition of the ground strap terminal.
- Areas of pitting corrosion detected on the ground strap
 - Replace the ground strap.

11 - SPECIAL NOTES FOR ATEX ZONES

11.6 - ATEX control sheet

Date	Check or Test performed	Initial values	Number of hours of service	Type of operation	Comments	Approved	Failed
	Vibration speed on fan and motor bearings. (According to standard ISO 14694)						
	Ground strap between motor and fan						
	Other strap						
	Other strap						
	Other strap						
	Ground strap between the user ground and the unit						
	Fan inspection						
	Motor current check						
	Inspection of other components						
	Inspection of other components						
	Inspection of other components						
	Ambient temperature						
	Accumulation of dust on the fan and other unit components						
	Ground continuity check. Reference resistance in Ohms.						
	Other						
	Other						

12 - FINAL SHUTDOWN

12.1 - Shutting down



- Separate the units from their energy sources, allow them to cool then drain them completely.

12.2 - Recommendations for disassembly

- Handling operations must be carried out by qualified personnel using PPE. The PPE must comply with the safety rules.
- It is forbidden to reuse lifting accessories.
- Sort the components according to their material for recycling or disposal, in accordance with regulations in force.
- Check whether any part of the unit can be recycled for another purpose.

12.3 - Materials to be recovered for recycling



- Galvanised carbon steel
- Stainless steel
- Copper



- Aluminium
- Plastics
- Glass wool (insulation)
- Electrical equipment.
- The electronic board can be recycled by a recovery company (gold, silver),

12.4 - Fluids to be recovered for recycling

- In accordance with regulations.
- MEG, MPG. Thermal fluid
- Any type of refrigerant
- Compressor oil

12.5 - Waste electrical and electronic equipment (WEEE)

- At the end of its life, this equipment must be disassembled and contaminated fluids removed by professionals and processed via approved channels for electrical and electronic equipment (WEEE),
- In France, a partnership has been established with companies for the collection and recovery of professional waste governed by European Directive WEEE 2012/19/EU. This partnership simplifies the mandatory administrative procedures and ensures that old equipment is recovered via an official, structured channel. In terms of renovation work in France (mainland and overseas), for every new unit installed, our partner will collect and dismantle your existing equipment. Contact us for DETAILS of our partners.
- For other countries, please refer to the legislation in force and the specific solutions available to ensure your waste is processed legally.

The quality management system of this product's assembly site has been certified in accordance with the requirements of the ISO 9001 standard (latest current version) after an assessment conducted by an authorized independent third party.

The environmental management system of this product's assembly site has been certified in accordance with the requirements of the ISO 14001 standard (latest current version) after an assessment conducted by an authorized independent third party.

The occupational health and safety management system of this product's assembly site has been certified in accordance with the requirements of the ISO 45001 standard (latest current version) after an assessment conducted by an authorized independent third party.

Please contact your sales representative for more information

Carrier S.C.S, Rte de Thil - 01120 Montluel, France.

Manufacturer reserves the right to change any product specifications without notice.

Printed in the European Union.