

A1 - A3	MODULE MAITRE A MICROPROCESSEUR	A1 - A3	MICROPROCESSOR-BASED MASTER MODULE	A1 - A3	HAUPTMODUL
A2	AFFICHEUR	A2	DISPLAY	A2	BEDIENUNGS- UND ANZEIGE-MODUL
A148	PASSERELLE CCN-JBUS	A148	J-BUS BOARD	A148	J-BUS SCHNITTSTELLE RS232/RS485
BP1-BP2	TRANSDUCTEUR DE PRESSION REFOULEMENT CIRCUIT A-B	BP1-BP2	DISCHARGE PRESSURE TRANSDUCER, CIRCUIT A-B	BP1-BP2	MESSWANDLER VERDICHUNGSDRUCK, KREISLAUF A-B
BP3-BP4	TRANSDUCTEUR DE PRESSION ASPIRATION CIRCUIT A-B	BP3-BP4	SUCTION PRESSURE TRANSDUCER. CIRCUIT A-B	BP3-BP4	MESSWANDLER SAUGDRUCK, KREISLAUF A-B
BP90.1-BP90.2	TRANSDUCTEUR DE PRESSION POMPE HYDRAULIQUE	BP90.1-BP90.2	WATER PUMP PRESSURE TRANSDUCER	BP90.1-BP90.2	DRUCKMESSWANDLER ULIKPUMPE
EC1-EC2-EC3	COMPRESSEUR CIRCUIT A	EC1-EC2-EC3	COMPRESSOR CIRCUIT A	EC1-EC2-EC3	VERDICHTER KREISLAUF A
EC3-EC4	COMPRESSEUR CIRCUIT B	EC3-EC4	COMPRESSOR CIRCUIT B	EC3-EC4	VERDICHTER KREISLAUF B
ED1-ED2	DETENDEUR	ED1-ED2	EXPANSION VALVE	ED1-ED2	ELEKTRONISCHES EXPANSIONSVENTIL
EH40	RECHAUFFEUR BALLON TAMPON	EH40	BUFFER TANK HEATER	EH40	PUFFERSPEICHERHEIZUNG
EH41	RECHAUFFEUR EVAPORATEUR	EH41	EVAPORATOR HEATER	EH41	VERDAMPFERHEIZUNG
EH90	RECHAUFFEUR CIRCUIT D'EAU EVAPORATEUR	EH90	EVAPORATOR WATER CIRCUIT HEATING ELEMENT	EH90	HEIZUNG IM VERDAMPFER-WASSERKREISLAUF
EH90A	RECHAUFFEUR CIRCUIT D'EAU EVAPORATEUR AUXILIAIRE	EH90A	AUXILIARY EVAPORATOR WATER CIRCUIT HEATING ELEMENT	EH90A	ZUSATTHEIZUNG IM VERDAMPFER-WASSERKREISLAUF
EH90B	RECHAUFFEUR CIRCUIT BALLON TAMPON	EH90B	BUFFER TANK CIRCUIT HEATERS	EH90B	BEGLEITHEIZUNG SPEICHERHEIZUNGSKREIS
EH100	RECHAUFFEUR BOITE ELECTRIQUE	EH100	ELECTRICAL BOX HEATER	EH100	VORWARMER HINKT ELEKTRISCH
EH141/EH141A-EH142	RECHAUFFEUR ANTI FORMATION DE GLACE	EH141/EH141A-EH142	COIL HEATER	EH141/EH141A-EH142	FROSTSCHUTZ HEIZUNG
EH1C ... EH4C	RECHAUFFEUR CARTER COMPRESSEUR	EH1C...EH4C	COMPRESSOR HEATER	EH1C...EH4C	KURBELWANNENHEIZUNG VERDICHTER
EP90 - EP90A	POMPE A EAU	EP90 - EP90A	WATER PUMP	EP90 - EP90A	WASSER PUMPE
EV11 - EV13	VENTILATEUR CONDENSEUR	EV11 - EV13	CONDENSER FAN	EV11 - EV13	VERFLUESSIGERVERVENTILATOR
FU - FUA	PROTECTION CIRCUIT CONTROLE	FU - FUA	CONTROL FUSE PROTECTION	FU - FUA	SCHMELZBARER SCHUTZ KONTROLLIERT
FU1...FU4	PROTECTION CIRCUIT COMPRESSEUR	FU1...FU4	COMPRESSOR CIRCUIT PROTECTION	FU1 ... FU4	SCHUTZSCHALTER VERDICHTER
GS1-GS2-GS3-GS4	DEMARREUR COURANT REDUIT COMPRESSEUR	GS1-GS2-GS3-GS4	SOFT START DEVICE, COMPRESSOR	GS1-GS2-GS3-GS4	SANFTANLAUFREGLER, VERDICHTER
GS11 - GS13	VARIATEUR DE VITESSE MOTEUR VENTILATEUR CONDENSEUR	GS11 - GS13	CONDENSER FAN MOTOR VARIABLE SPEED DRIV	GS11 - GS13	DREHZAHNREGLER VERFLUESSIGERVERVENTILATOR-MOTOR
GS90	VARIATEUR DE VITESSE MOTEUR POMPE	GS90	PUMP MOTOR VARIABLE SPEED DRIVE	GS90	SCHMELZBARER SCHUTZ KONTROLLIERT
K41	RELAIS COMMANDE RECHAUFFEUR	K41	HEATER RELAY	K41	STEUERRELAIS HEIZUNG
KM1 ... KM4	CONTACTEUR COMPRESSEUR	KM1 ... KM4	CONTACTOR COMPRESSOR	KM1 ... KM4	SCHUETZ VERDICHTER
KM11...KM14	CONTACTEUR VENTILATEUR CONDENSEUR	KM11...KM14	CONDENSER FAN CONTACTOR	KM11...KM14	SCHUETZ VERFLUESSIGERVERVENTILATOR
KML1-2	CONTACTEURSECURITE COMPRESSEURS	KML1-2	CONTACTOR SECURITY COMPRESSORS	KML1-2	CONTACTOR SICHERHEITSKOMP RESSOREN
KM90 - KM90A	CONTACTEUR POMPE EVAPORATEUR	KM90 - KM90A	EVAPORATOR PUMP CONTACTOR	KM90 - KM90A	SCHUETZ VERDAMPFERPUMPE
QF	DISJONCTEUR CIRCUIT CONTROLE ET RECHAUFFEURS	QF	CIRCUIT BREAKER	QF	SCHUTZSCHALTER
QM11 ... QM13	PROTECTION CIRCUIT VENTILATEURS	QM11 ... QM13	VENTILATOR CIRCUIT PROTECTION	QM11 ... QM13	SCHUTZSCALTER VERFLUESSIGERVERVENTILATOR
QM90	PROTECTION CIRCUIT POMPES	QM90	WATER PUMP CIRCUIT PROTECTION	QM90	SCHUTZSCHALTER KALTWASSERPUMPE
QS100	INTERRUPTEUR GENERAL	QS100	GENERAL DISCONNECT SWITCH	QS100	HAUPT-TRENNSCHALTER
RT1	SONDE DE TEMPERATURE SORTIE EAU EVAPORATEUR	RT1	EVAPORATOR LEAVING WATER TEMPERATURE SENSOR	RT1	TEMPERATURFUEHLER VERDAMPFER-KALTWASSER-AUSTRITT
RT2	SONDE DE TEMPERATURE ENTREE EAU EVAPORATEUR	RT2	EVAPORATOR ENTERING WATER TEMPERATURE SENSOR	RT2	TEMPERATURFUEHLER VERDAMPFER-KALTWASSER-EINTRITT
RT10	SONDE DE TEMPERATURE AIR AMBIANT OU EXTERIEUR	RT10	AMBIENT OR OUTSIDE AIR TEMPERATURE SENSOR	RT10	UMGEBUNGS- ODER AUSSENLUFT- TEMPERATURFUEHLER
RT11A-RT12A	SONDE EQUILIBRAGE BATTERIE	RT11/A-RT12/A	DEFROST TEMPERATURE SENSOR	RT11/A-RT12/A	FÜHLER ABTAUUNG
RT31-RT32-RT41	SONDE DE TEMPERATURE	RT31-RT32-RT41	TEMPERATURE SENSOR	RT31-RT32-RT41	TEMPERATUR SENSOR
RT100	SONDE DE T° SORTIE EAU COMMUNE EVAPORATEUR MAITRE-SUIVEUR	RT100	EVAPORATOR COMMUN LEAVING WATER T° SENSOR LEAD-LAG	RT100	FÜHLER GEMEINSAME KALTWASSERAUSTRITTS-T° LEAD-LAG
SP90F	DETECTEUR DEBIT D'EAU POMPE EVAPORATEUR	SP90F	EVAPORATOR PUMP FLOW SWITCH	SP90F	STROMUNGSWAECHTER KALTWASSER
SP101F-SP102F	PRESSOSTAT HAUTE PRESSION DE SECURITE	SP101F-SP102F	HIGH PRESSURE SAFETY SWITCH	SP101F-SP102F	HOCHDRUCK-SICHERHEITS-SCHALTER
ST100	THERMOSTAT DE REGULATION VENTILATION COFFRET ELECTRIQUE	ST100	ELECTRICAL BOX FAN CONTROL THERMOSTAT	ST100	ELEKTRISCHER BOX LÜFTER-STEUERTHERMOSTA
ST101F	DEFAUT COFFRET ELECTRIQUE	ST101F	ELECTRICAL BOX FAILURE	ST101F	ELEKTRISCHER KASTENFEHLER
TC	TRANSFORMATEUR CIRCUIT CONTROLE	TC	CONTROL CIRCUIT TRANSFORMER	TC	TRANSFORMATOR STEUERSTROMKREIS
YV41 -YV42	VANNE D'INVERSION DE CYCLE	YV41 - YV42	CIRCUIT CYCLE REVERSAL VALVE	YV41 - YV42	KREISLAUF UMKEHRVENTIL
X100	BORNIER ALIMENTATION GENERALE	X100	GENERAL TERMINAL POWER	X100	BORNIER ALLGEMEINE ERNAHRUNG
ZGS11 - 13	FILTRE CEM VENTILATEUR	ZGS11 - 13	EMC FAN FILTER	ZGS11 - 13	FILTER CEM VENTILATOR
ZGS90	FILTRE CEM POMPE	ZGS90	EMC PUMP FILTER	ZGS90	CEM-FILTER PUMPT

SCHEMA SIMPLIFIE
SIMPLIFIED WIRING
VEREINFACHTES SCHEMA

SEMPLIFICATI COLLEGAMENTI
SIMPLIFICADO CABLEDO

LD/ILD 150R -> 600R



01/04/2022

1

00DCG000341500

C

A1 - A3 MODULO PRINCIPALE A MICROPROCESSORE
 A2 DISPLAY
 A148 CHEDA CCN-J BUS
 BP1-BP2 TRASDUTTORE DELLA PRESSIONE DI MANDATA, CIRCUITO A-B
 BP3-BP4 TRASDUTTORE DELLA PRESSIONE DI ASPIRAZIONE. CIRCUITO A-B
 BP90.1-BP90.2 TRASDUTTORE PRESSIONE USCITA ACQUA POMPA
 EC1-EC2-EC3 COMPRESSORE, CIRCUITO A
 EC3-EC4 COMPRESSORE, CIRCUITO B
 ED1-ED2 VALVOLA ELETTRONICA DESPANSIONE
 EH40 RISCALDATORE SERBATOIO DI ACCUMULO
 EH41 ELETTORISCALDATORE DELL'EVAPORATORE
 EH90 RISCALDATORE CIRCUITO ACQUA
 EH90A ELEMENTO RISCALDANTE AUSILIARIO DEL CIRCUITO IDRICO EVAPORATORE
 EH90B RISCALDATORI CIRCUITO SERBATOUI DI ACCUMULO
 EH100 RADIATORE ZOPPICA ELETTRICO
 EH141/EH141A-EH142 RISCALDATORE BATTERIA
 EHC...EH4C RISCALDATORE CARTER COMPRESSORE
 EP90 - EP90A POMPA ACQUA
 EV11 ... EV13 VENTILATORE DEL CONDENSATORE
 FU - FUA PROTEZIONE CIRCUITO CONTROLLA
 FU1...FU4 MAGNETOTERMICO CIRCUITO AUSILIARIO, CIRCUITO B
 GS1-GS2-GS3-GS4 AVVIAMENTO A CORRENTE RIDOTTA, COMPRESSORE
 GS11 - GS13 VARIATORE DI VELOCITA DEL MOTORE VENTILATORE
 GS90 DISPOSITIVO DE ARRANQUE A TENSION REDUCIDA
 K41 RELE COMANDA RADIATORE
 KM1 ... KM4 TELERUTTORE, COMPRESSORE
 KM11... KM14 TELERUTTORE DEL VENTILATORE DEL CONDENSATORE
 KML1-2 COMPRESSORI SICUREZZA DEL CONTATTORE
 KM90 - KM90A TELERUTTORE DELLA POMPA DELL'EVAPORATORE
 QF INTERRUPTORE MAGNETOTERMICO, CIRCUITO
 QM11 ... QM13 MAGNETOTERMICO DEL VENTILATORE DEL CONDENSATORE
 QM90 MAGNETOTERMICO DEL VENTILATORE DELLA POMPA ACQUA AVAPORATORE
 QS100 SEZIONATORE GENERALE
 RT1 SONDA DI TEMPERATURA ACQUA USCITA EVAPORATORE
 RT2 SONDA DI TEMPERATURA ACQUA ENTRATA EVAPORATORE
 RT10 SONDA TEMPERATURA ESTERNA O AMBIENTE
 RT11/A-RT12/A SONDA DI SBRINAMENTO
 RT31-RT32-RT41 SENSORE AWOOLGIMENTI
 RT100 SENSORE ACQUA IN USCITA COMUNE (MASTER/SLAVE)
 SP90F FLUSSOSTATO POMPA EVAPORATORE
 SP101F-SP102F PRESSOSTATO DI ALTAX
 TC TRASFORMATORE DEL CIRCUITO DI CONTROLLO
 YV41 - YV42 VALVOLA D'INVERSIONE
 X100 BORNIER ALIMENTAZIONE GENERALE
 ZGS11 - 13 FILTRO CEM VENTILATORE
 ZGS90 FILTO CEM POMPA

A1 - A3 MODULO PRINCIPAL BASADO EN MICROPROCESADOR
 A2 PANTALLA
 A148 TARJETA J BUS
 BP1-BP2 TRANSDUCTOR DE PRESION DE DESCARGA, CIRCUITO A-B
 BP3-BP4 TRANSDUCTOR DE PRESION DE ASPIRACION, CIRCUITO A-B
 BP90.1-BP90.2 TRANSDUCTOR DE PRESION BOMBEA HIDRAULICA
 EC1-EC2-EC3 COMPRESOR, CIRCUITO A
 EC3-EC4 COMPRESOR, CIRCUITO B
 ED1-ED2 VALVULA DE EXPANSION ELECTRONICA
 EH40 CALENTADOR DEPOSITO DE INTERCIA
 EH41 CALENTADOR DEL EVAPORADOR
 EH90 CALENTADOR DEL CIRCUITO DE AGUA DEL EVAPORADOR
 EH90A ELEMENTO DE CALEFACCION AUXILIAR DEL CIRCUITO DE REFRIGERACION DEL AGUA DEL EVAPORADOR
 EH90B CALENTADORES CIRCUITO DEPOSITO DE INERCIA
 EH100 CALENTADOR COJEA ELECTRICO
 EH141/EH141A-EH142 CALENTADOR DE LA BATERIA
 EHC...EH4C CALENTADOR DE CARTER DEL COMPRESOR
 EP90 - EP90A BOMBA DE AGUA
 EV11 ... EV13 VENTILADOR DEL CONDENSADOR
 FU - FUA PROTECCION CIRCUITO CONTROLLA
 FU1...FU4 INTERRUPTOR DEL COMPRESOR
 GS1-GS2-GS3-GS4 DISPOSITIVO DE ARRANQUE A TENSION REDUCIDA, COMPRESOR
 GS11 - GS13 VARIADOR DE VELOCIDAD DEL MOTOR DEL VENTILADOR DEL CONDENSADOR
 GS90 DISPOSITIVO DE ARRANQUE A TENSION REDUDA
 K41 ENLACE ENCARGA CALENTADOR
 KM1 ... KM4 CONTACTOR, COMPRESOR
 KM11 ... KM14 CONTACTOR DEL VENTILADOR DEL CONDENSADOR
 KML1-2 COMPRESORES DE SEGURIDAD PARA CONTACTORES
 KM90 - KM90A CONTACTOR DE LA BOMBA DEL EVAPORADOR
 QF DISYUNTOR AUTOMATICO,
 QM11 ... QM13 INTERRUPTOR DE PROTECCION
 QM90 INTERRUPTOR DE LA BOMBA DE AGUA DEL EVAPORADOR
 QS100 INTERRUPTOR GENERAL
 RT1 SONDA DE TEMPERATURA DE SALIDA DEL AGUA DEL EVAPORADOR
 RT2 SONDA DE TEMPERATURA DE ENTRADA DEL AGUA AL EVAPORADOR
 RT10 SONDA DE TEMPERATURA AMBIENTE O DEL AIRE EXTERIOR
 RT11/A-RT12/A SONDA DE DESESCARCHE
 RT31-RT32-RT41 SONDA DE TEMPERATURA
 RT100 SENSOR DE TEMPERATURA DE LA SALIDA COMUN DE AGUA DEL EVAPORADOR
 SP90F INTERRUPTOR DE FLUJO DE AGUA DE LA BOMBA DEL EVAPORADOR
 SP101F-SP102F PRESOSTATO DE ALTA PRESION
 TC TRANSFORMADOR DEL CIRCUITO DE CONTROL
 YV41 - YV42 VALVULA DE INVERSION DE CICLO
 X100 BORNIER ALIMENTACION GENERAL
 ZGS11 - 13 FILTRO CEM VENTILADOR
 ZGS90 FILTRO CEM BOMBEA

SCHEMA SIMPLIFIE
 SIMPLIFIED WIRING
 VEREINFACHTES SCHEMA

SEMPLIFICATI COLLEGAMENTI
 SIMPLIFICADO CABLEDO

LD/ILD 150R -> 600R

	01/04/2022	2
00DCG000341500		C

RACCORDEMENTS CONTROLE CLIENT

1	MARCHE / ARRET A DISTANCE
2	SELECTION POINT DE CONSIGNE
3	LIMITATION DE CAPACITE #1
4	LIMITATION DE CAPACITE #2
5	ASSERVISSEMENT CLIENT/DEBIT D'EAU
6	COMMANDE CHAUD - FROID A DISTANCE
7	EN FONCTIONNEMENT
8	ALARME
11	CHAUDIERE
12	DESURCHAUFFEUR
13	RESISTANCE DE CHAUFFE 1
14	RESISTANCE DE CHAUFFE 2
15	RESISTANCE DE CHAUFFE 3
16	RESISTANCE DE CHAUFFE 4
17	COMMANDE POMPE EXTERNE PAR SIGNAL 0-10V

OPTIONS ET ACCESSOIRES

UNITE TRES BASSE TEMPERATURE
TRES HAUTE PRESSION DISPONIBLE
TRES BAS NIVEAU SONORE
TEMPERATURE AMBIANTE ELEVEE
MOTEUR EC
DEMARRAGE A COURANT REDUIT
FONCTIONNEMENT REFROIDISSEMENT TOUTE L'ANNEE -20°C
RECHAUFFEUR D'EVAPORATEUR
RECHAUFFEUR MODULE HYDRAULIQUE
RECHAUFFEUR MODULE HYDRAULIQUE & BALLON TAMPON
DESURCHAUFFEUR
SONDE COMMUNE EAU FROIDE (DUPLEX)
MODULE HYDRAULIQUE AVEC POMPE SIMPLE HAUTE PRESSION SANS VASE D'EXPANSION
MODULE HYDRAULIQUE AVEC POMPE DOUBLE HAUTE PRESSION SANS VASE D'EXPANSION
MODULE HYDRAULIQUE AVEC POMPE SIMPLE BASSE PRESSION SANS VASE D'EXPANSION
MODULE HYDRAULIQUE AVEC POMPE DOUBLE BASSE PRESSION SANS VASE D'EXPANSION
MODULE HYDRAULIQUE AVEC POMPE SIMPLE HAUTE PRESSION VITESSE VARIABLE
MODULE HYDRAULIQUE AVEC POMPE DOUBLE HAUTE PRESSION VITESSE VARIABLE
MODULE HYDRAULIQUE AVEC POMPE SIMPLE BASSE PRESSION VITESSE VARIABLE
MODULE HYDRAULIQUE AVEC POMPE DOUBLE BASSE PRESSION VITESSE VARIABLE
UNITE HAUTE TEMPERATURE AMBIANTE
UNITE HAUTE TEMPERATURE AMBIANTE
BUS COMMUNICATION LON
BUS COMMUNICATION BACNET
CHAUDIERE
STAGE ELECTRIQUE
DETECTEUR DE FUIITE REFRIGERANT

CUSTOMER CONTROL CONNECTIONS

1	REMOTE ON / OFF
2	REMOTE SETPOINT SELECT
3	DEMAND LIMIT #1
4	DEMAND LIMIT #2
5	FLOW SWITCH/ INTERLOCK SWITCH
6	HEAT/COOL SELECT
7	RUNNING
8	ALARME/ALERTE
11	BOILER
12	DESUPERHEATER SWITCH
13	ELECTRICAL HEATER STAGE 1
14	ELECTRICAL HEATER STAGE 2
15	ELECTRICAL HEATER STAGE 3
16	ELECTRICAL HEATER STAGE 4
17	EXTERNAL PUMP COMMAND BY 0-10V SIGNAL

ACCESSORIES AND OPTIONS

VERY LOW TEMPERATURE UNIT
XTRA FAN
XTRA LOW NOISE
HIGH AMBIENTE TEMPERATURE
EC MOTOR
SOFT START
ALL YEAR ROUND COOLING OPERATION DOWN TO-20°C
EVAPORATOR HEATER
HYDRONIC MODULE HEATER
EXCHANGER & HYDRAULIC FROST PROTECTION
DESUPERHEATER
DUPLEXING
HIGH PRESSURE HYDRONIC KIT WITH SINGLE PUMP WITHOUT EXPANSION VESSEL
HIGH PRESSURE HYDRONIC MODULE WITH TWIN PUMP WITHOUT EXPANSION VESSEL
LOW PRESSURE HYDRONIC KIT WITH SINGLE PUMP WITHOUT EXPANSION VESSEL
LOW PRESSURE HYDRONIC KIT WITH TWIN PUMP WITHOUT EXPANSION VESSEL
HIGH PRESSURE HYDRONIC KIT WITH VARIABLE SPEED SINGLE PUMP
HIGH PRESSURE HYDRONIC KIT WITH VARIABLE SPEED TWIN PUMP
LOW PRESSURE HYDRONIC KIT WITH VARIABLE SPEED SINGLE PUMP
LOW PRESSURE HYDRONIC KIT WITH VARIABLE SPEED TWIN PUMP
HIGH SEASONAL EFFICIENCY
HIGH SEASONAL EFFICIENCY
BUS COMMUNICATION LON
BUS BACNET
BOILER
ELECTRICAL HEAT STAGE
LEAK DETECTION

SCHEMA SIMPLIFIE
SIMPLIFIED WIRING
VEREINFACHTES SCHEMA

SEMPLIFICATI COLLEGAMENTI
SIMPLIFICADO CABLEDO

LD/ILD 150R -> 600R

	01/04/2022	3
00DCG000341500		C

OPTIONS ET ACCESSOIRES

FILTRE CEM VARIATION VITESSE VENTILATEUR CONDENSEUR
FILTRE CEM VARIATION VITESSE POMPE
MODULE BALLON TAMPON
MODULE BALLON TAMPON 16KW
MODULE BALLON TAMPON 31KW
MODULE BALLON TAMPON 45KW
GESTION AERO FREE COOLING

ACCESSORIES AND OPTIONS

REINFORCED ECM FILTRATION FOR VARIABLE SPEED FAN
REINFORCED ECM FILTRATION FOR VARIABLE SPEED PUMP
WATER BUFFER TANK MODULE
WATER BUFFER TANK MODULE WITH 16KW
WATER BUFFER TANK MODULE WITH 31KW
WATER BUFFER TANK MODULE WITH 45KW
AERO FREE COOLING MANAGEMENT

SCHEMA SIMPLIFIE
SIMPLIFIED WIRING
VEREINFACHTES SCHEMA

SEMPPLICATI COLLEGAMENTI
SIMPLIFICADO CABLEDO

LD/ILD 150R -> 600R

	01/04/2022	4
00DCG000341500		C

KUNDEN STEUERKLEMMLEISTE

- 1 FERNBEDIENUNG EIN / AUS
- 2 FERNUMSCHALTUNG HEIZEN - KÜHLEN
- 3 LEISTUNGS-AUFNAHMEBEGRENZUNG #1
- 4 LEISTUNGS-AUFNAHMEBEGRENZUNG #2
- 5 SCHALTER DES FLUSS-SWITCH/INTERLOCK
- 6 FERNHITZE/KÜHLEN AB
- 7 LAUFEN
- 8 ALARME / ALERT
- 11 ANSTEUERUNG BOILER
- 12 VON-UBERHITZER
- 13 ELEKTROWARME-STADIUM 1
- 14 ELEKTROWARME-STADIUM 2
- 15 ELEKTROWARME-STADIUM 3
- 16 ELEKTROWARME-STADIUM 4
- 17 EXTERNAL PUMP COMMAND BY 0-10V SIGNAL

ZUBEHOR UND OPTIONS

MASCHINE SEHR TIEFE TEMPERATUR
VERFLUESSIGERVENTILLATOR MIT BESONDERSHOHER EXTERNE PRESSUNG LIEFERBAR
NIEDRIGER GERAUSCHPEGEL

SANFTANLAUFREGLER
WINTERANLAUF

VERDAMPFERHEIZUNG

HEIZUNG IM VERDAMPFER WASSER KREISLAUF

HEIZUNG IM VERDAMPFER WASSER KREISLAUF

UBERHITZER

GEMEINSAME SONDE KALTES WASSER

HYDRONIK MODUL MIT PUMPE EINFACHER HOHER DRUCK OHNE AUSDEHNUNGSGEFAB

HYDRONIK MODUL MIT PUMPE DOPPELTER HOHER DRUCK OHNE AUSDEHNUNGSGEFAB

HYDRONIK MODUL MIT PUMPE EINFACHERNIEDRIGER DRUCK OHNE AUSDEHNUNGSGEFAB

HYDRONIK MODUL MIT PUMPE DOPPELTER NIEDRIGER DRUCK OHNE AUSDEHNUNGSGEFAB

HYDRONIK MODUL MIT PUMPE EINFACHER HOHER DRUCK OHNE AUSDEHNUNGSGEFAB

HYDRONIK MODUL MIT PUMPE DOPPELTER HOHER DRUCK OHNE AUSDEHNUNGSGEFAB

HYDRONIK MODUL MIT PUMPE EINFACHER HOHER DRUCK OHNE AUSDEHNUNGSGEFAB

HYDRONIK MODUL MIT PUMPE DOPPELTER HOHER DRUCK OHNE AUSDEHNUNGSGEFAB

LON

BACNET

KESSEL

ELEKTRISHES PRAKTIKUM

LECKERKENNUNG

COLLEGAMENTI DI CONTROLLO PER CLIENTE

- 1 CONTROLLO REMOTO ON/OFF
- 2 SELEZIONE AFFATTO DI CONSEGNA
- 3 LIMITAZIONE DI CAPACITA 1
- 4 LIMITAZIONE DI CAPACITA 2
- 5 CONTROLLO CLIENTE / FLUSSO D'ACQUA
- 6 COMANDO CALDO / FREDDO A DISTANZA
- 7 IN FUNZIONAMENTO
- 8 ALLARME / ALLARME
- 11 CALDAIA
- 12 SURRISCALDATORE
- 13 RESISTENZA DI RISCALDAMENTO 1
- 14 RESISTENZA DI RISCALDAMENTO 2
- 15 RESISTENZA DI RISCALDAMENTO 3
- 16 RESISTENZA DI RISCALDAMENTO 4
- 17 EXTERNAL PUMP COMMAND BY 0-10V SIGNAL

ACCESSORI ED OPZIONI

UNIT ABASSISSIMA TEMPERATURA
PRESSIONE SPECIALE DISPONIBILE SUI VENTILATORI DEL CONDENSATORE
OPZIONE SILENZIATA

AVVIAMENTO A CORRENTE RIDOTTA

AVVIAMENTO INVERNALE

CALENTADOR DEL EVAPORADOR

RISCALDATORE CIRCUITO ACQUA

RISCALDATORE CIRCUITO ACQUA

SURRISCALDATORE

PREDISPOSIZIONE PER DUPLEX

MODULO IDRAULICO CON POMPA SEMPLICE ALTA PRESSIONE SENZA FANGO D'ESPANSIONE

MODULO IDRAULICO CON POMPA DOPPIA ALTA PRESSIONE SENZA FANGO D'ESPANSIONE

MODULO IDRAULICO CON POMPA SEMPLICE PRESSIONE BASSA SENZA FANGO D'ESPANSIONE

MODULO IDRAULICO CON POMPA DOPPIA PRESSIONE BASSA SENZA FANGO D'ESPANSIONE

MODULO IDRAULICO CON POMPA SEMPLICE ALTA PRESSIONE SENZA FANGO D'ESPANSIONE

MODULO IDRAULICO CON POMPA DOPPIA ALTA PRESSIONE SENZA FANGO D'ESPANSIONE

MODULO IDRAULICO CON POMPA SEMPLICE ALTA PRESSIONE SENZA FANGO D'ESPANSIONE

MODULO IDRAULICO CON POMPA DOPPIA ALTA PRESSIONE SENZA FANGO D'ESPANSIONE

SCHEDA PER LON

AUTOBUS COMUNICAZIONE BACNET

CALDAIA

STAGE ELETTRICO

RILEVAZIONE PERDITE

SCHEMA SIMPLIFIE
SIMPLIFIED WIRING
VEREINFACHTES SCHEMA

SEMPLIFICATI COLLEGAMENTI
SIMPLIFICADO CABLEDO

LD/ILD 150R -> 600R



01/04/2022

5

00DCG000341500

C

ZUBEHÖR UND OPTIONS

FILTER CEM VERÄNDERUNG GESCHWINDIGKEIT KONDENSATORVENTILATOR
ERHOEHTE ECM-FILTRATION FUER PUMPE MIT VARIABLEM DREHZAHL
PUFFERSPEICHERMODUL
PUFFERSPEICHERMODUL MIT ELEC ZUSATZHEIZUNG 16KW
PUFFERSPEICHERMODUL MIT ELEC ZUSATZHEIZUNG 31KW
PUFFERSPEICHERMODUL MIT ELEC ZUSATZHEIZUNG 45KW
VERWALTUNG FREE COOLING

ACCESSORI ED OPZIONI

FILTRO CEM VARIAZIONE VELOCITA VENTILATORE CONDENSATORE
FILTRO CEM VARIAZIONE VELOCITA POMPA
MODULO SERBATOIO
MODULO SERBATOIO CON INTEGRAZIONE ELEC DA 16KW
MODULO SERBATOIO CON INTEGRAZIONE ELEC DA 31KW
MODULO SERBATOIO CON INTEGRAZIONE ELEC DA 45KW
VERWALTUNG FREE COOLING

LD/ILD 150R -> 600R

	01/04/2022	6
00DCG000341500		C

CONEXIONES DE CONTROL DEL CLIENTE

- 1 ON / OFF REMOTO
- 2 SELECCION NO DE CONSIGNA
- 3 LIMITACION DE CAPACIDAD 1
- 4 PEDIDO CALIENTE / FRIO A DISTANCIA
- 5 CONTROL CLIENTE / PRODUCCION DE AGUA
- 6 LIMITACION DE CAPACIDAD 2
- 7 ALARMA / ALERTA
- 8 EN FUNCIONAMIENTO
- 11 CALDERA
- 12 CALENTADOR
- 13 RESISTENCIA DE CALEFACCION 1
- 14 RESISTENCIA DE CALEFACCION 2
- 15 RESISTENCIA DE CALEFACCION 3
- 16 RESISTENCIA DE CALEFACCION 4
- 17 EXTERNAL PUMP COMMAND BY 0-10V SIGNAL

ACCESORIOS Y OPCIONES

UNIDAD DE TEMPERATURA MUY BAJA (SALMUERA)
VENTILADORES DEL CONDENSADOR CON PRESION DISPONIBLE ESPECIAL
OPCION BAJO NIVEL SONORO

DISPOSITIVO DE ARRANQUE A TENSION REDUCIDA

ARRANQUE EN INVIERNO

RESISTENZA EVAPORATORE

CALENTADOR DEL CIRCUITO DE AGUA DEL AVAPORADOR

CALENTADOR DEL CIRCUITO DE AGUA DEL AVAPORADOR

CALENTADOR

UNIDAD DUPLEX

MODULO HIDROLICO CON BOMBA SIMPLE ALTA PRESION SIN BARRO DE EXTENSION

MODULO HIDROLICO CON BOMBA DOBLE ALTA PRESION SIN BARRO DE EXTENSION

MODULO HIDROLICO CON BOMBA SIMPLE BAJA PRESION SIN BARRO DE EXTENSION

MODULO HIDROLICO CON BOMBA DOBLE BAJA PRESION SIN BARRO DE EXTENSION

MODULO HIDROLICO CON BOMBA SIMPLE ALTA PRESION SIN BARRO DE EXTENSION

MODULO HIDROLICO CON BOMBA DOBLE ALTA PRESION SIN BARRO DE EXTENSION

TARJETA LON

AUTOBUS COMUNICACION BACNET

CALDERA

PERIODO DE PRACTICAS ELECTRICO

DETECCION DE FUGAS

SCHEMA SIMPLIFIE
SIMPLIFIED WIRING
VEREINFACHTES SCHEMA

SEMPLIFICATI COLLEGAMENTI
SIMPLIFICADO CABLEDO

LD/ILD 150R -> 600R

	01/04/2022	7
00DCG000341500		C

ACCESORIOS Y OPCIONES

FILTRO CEM VARIACION VELOCIDAD VENTILADOR CONDENSADOR

FILTRO CEM VARIACION VELOCIDAD BOMBEA

MODULO DE TANQUE

MODULO TANQUE CON INTEGRATION ELEC DESDE 16KW

MODULO TANQUE CON INTEGRATION ELEC DESDE 31KW

MODULO TANQUE CON INTEGRATION ELEC DESDE 45KW

GESTION FREE COOLING

LD/ILD 150R -> 600R

	01/04/2022	8
00DCG000341500		C

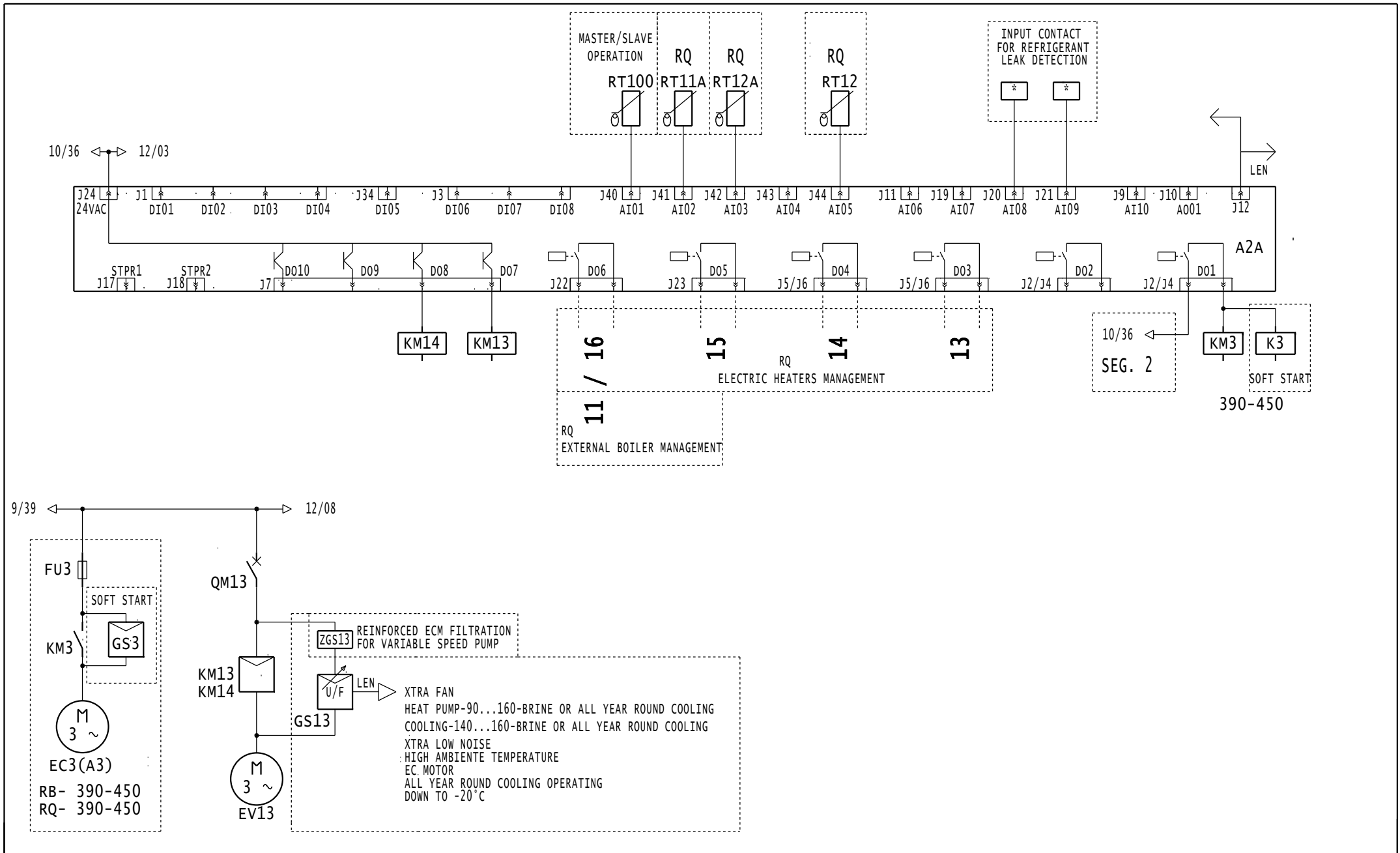

01	02	03	04	05	06	07	08	09	10	11	12	13	14	15	16	17	18	19	20	21	22	23	24	25	26	27	28	29	30	31	32	33	34	35	36	37	38	39	40	
SCHEMA SIMPLIFIE SIMPLIFIED WIRING VEREINFACHTES SCHEMA																	SEMPLIFICATI COLLEGAMENTI SIMPLIFICADO CABLEDO													LD/ILD 360R -> 450R							01/04/2022		11	
00DCG000341500																																			C					

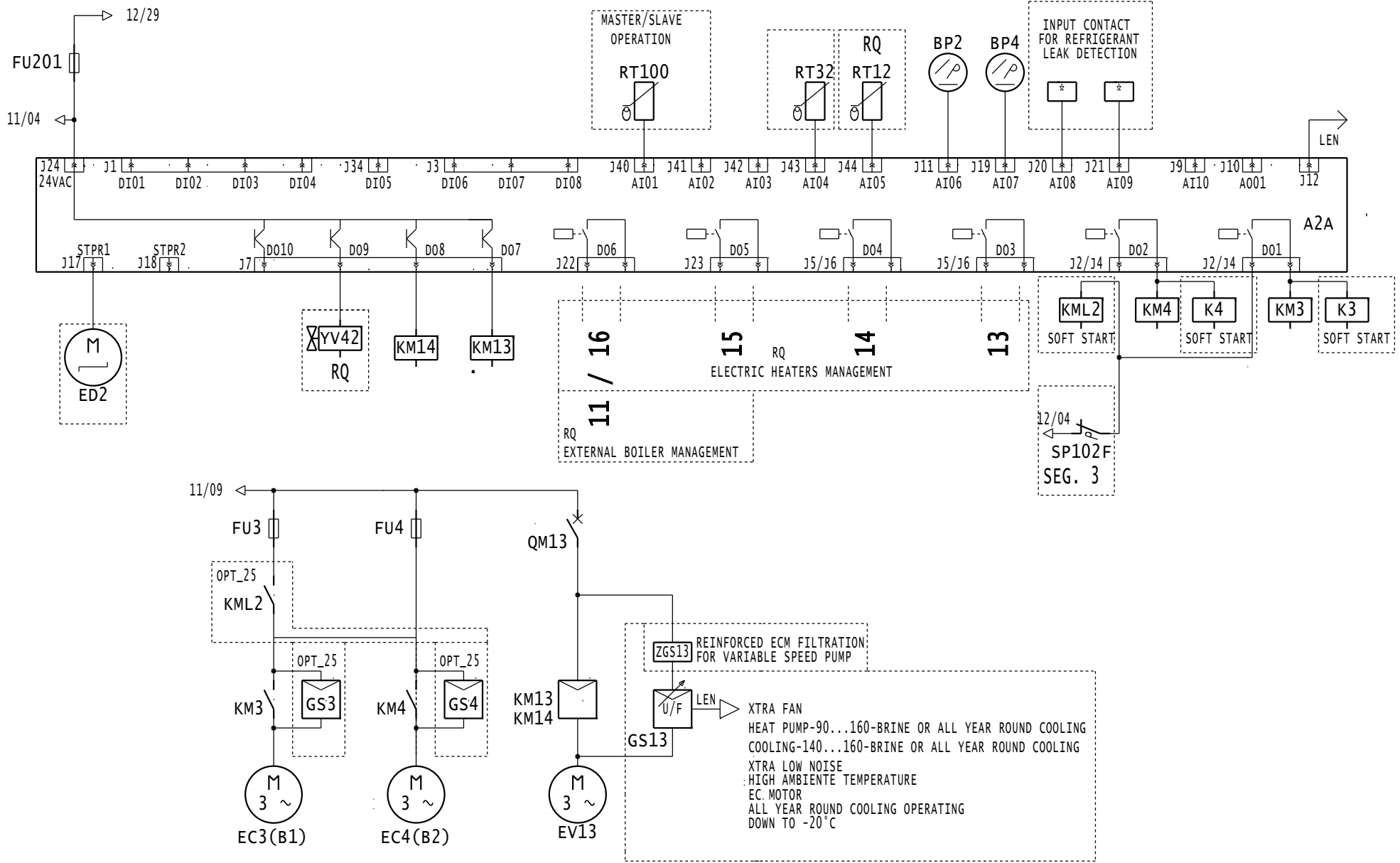

01	02	03	04	05	06	07	08	09	10	11	12	13	14	15	16	17	18	19	20	21	22	23	24	25	26	27	28	29	30	31	32	33	34	35	36	37	38	39	40		
SCHEMA SIMPLIFIE SIMPLIFIED WIRING VEREINFACHTES SCHEMA																SEMPLOCATI COLLEGAMENTI SIMPLICADO CABLEDO														LD/ILD 520R -> 600R								01/04/2022		12	
00DCG000341500																																		C							

